

CHAPTER 2 REACTOR AND MODERATOR SYSTEMS

0.0 INTRODUCTION

The simplified CANDU steam supply system consists of the reactor, moderator, heat transport and boilers:

- the calandria is a large, cylindrical vessel that contains the moderator at slightly above atmospheric pressure;
- the calandria is perforated by several hundred fuel channel assemblies, each of which consists of a calandria tube, a pressure tube and fuel bundles;
- the pressure tubes are part of the heavy water primary heat transport system that is under sufficiently high pressure (around 10 MPa) to limit the boiling of the coolant under normal operating conditions;
- the heat transport system continuously removes the heat generated in the fuel bundles and the pressure tubes (under normal operation via the boilers);
- the moderator cooling system removes the heat generated in the moderator and the calandria tubes.

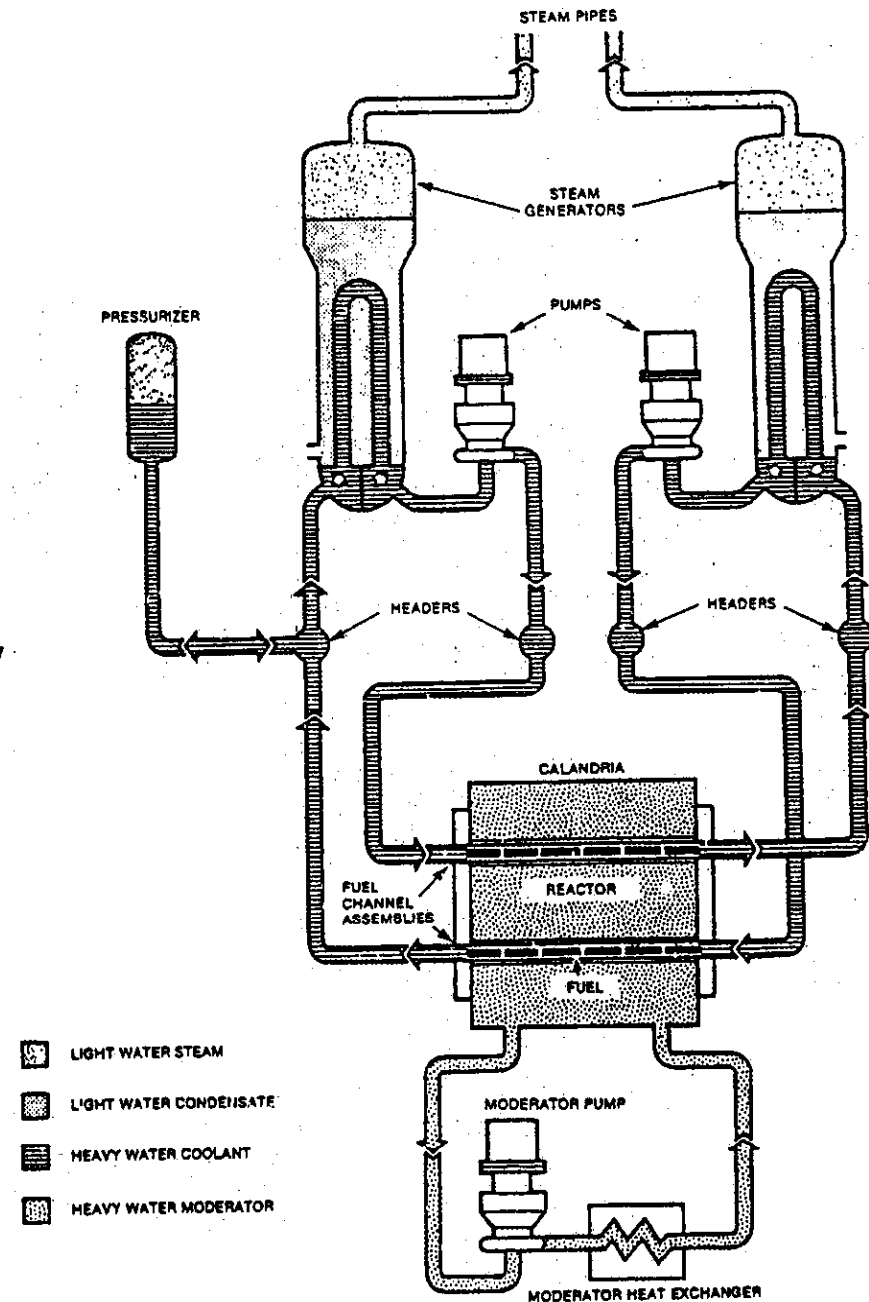

MODULE A: REACTOR STRUCTURES AND ASSEMBLIES

MODULE OBJECTIVES:

At the end of this module, you will be able to describe the following features of a CANDU reactor:

1. the physical arrangement and choice of calandria and pressure tube design;
2. the functions, structures, materials and physical properties of fuel channel;
3. the main characteristics of fuel and fuel bundle.

2.0 CANDU REACTOR ASSEMBLY

2.1 Functional Requirements:

- to support and locate the fuel channels and contain the moderator such that a controlled nuclear fission chain reaction will occur to produce heat;
- to provide for the removal of the heat generated by nuclear fission;
- to provide for the fuel to be replaced while the reactor is operating;
- to accommodate the specified temperatures, pressures, radiation fields and loads acting on the reactor during normal and abnormal operation, fabrication, transportation, storage, installation, and all design basis events including a design basis earthquake;
- to locate and support the specified reactivity measurement, control and shutdown devices;
- to provide radiation and thermal shielding to protect nearby equipment and permit access for maintenance;
- to provide for major components, except the calandria-shield tank assembly, to be easily replaced or refurbished, which may be required after more than 30 years, to obtain a plant design life of 60 years.

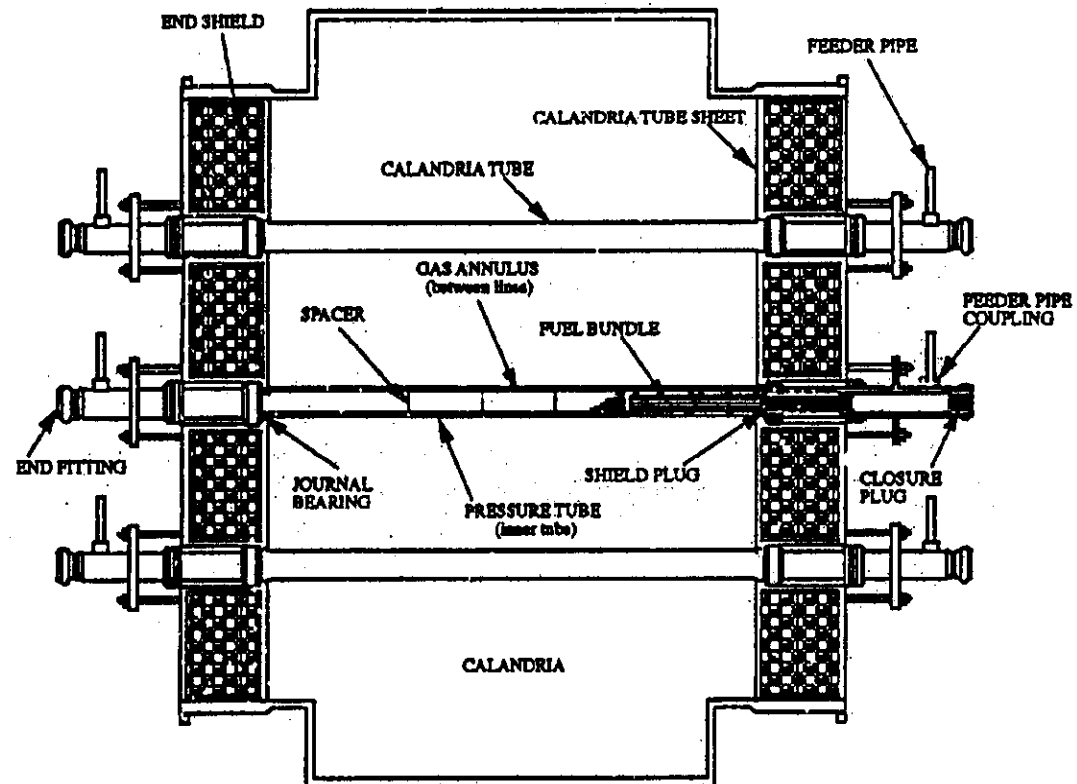

1.2 CANDU 9 Reactor Assembly

- reactor vault is approximately 20 m high, 20 m wide and 12.5 m deep
- reactivity mechanism deck holds all vertical flux measuring devices, vertical reactor control and safety devices
- horizontal reactivity control units (liquid poison injection) and flux measuring devices
- shield tank and end shields are filled with steel balls and light water: 13.3 m diameter and 8.1 m long
- calandria is 8.5 m diameter and 6 m long
- reactor core is 7 m diameter and 6 m long

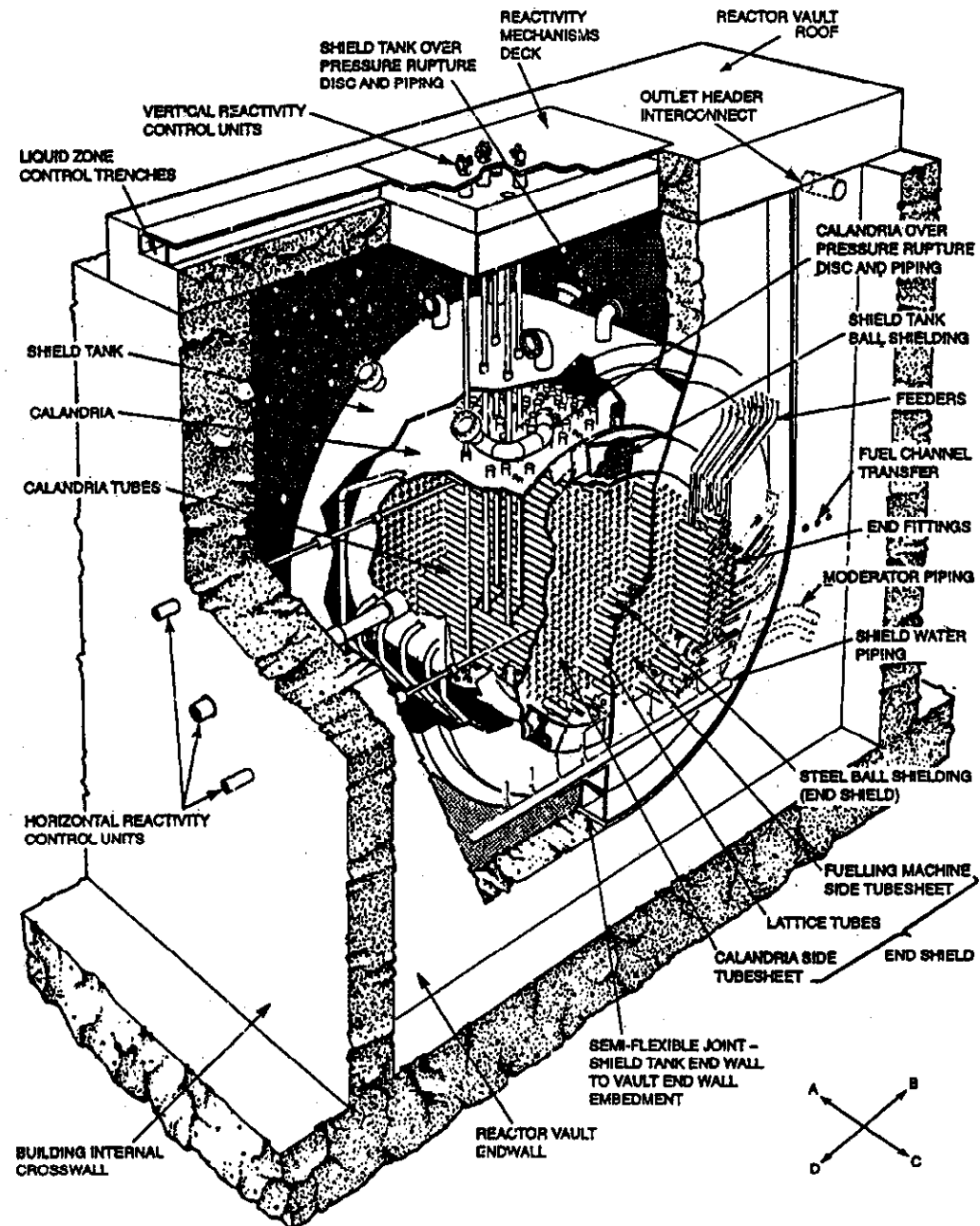

1.3 Fuel Channel Assemblies

- the main function is to provide a low neutron-absorbing pressure tube to support and locate the fuel within the reactor core, and to allow for a controlled flow of the high pressure heat transport coolant around and through the fuel;
- leaktight connections are provided to the heat transport inlet and outlet feeder pipes as well as to the channel closures at both ends;
- the fuel channel end fitting assemblies include a liner tube and shield plug at each end;
- a second tubular member, the calandria tube, forms a concentric container around the pressure tube;
- the annulus between the pressure tube and calandria tube is gas-filled, and provides thermal insulation to minimize heat loss from the high temperature heat transport system coolant to the cool moderator;
- overall length including end fittings is 12.4 m;
- pressure tube length is 6.35 m, inside diameter 103 mm, wall thickness 4.2 mm;
- calandria tube lattice pitch (square) 286 mm, length 5.9 m, inside diameter 129 mm, wall thickness 1.4 - 3.8 mm;
- fuel bundle diameter 102 mm.

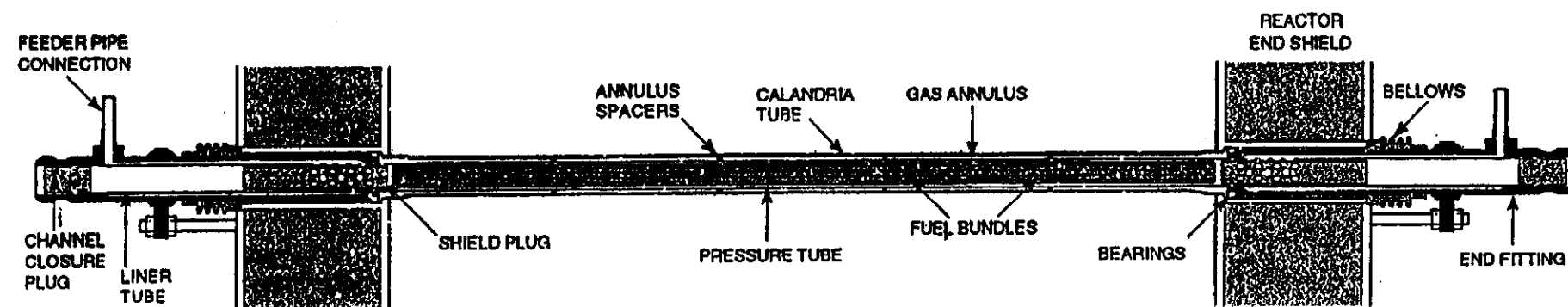

4 Arrangement of Fuel Elements, Pressure and Calandria Tubes.

- bundles of thin fuel elements allow fast neutrons to escape from the fuel;
- the relatively wide spacing of the fuel channels promote thermalization of neutrons
- the large surface area of the fuel bundle promotes heat removal from the fuel

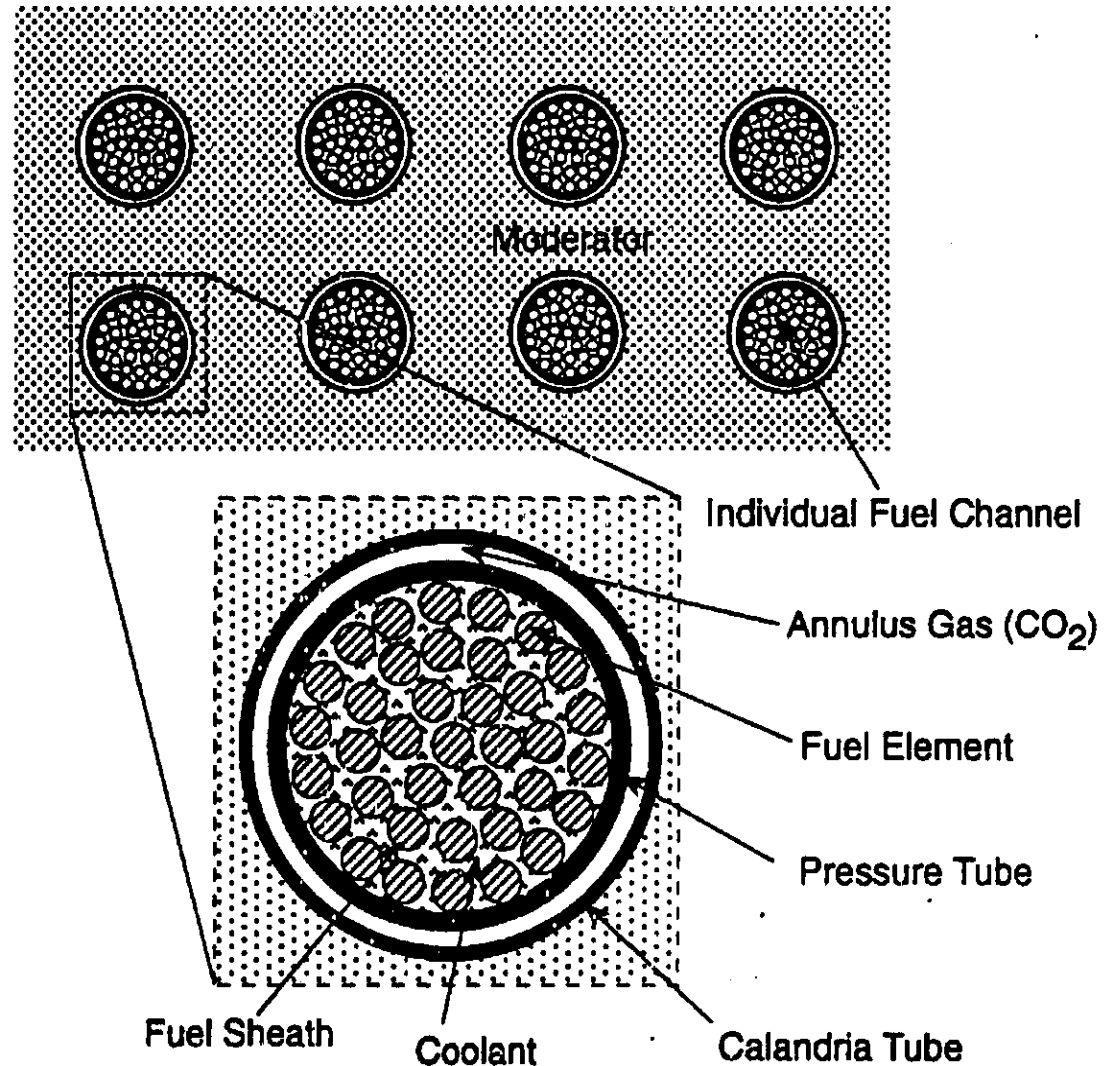

2.0 FUEL

The functional requirements for a CANDU fuel bundle are as follows:

- permit on-power refuelling;
- the fuel bundle shall maintain its structural integrity, leaktightness and dimensional stability during:
 - ⇒ transportation and storage before and after irradiation,
 - ⇒ reactor operation under normal operating conditions and power maneuvering,
 - ⇒ during refueling operations.
- the bundle shall have a specified hydraulic resistance to coolant flow, and:
 - ⇒ a uniform coolant flow distribution within the bundle,
 - ⇒ no local areas of flow stagnation adjacent to any element,
 - ⇒ sufficient margin-to-dryout under normal operating conditions;
- the bundle shall deliver its rated fission power at the specified operating conditions.

2.1 The Fuel Sheath must have the following characteristics:

- contain the uranium dioxide under normal operating conditions,
- minimize neutron absorption,
- minimize corrosion and hydrogen/deuterium pickup,
- minimize strain effects,
- minimize resistance to heat transfer,
- minimize hydraulic head loss,
- withstand normal operating (including refueling) loads

2.2 The uranium dioxide pellets are designed to:

- maximize the amount of fissile material in each fuel element,
- minimize volumetric changes during irradiation,
- control fission gas releases,
- be economic to produce.

2.3 Main features of the fuel bundle:

- CANDU 6 and CANDU 9 reactors use the 37-element fuel bundle design;
- the fuel sheath is made from Zircaloy-4:
 - ⇒ low neutron absorption,
 - ⇒ good corrosion resistance,
 - ⇒ low hydrogen pickup;
- the fuel pellets are made from uranium dioxide with 0.71% U235;
- a thin layer of graphite is applied on the inner surface of the sheath to reduce the effects of pellet-cladding interaction.
- a fully loaded fuel bundle weighs about 24 kg, of which more than 90% is uranium oxide fuel.

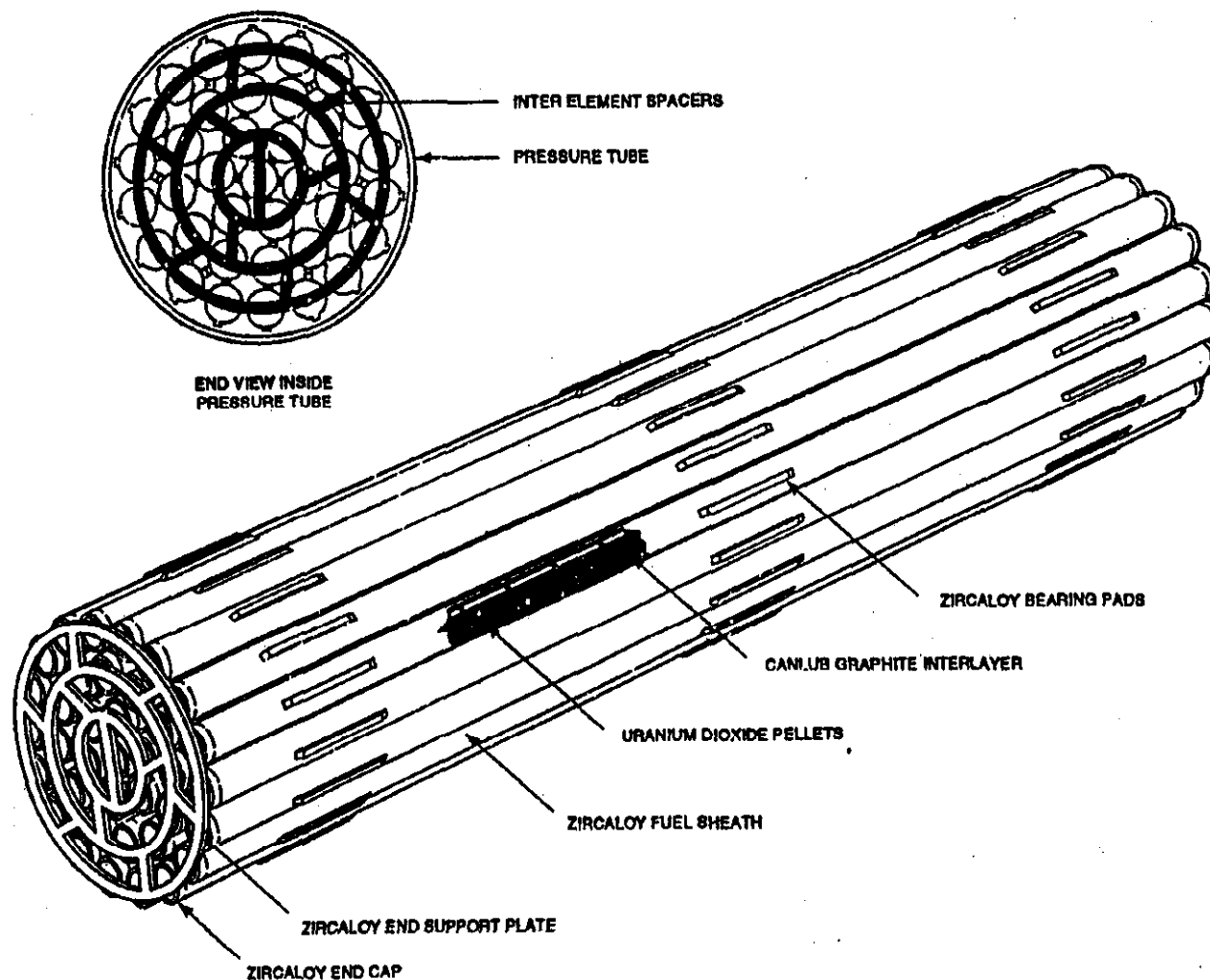

2.4 Fuel Channel Spacers (Garter Springs)

- must prevent direct contact between pressure tube and calandria tube:
 - ⇒ thermal insulation,
 - ⇒ hydrogen cracking,
- must not impede flow of annulus gas;
- four such spacers needed;
- cannot be fixed in place because of creep and thermal expansion;
- difficult to locate and adjust following installation.

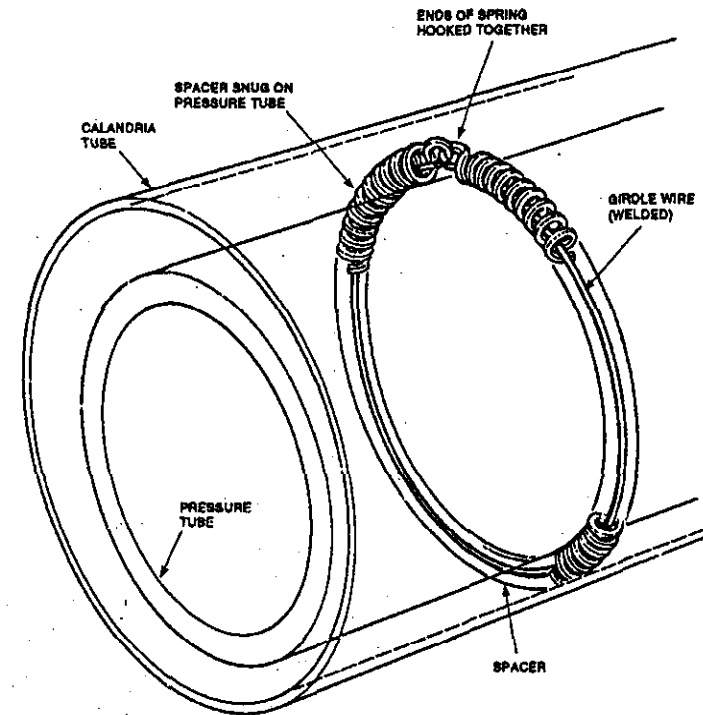



CHAPTER 2: REACTOR AND MODERATOR SYSTEMS

MODULE B: REACTIVITY CONTROL DEVICES

MODULE OBJECTIVES:

At the end of this module, you will be able to describe the following features of a CANDU reactor:

1. The main functions of reactivity control devices;
2. The devices used to control reactor power;
3. The need for automatic reactor control.

INTRODUCTION

There are several reasons for controlling the spatial flux distribution of a CANDU reactor, and for having flux detecting, controlling and shutdown devices in a spatially varied distribution:

- the physical dimensions of the core of a CANDU 9 reactor are large in relation to the average distance traveled by a neutron, hence local neutron flux disturbances could develop while bulk power is constant;
- an even flux distribution is necessary to achieve maximum extraction of energy ("burn-up") from each fuel bundle;
- preventing local flux peaks is essential to minimizing damage to the fuel;
- safety system independence is enhanced by locating devices for the different systems in different orientations.

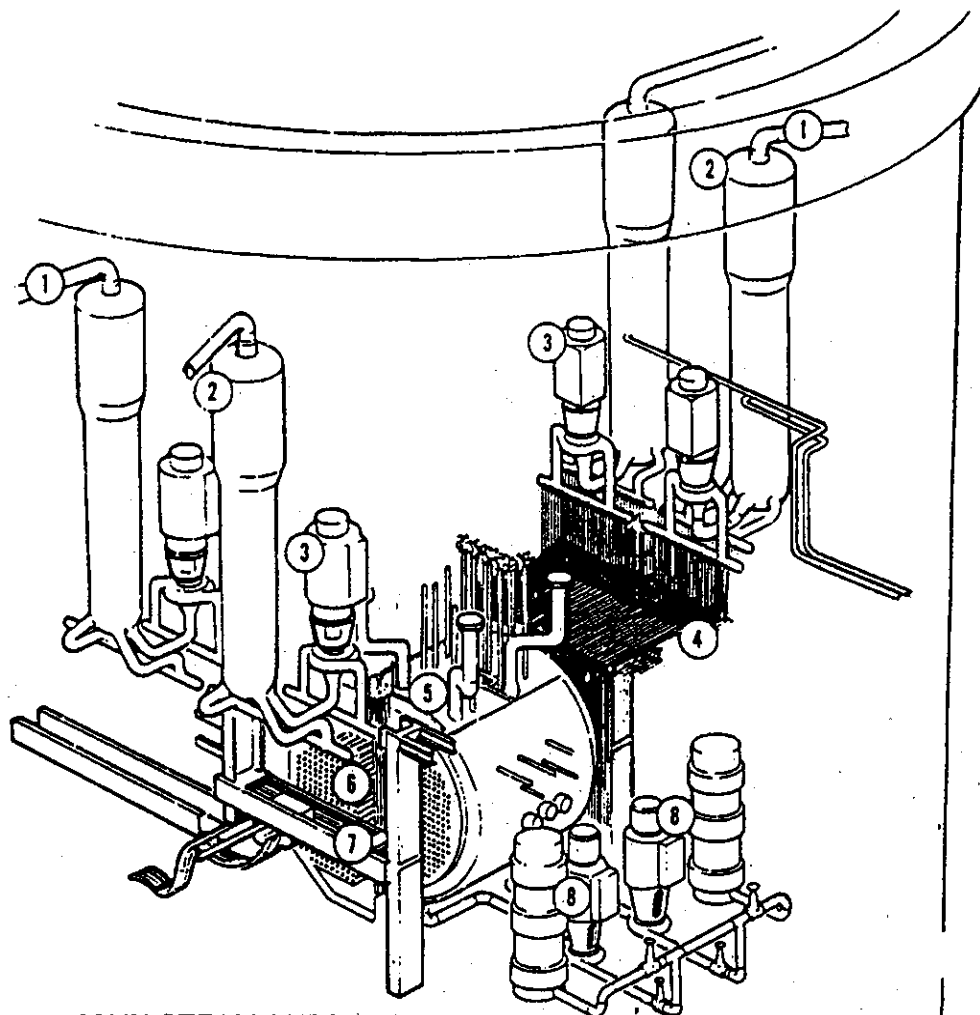

- 1 MAIN STEAM SUPPLY PIPING
- 2 STEAM GENERATORS
- 3 MAIN PRIMARY SYSTEM PUMPS
- 4 FEEDERS
- 5 CALANDRIA ASSEMBLY
- 6 FUEL HANNEL ASSEMBLY
- 7 FUELLING MACHINE BRIDGE
- 8 MODERATOR CIRCULATION SYSTEM

REACTIVITY CONTROL DEVICES

Reactivity control devices are provided to alter the rate of neutron multiplication (either as controllers or as shutdown devices). Control is provided for the following effects:

- long-term bulk reactivity, mainly controlled by on-power fuelling;
- small, frequent reactivity changes, both global and spatial-controlled by the liquid zone control system;
- additional positive reactivity for xenon override and fuelling machine unavailability, mainly resulting from the withdrawal of adjusters;
- additional negative reactivity for fast power reductions and to override the negative fuel temperature effect, provided by the insertion of mechanical control absorbers;
- initial excess reactivity and decay of xenon following a long shutdown, compensated by moderator poison.

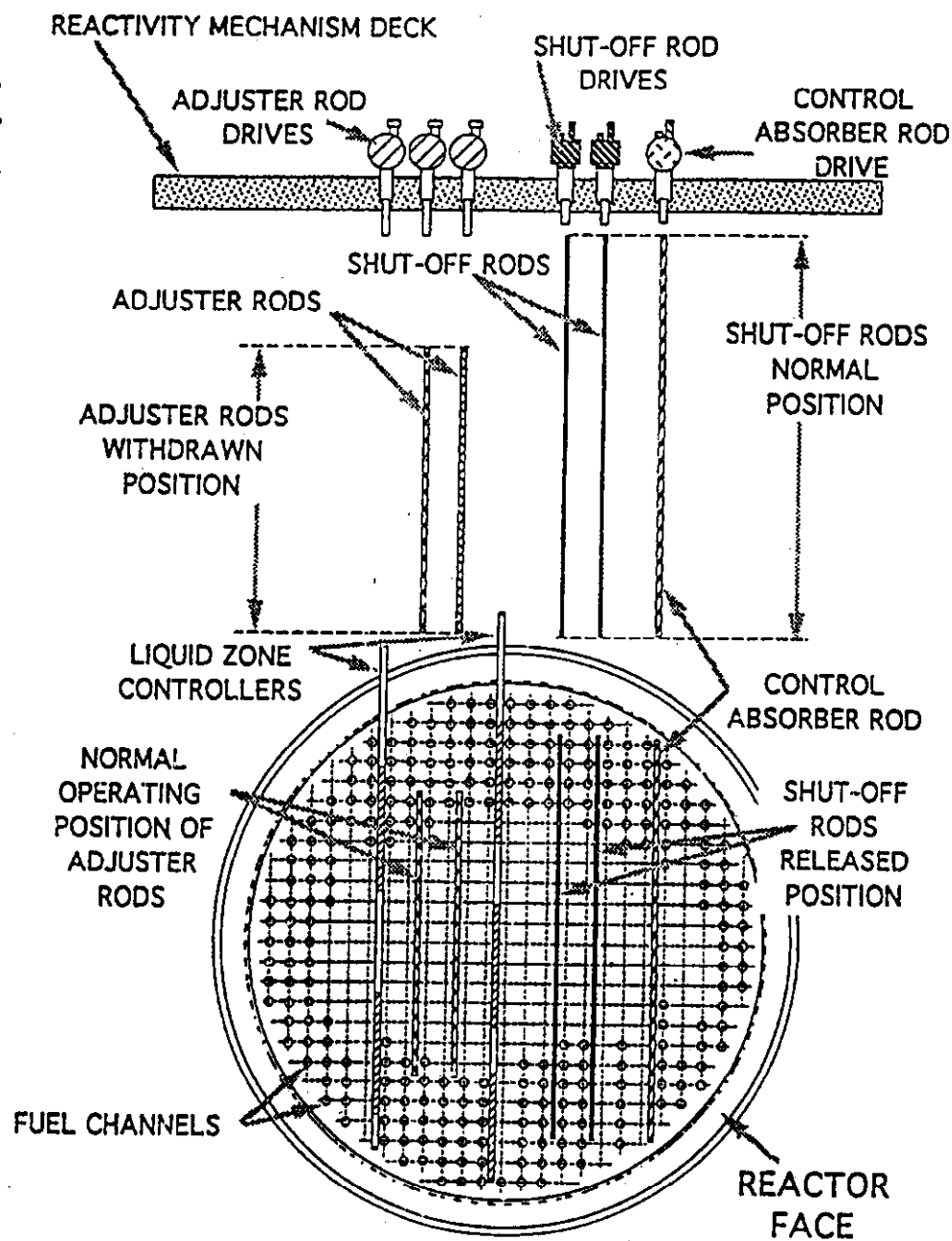

ADJUSTER RODS

The adjuster rods are provided to:

- shape the neutron flux for optimum reactor power and fuel burnup;
- supply positive reactivity beyond the normal control range of the zone controllers when required;
- compensate for the negative xenon reactivity up to 35 minutes after a shutdown from full power ("poison override").

There are 24 adjuster rods:

- the rods are made of stainless steel;
- they are arranged in three rows each containing eight rods;
- the rods are normally fully inserted in the core;
- the rods are moved in banks;
- the maximum total reactivity which may be gained on withdrawal of all adjuster rods is about 16 mk;
- the maximum reactivity change rate of any one bank of adjusters is ± 0.07 mk/s.
- the operation of the adjusters is normally controlled by the reactor regulating system, but can also be manually operated under prescribed conditions.

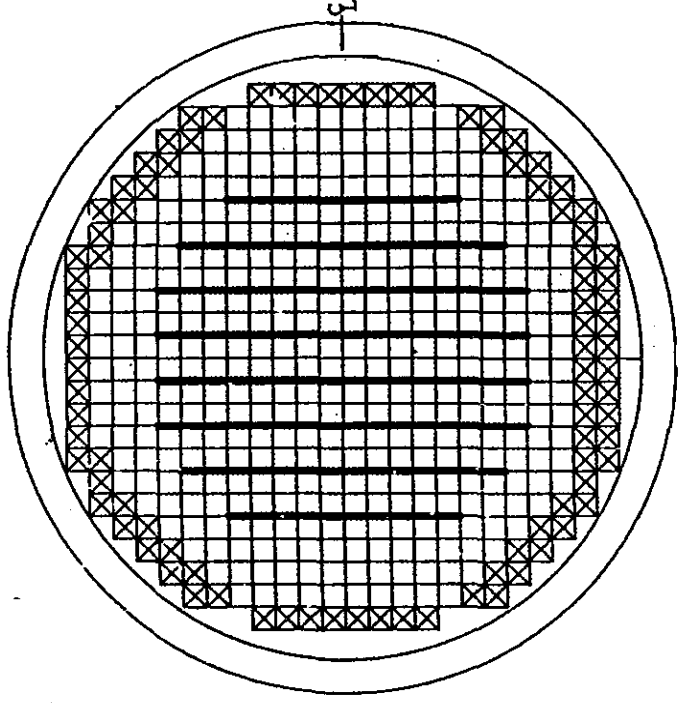
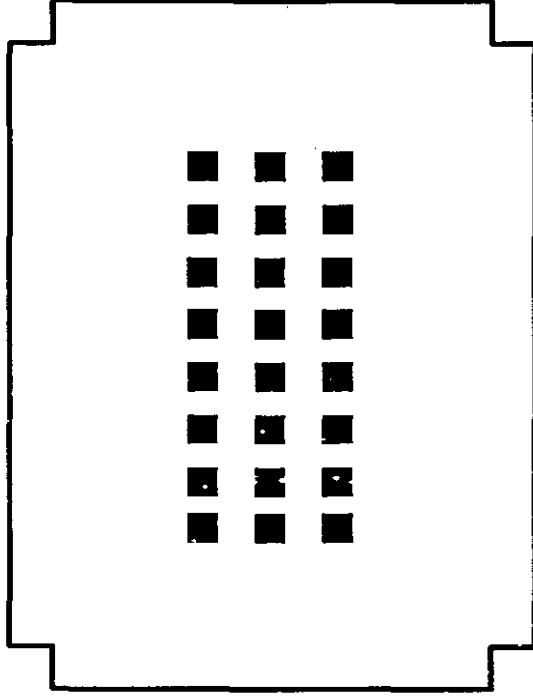

MECHANICAL CONTROL ABSORBERS

- the mechanical control absorber rods consist of tubes of cadmium sandwiched between stainless steel;
- there are four MCAs;
- they are normally poised out of the core;
- they are driven in by the reactor control system to supplement the negative reactivity of the liquid zone control units, or dropped to effect a fast reactor power reduction (stepback);
- they can be driven into or out of the reactor core in one of two banks, at variable speed;
- they can be dropped by releasing their clutches; when dropped, the elements are fully inserted in three seconds;
- by re-energizing the clutch while the elements are dropping, a partial insertion to any intermediate position can be achieved;
- the maximum total reactivity worth of the mechanical control absorbers is about 10 mk.

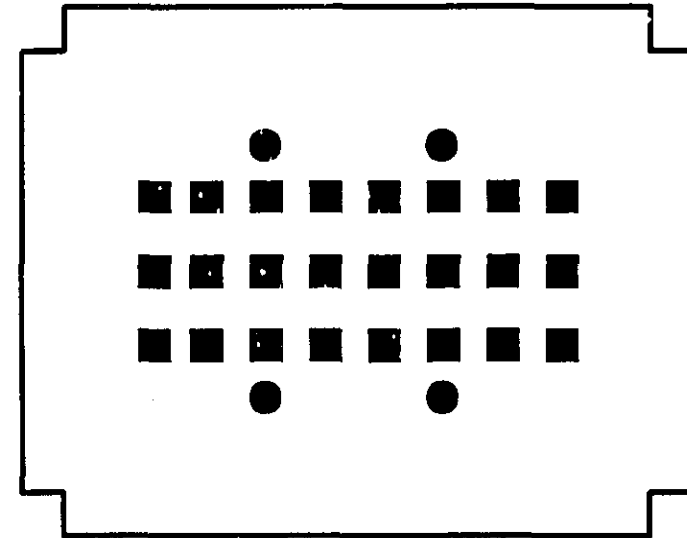

SHUTDOWN RODS

- 32 rods of cadmium and stainless steel;
- reactivity worth is -60 to -70 mk;
- spring assisted gravity drop, fully inserted in 2 seconds;
- normal withdrawal is controlled by the regulating system;
- the shutdown rods are withdrawn as soon as the trip signal has been cleared and the trip has been reset by the operator;
- all shutdown rods are withdrawn simultaneously;
- withdrawal of the shutdown rods is interrupted if:
 - ⇒ control is switched to manual, or
 - ⇒ the flux power error is excessive, or
 - ⇒ the reactor is tripped;
 - ⇒ if the log-rate exceeds 7 percent per second.

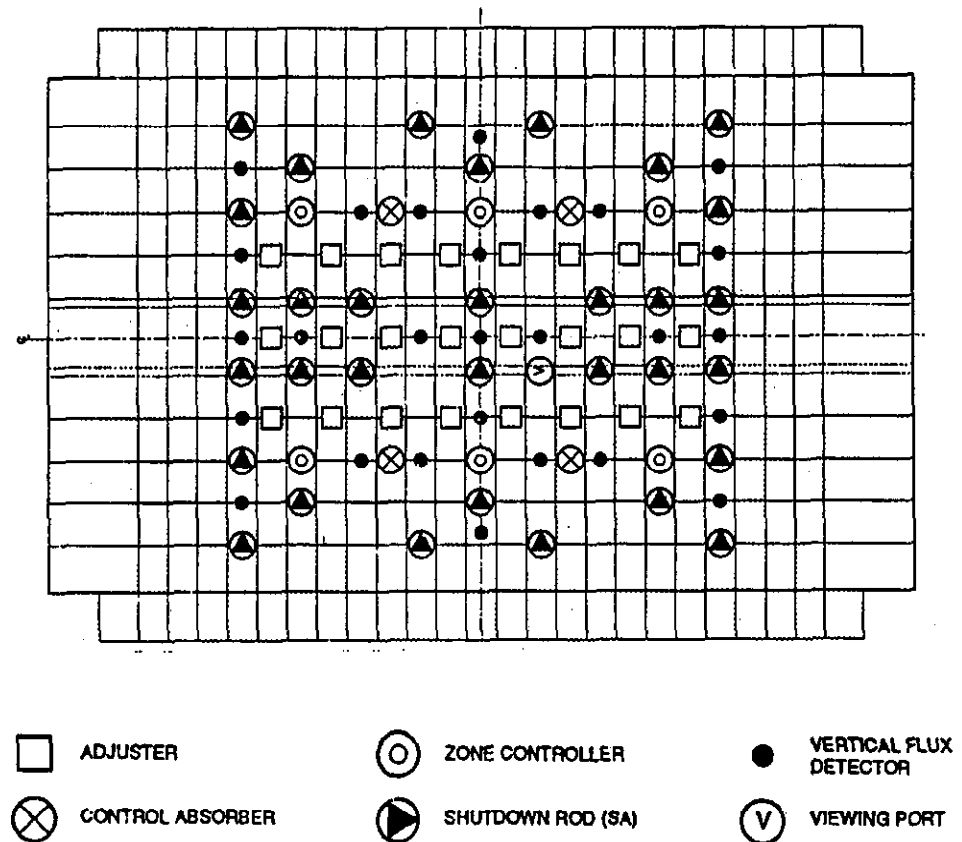

LIQUID ZONE CONTROL SYSTEM

The zone control system is designed to perform two main functions:

- to provide short term reactivity control to maintain reactor power at the demanded level during normal operation (i.e. operating control of reactivity).
- to control spatial power distribution by suppressing regional power transients associated with space dependent reactivity perturbations.

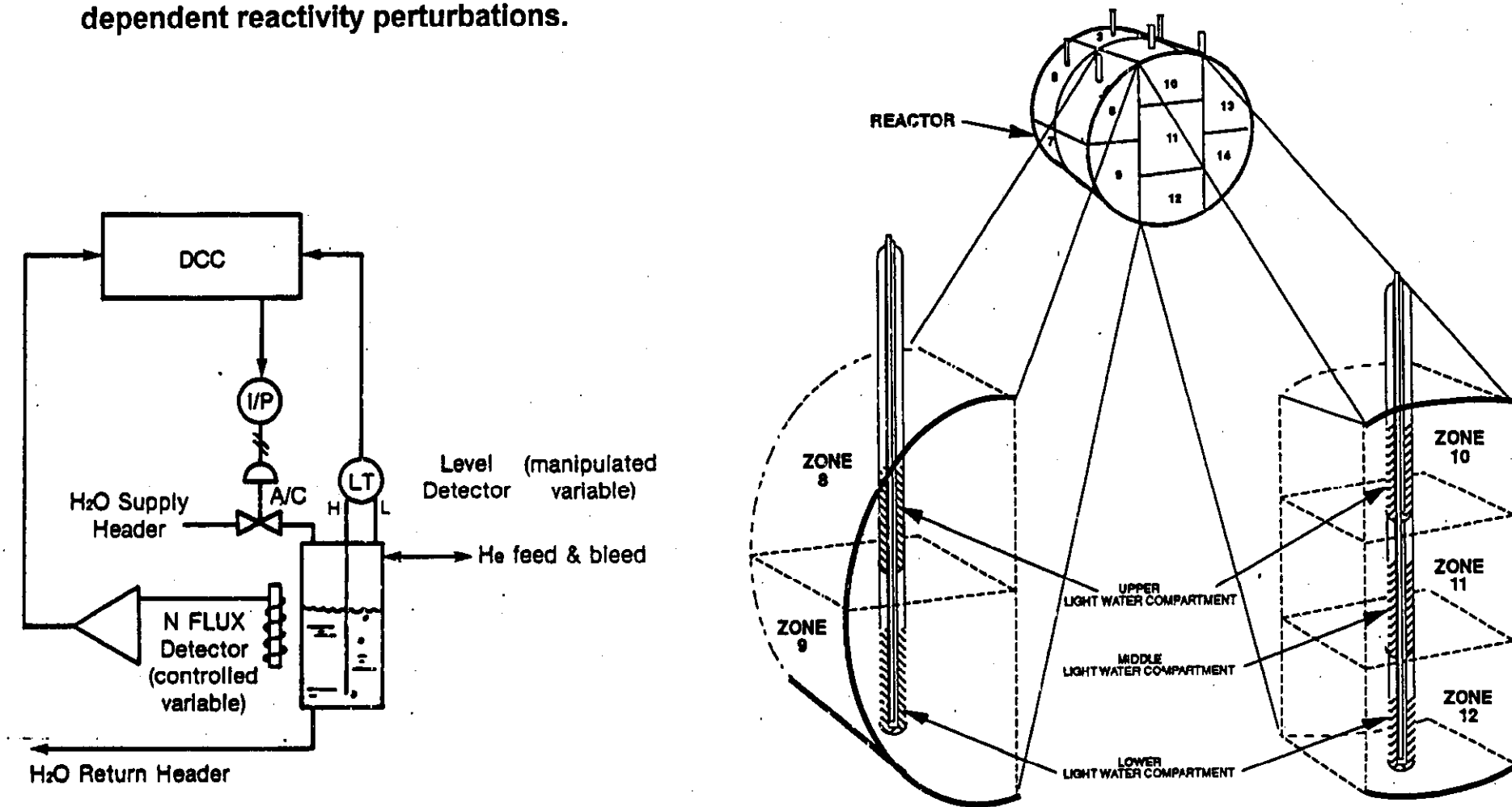

For the purpose of spatial control, the reactor is divided into zones. Spatial control is obtained by means of light water zone control assemblies and associated thermal neutron detectors in each zone.

- the zone control assemblies consist of compartmentalized vertical Zircaloy tubes which traverse the core;
- bulk reactivity control is achieved by varying the light water level in all compartments by the same proportion;
- spatial flux control is achieved by differential adjustment of the light water level in individual compartments.
- the reactivity worth of the liquid zone control system for the CANDU 9 equilibrium core is 7.2 mk from completely empty to full;
- in the nominal operating range of between 15% and 80% full, the total worth of the liquid zone control system is approximately 5 mk;
- between these limits the reactivity worth is essentially proportional to the average level; the corresponding reactivity coefficient is $-0.077 \text{ mk}/\%$ full.

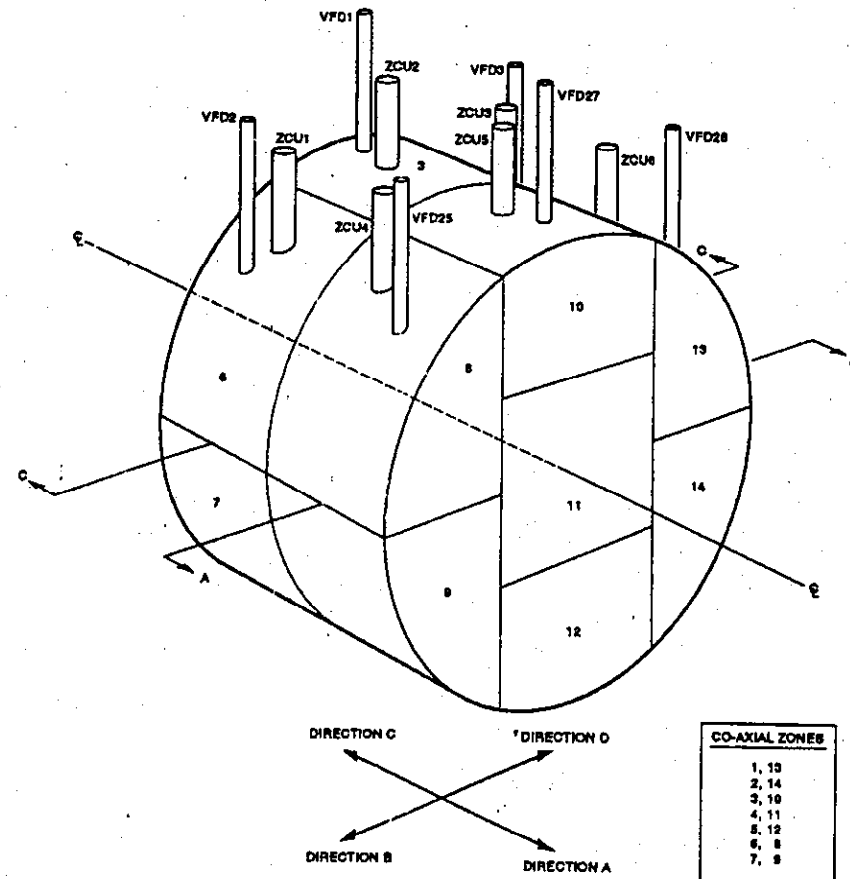

960243-2

MODERATOR POISON

- moderator poison is used to reduce excess reactivity to compensate for xenon decay
- during fresh fuel conditions Boron is used;
- during shutdown conditions Gadolinium is used;
- since the burnout rate of gadolinium on a subsequent startup is comparable to the xenon growth rate, a smooth control is possible when gadolinium is used for this purpose;
- note that this Gadolinium poison addition system is independent of the liquid poison injection system;
- the design rate of poison addition is equivalent to -0.75 mk/min;
- removal rates depend on poison concentration;
- at a poison level of -30 mk, the removal rate is approximately $+0.05$ mk/min.



CHAPTER 2: REACTOR AND MODERATOR SYSTEMS

MODULE C: MODERATOR SYSTEM

MODULE OBJECTIVES:

At the end of this module, you will be able to describe the following features of a CANDU reactor:

- 1. The functions and heat sources of the Main Moderator System;**
- 2. The equipment and operation of the Main Moderator System;**
- 3. The functions and operating characteristics of the Auxiliary Moderator Systems.**



INTRODUCTION

Heat in the moderator comes from the following processes:

- **heat production associated with the neutron moderation and gamma ray absorption processes;**
- **heat transfer from the pressure tubes across the annular gap to the calandria tubes;**
- **heat transfer from reactor structures due to nuclear heat generation and temperature differences.**

MAIN MODERATOR SYSTEM FUNCTIONS

- **Maintains a controlled bulk temperature in the calandria by providing sufficient heavy water cooling flow through the heat exchangers and ensures adequate net pump suction head for the pumps under all normal and upset reactor operating conditions.**
- **Maintains the moderator level in the calandria within the design operating level**
- **Serves as a heat sink with adequate circulation for heat removal following a loss-of-coolant accident coincident with loss of emergency core tooling, with or without Class IV power.**
- **Allows short term and long term reactivity control by providing a means for injection and removal of neutron absorbing chemicals.**
- **Maintains the chemical purity within specified limits by providing a means for diverting a stream through a purification loop.**

The main moderator system consists of:

- two interconnected circuits;
- each circuit contains a 50% pump and two 25% heat exchangers;
- isolation valves, piping and instrumentation;

During normal reactor operation both moderator cooling circuits provide circulation through the calandria.

During reactor shutdown, only one cooling circuit is required for moderator circulation.

Should moderator loss or leakage occur at a rate beyond the capability of the heavy water makeup system, the reserve water tank can be valved in to supply light water by gravity to the moderator thereby maintaining the moderator heat sink capability.

The moderator level in the calandria during warm-up and cooldown is accommodated by the head tank.

Relief valves, connected to the cover gas system provide overpressure protection to the moderator system and the calandria during normal plant operation.

Austenitic stainless steel is used for all moderator system heat components in contact with heavy water.

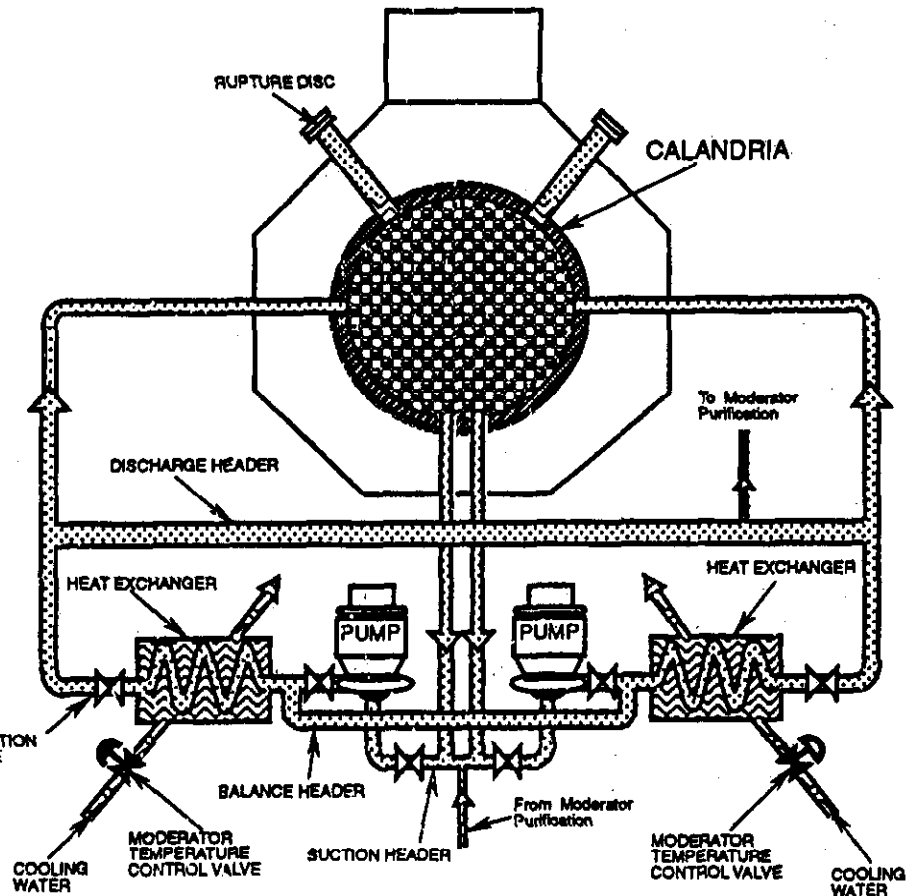

MODERATOR AUXILIARY SYSTEMS

Other integrated moderator auxiliary systems include the cover gas system for pressure and deuterium control, the moderator heavy water collection system, and the moderator sampling system.

Moderator Cover Gas System

- Provides an inert (helium) gas cover for the moderator to prevent corrosion and reduce radioactivity.
- Prevents explosive concentrations of deuterium gas from accumulating in the system.
- Provides pressure balance between the liquid injection shutdown system and the cover gas system, and between the reactivity control unit thimbles and the cover gas system.

The moderator cover gas system is a closed recirculating circuit comprising two compressors, two recombination units (each equipped with flame arrestors and heaters), a cooler, helium and oxygen bottle stations and associated valves, piping and instrumentation.

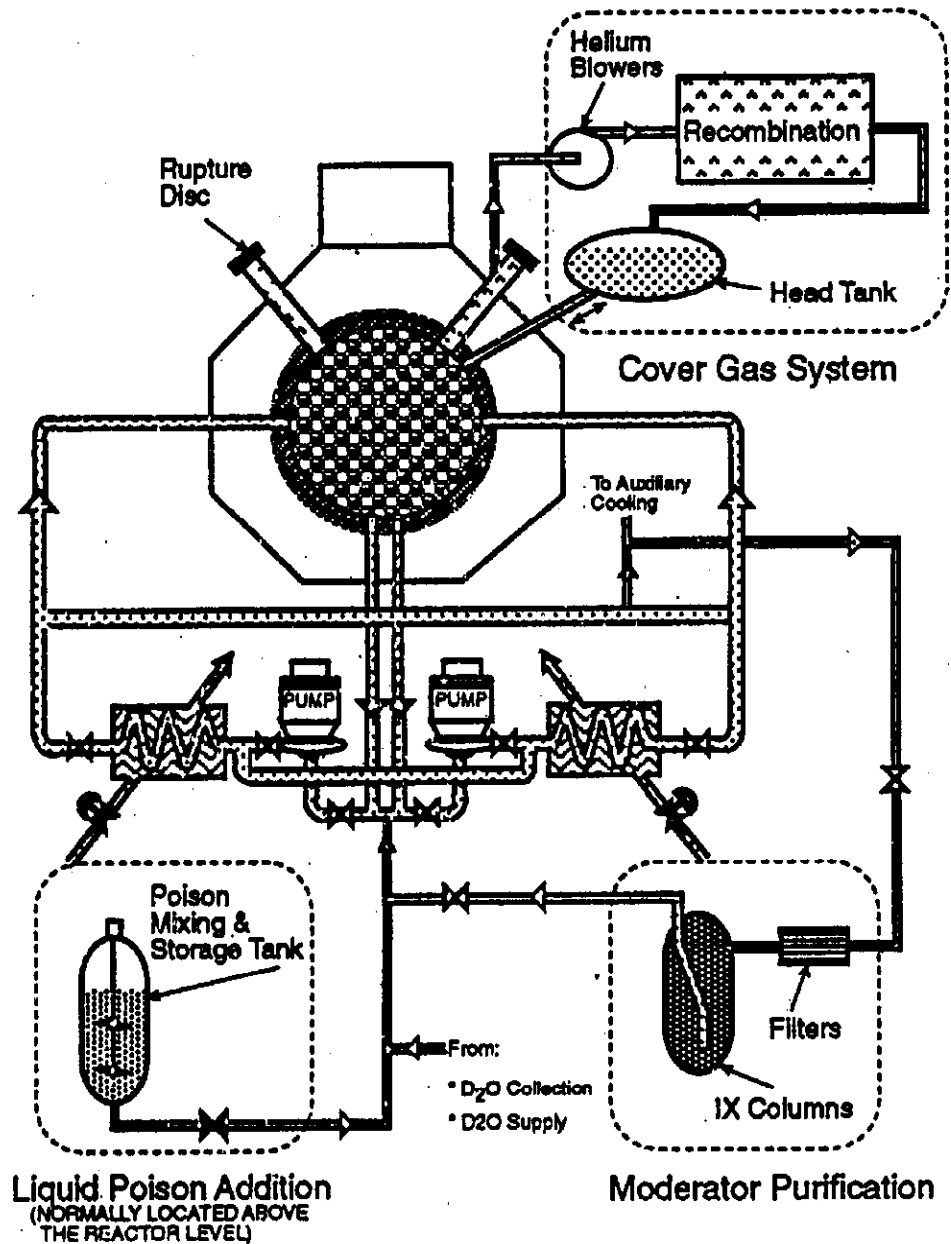

Moderator Liquid Poison System

- adds negative reactivity to compensate for excess reactivity in new fuel;
- adds negative reactivity to compensate for the reduction of the fission product Xenon-135 during a startup following a prolonged shutdown;
- provides a means for adding negative reactivity, to compensate for reactivity increase caused by non-normal refueling or adjuster operation;
- adds negative reactivity to compensate for the temporary reduction in Xenon-135 during startups and upward power maneuverings;
- adds sufficient negative reactivity to guarantee that the reactor cannot become critical during a major shutdown.

Boron, as boric anhydride, is used for long term reactivity control.

Gadolinium, as gadolinium nitrate, satisfies the short-term reactivity control requirements.

Moderator Purification System

- maintains the purity of the moderator heavy water to minimize radiolysis, thus preventing excessive production of deuterium and minimizing corrosion of components and crud activation;
- adjusts the concentration of the soluble neutron poisons (boric anhydride and/or gadolinium nitrate) in response to reactivity demands;
- removes the soluble poison, (gadolinium nitrate), after operation of the liquid injection shutdown system.