

# Chapter 12

## SHUTDOWN SYSTEMS: SDS1 AND SDS2

### 12.1 INTRODUCTION

Up to this point we have looked with great details at the reactor regulating system. In order to better understand the overall design of a CANDU type reactor, it is necessary to discuss the two shutdown systems.

Contrary to RRS, the shutdown systems are not “active”. Either they are fired, or they are not fired; and most of the time they are not fired...). The firing of the shutdown systems occurs when certain parameters exceed some pre-established setpoints determined by the designer, either during the design stage, or by ulterior analyses showing that changes are required.

The setpoints can be classified in two main categories. Some are fixed, and never change values. Other setpoint values will vary continuously, depending on the values of other parameters. These variable setpoints are called “conditioned parameters”. Generally, the fixed value parameters will act directly on system relays, whereas the conditioned parameters pass through an electronic device, the “Programmable Numerical Comparators”, CNP, before acting on the relays.

The mission of the emergency shutdown systems is to diminish rapidly the reactor power during abnormal conditions which could otherwise lead to undesirable states such as fuel failure, channel failure and the liberation of fission products. Thus the emergency shutdown systems are there to insure public safety in all circumstances.

Each CANDU reactor has two emergency shutdown systems, SDS1 and SDS2, completely independent of each other. They are also very different by design and by their intervention mode. There is no dependence of these systems on the actions of RRS. Each of the shutdown systems must be able, by itself, to stop the neutron chain reaction during any accident condition. A further requirement is that the safety analyses used to show this capacity must be performed with part of the system impaired. For SDS1, the two most effective rods, on a total of twenty eight, are assumed to stay out of core. For SDS2, the most effective injection line out of six is assumed dead.

## 12.2 TWO OF THREE LOGIC

In order to reduce the number of unnecessary firings, a two out of three logic is used by each of the shutdown systems. Each shutdown parameter is related to three measuring devices, and each of these devices is associated to one of three electrical chains of the shutdown system. When a reading passes its setpoint, a relay logic acts to open the electric circuit. This chain of the SDS is then said to be "opened". Two such chains of an SDS must be opened for the firing of the SDS.

Generally, the transmitter signals go through an amplifier. As long as the transmitter signal is below its setpoint, the amplifier emits a current sufficiently strong to maintain a relay in an excited state (closed state). When the setpoint is reached, this current is cut, and the relay cannot stay excited. It opens, and consequently opens the chain on which its contact is placed. There is no more current circulating on this chain. If another chain of the SDS eventually opens, the current maintaining the clutch of the shutoff rods would be cut, and the rods would fall in the core (SDS1). In the case of SDS2, it is the the valve system that would be opened forcing the liquid poison into the core. This relay logic is shown graphically on Figure 12.1.

Another advantage of the two out of three logic is to permit the verification, by frequent tests, of the availability of different parts of the system, from transmitters up to the last relays of the SDS chains. These tests are performed on one chain at a time, which permits to complete these verifications at regular prescribed intervals, without compromising the energy production, since two chains remain closed during these tests.

## 12.3 SDS1

SDS1 acts by inserting very rapidly twenty eight very absorbing shutoff rods. These are normally out of core, next to the reactivity device deck. They are kept out of core by a stainless steel cable, and compress a spring, which will assist the rods in their descent into the core. The cable is rolled on a pulley whose axis is blocked by a braking system consisting of an electro-magnetic clutch. An electric current is necessary to maintain these brakes on the pulley axis. If two chains of SDS1 open, this current does not circulate anymore, the brakes are opening, and the shutoff rods are propelled into the core. These brakes are normally opened, and the current is necessary to keep them closed: this is part of the fail safe design.

The three chains of SDS1 are the chains D,E and F. For each shutdown parameter, there is at least one transmitter on each of these chains. There are thus three readings for the instrumentation for each parameter. SDS1 checks eleven parameters, Those related to neutronics are:

- Log rate of ion chambers D,E and F : setpoint 10% /second
- High neutron power (ROP) : setpoint 122% FP

There are also parameters such as manual firing, high or low pressure of the primary coolant, high reactor building pressure...

## 12.4 SDS2

The mode of action of SDS2 is to rapidly insert in the reactor core, in the moderator, a large quantity of liquid poison, a solution of gadolinium nitrate, which is a strong absorber of thermal neutrons.

This liquid poison is a solution of Gadolinium nitrate and heavy water whose concentration is maintained at 8000 ppm. There are six tanks of liquid poison, three above reactor center, and three below center. Each tank is connected to a piping circuit, penetrating the core horizontally. These tubes are pierced by circular openings, permitting the liquid poison to flow into the moderator when injected. Each tank is kept at the moderator cover gas pressure of about 200 KPa. In these conditions, there is a natural boundary between the moderator and the liquid poison solution. This boundary is usually outside the core.

When there is firing of SDS2, the electrical current necessary to keep the valves of a high pressure Helium circuit is cut. The Helium, contained in a tank, is at a pressure greater than 8MPa. Once the valves opened, there is a great force applied on the liquid in the poison tanks. This liquid is then inject at very high speed in the core, and is propulsed in the moderator in the form of conical jets. A floating sphere in the liquid tanks follow the liquid level as it is reduced, and blocks the outgoing pipe when it reaches the bottom. The output of the tank will be stopped, preventing the entry of high pressure helium gas in the moderator.

The two out of three relay logic is also used for SDS2. Relays are kept in excited states until setpoints are reached. The SDS2 chains are G,H, and J. As for SDS1, there will be one transmitter per SDS2 chain. These transmitters are not the same as those of SDS1. SDS2 is completely independent of SDS1.

SDS2 keeps watch on 10 parameters, two of which are related to neutronics,

- Log rate of ion chambers G,H and J : setpoint of 15%/second
- High neutron power (ROP) : setpoint of 122% FP

Finally, it takes about twenty four hours to remove the liquid poison from the moderator, after that the condition that caused SDS2 firing has been cleared. This is done by a moderator purification circuit using ion exchange resins to separate the heavy water and gadolinium nitrate. This purification circuit is automatically closed when there is an emergency reactor shutdown.

## 12.5 ROP SYSTEM

The regional overpower,ROP, system groups the SDS1 and SDS2 high neutron power parameters.

SDS1 has thirty four Platinum flux detectors distributed in the core. Each detector is assigned to a chain, D,E or F, of SDS1. The setpoint, identical for each detector is fixed at 122% FP.

SDS2 has twenty three Platinum detectors, placed horizontally, in the core. Each of them is assigned to one of the chains, G, H or J, of SDS2. Of these, twenty two have a fixed setpoint of 122% FP, while the centrally located SDS2 detector has a setpoint of 128.3% FP.

The aim of the ROP system is to prevent fuel damage during postulated slow losses of regulation. In order to prevent center line fuel melting, the detector setpoints have been such that critical heat flux, related to departure from nucleate boiling, is not reached. The power at such a channel reaches critical heat flux is the critical channel power. It's exact value depends on both neutronic and thermal hydraulic conditions of each channel.

The detector setpoints are determined by postulating and analyzing a large number of perturbed states of the core (more than 700) with design codes. These perturbed states are obtained by displacing the various reactivity devices, individually and in combinations. A slow loss of regulation is then supposed to occur. The power is increased until a channel reaches critical power. The detector setpoints is then chosen such that there are no channels reaching critical power before ROP detection on two out of three channels.

An interesting aspect of ROP comes from the three daily calibrations of the detectors belonging to this system. A major part of this calibration is due to the local power variations induced by on-power refueling. The studies mentioned in the previous paragraphs are performed with time averaged nuclear properties for the fuel. These are much smoother than the instantaneous state of the core. In order to take the power ripple effects due to the refueling, calculations are performed frequently to determine the ratio between instantaneous channel powers and the time average channel powers. This ratio is called the Channel Power Peaking Factor, or the CCPF. The maximum of this ratio over all channels, the  $CPPF_{max}$  is retained and used to multiply, and thus increase, the individual ROP detector readings by means of the amplifiers. Generally speaking, the  $CPPF_{max}$  has a value of about 107% to 110% FP, which reduces the margin to the setpoints. There are also other correction factors to take into account, such as due to an increasing temperature at the inlet headers, produced by steam generator heat transfer degradation; this reduces the channel critical heat fluxes. The ROP margin is then reduced. The choice of channels to refuel then becomes a delicate matter if plant power is not to be reduced.

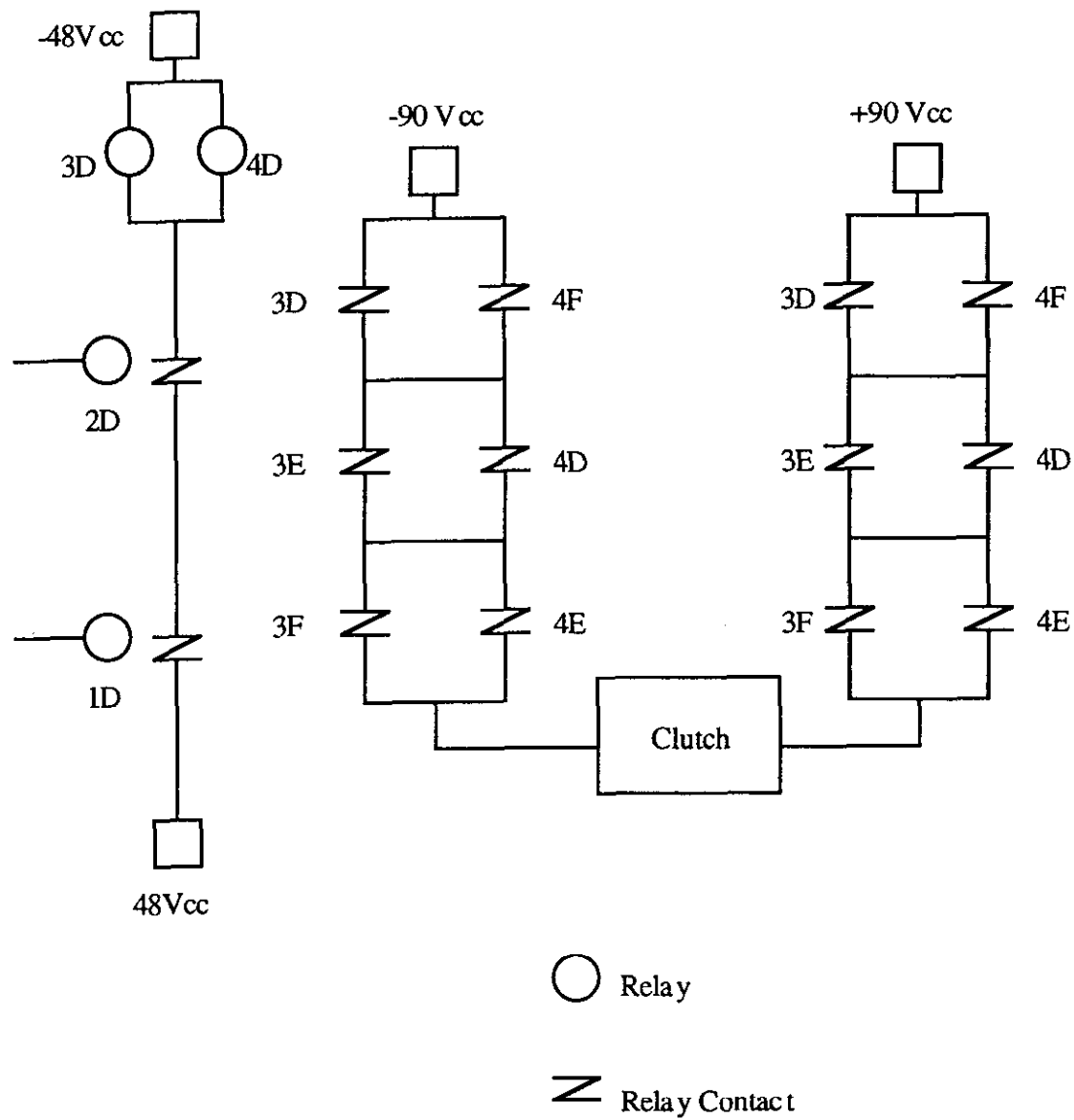

Figure 12.1: Simplified Example of two of three relay logic of SDS1