

## CHAPTER 2: HYDROGEN, RADIONUCLIDES AND SEVERE ACCIDENTS

### MODULE A: HYDROGEN

#### MODULE OBJECTIVES:

At the end of this module, you will be able to describe:

1. The origins of hydrogen released inside containment
2. The conditions for ignition and explosion
3. The effect on pressure inside containment
4. Hydrogen management techniques
5. TMI and numerical examples of hydrogen buildup
6. What is required for modelling hydrogen concentrations

## 1.0 ORIGINS OF HYDROGEN INSIDE CONTAINMENT

### 1.1 Radiolysis

- $2\text{H}_2\text{O} + \text{radiation} \rightarrow 2\text{H}_2 + \text{O}_2$
- Rate is about one  $\text{H}_2$  molecule generated per 100 eV radiation energy
- Rate increases by factor of 30 if boiling
- Always dissolved in main coolant loop, unless suppressed by adding 1 ppm  $\text{H}_2$  to coolant
- Builds up in gas space above RCS or moderator, also dissolved in liquid
- Concern for accident situations is slow, long-term buildup from sump water
- Negligible compared to danger from hydrogen-metal interaction

### 1.2 Zirconium

- Zirconium alloy (zircaloy) is used as a .5 mm protective coating (cladding) on fuel pellets
- Note: Advanced gas-cooled reactors have no metallic cladding, generate no hydrogen
- Reacts with water around 1000 C, reaction rate increases parabolically with temperature
- Exothermic reaction:  $2\text{H}_2\text{O} + \text{Zr} \rightarrow 2\text{H}_2 + \text{ZrO}_2 + 6500 \text{ kJ per kg of Zr}$
- Reaction not expected during a LOCA with normal ECC operation, except briefly during largest LOCA
- Occurs only during inadequate fuel cooling, even if reactor has been shutdown immediately after loss of coolant
- Generation is of limited duration, only first 15 minutes if no meltdown

### 1.3 Other considerations

- Interaction between the metallic component of corium (molten fuel + metallic debris) and water during severe accident with core meltdown
- Hydrogen used to cool generator is usually outside containment

## 2.0 REACTION OF HYDROGEN WITH OXYGEN

### 2.1 Nature of reaction: deflagration, detonation

- $2\text{H}_2 + \text{O}_2 \rightarrow 2\text{H}_2\text{O} + 1.3 \times 10^5 \text{ kJ per kg of hydrogen}$
- Deflagration (burning) : flame propagates slowly, uniform pressure throughout containment volume, relatively slow pressure increase
- Flame propagation rate depends on obstacles, turbulence/laminar flow conditions, inerting, vapour, droplets
- Deflagration-detonation transition (DDT) can occur at higher concentrations
- Detonation (explosion) : flame accelerates, possibly to supersonic speed, spatially non-uniform pressure pulses, destructive shock waves, challenge to containment structures
- Any electric motor or heated surface in containment can start the reaction. Multiple ignition sources may worsen detonation.

### 2.2 Critical concentrations

- At STP with vapour fraction < 10%, need 8%  $\text{H}_2$  for downward flame to propagate, 4% for upward flame, and 19% to detonate. (Fractions are by volume)
- At higher temperature with more steam, the oxygen concentration limits the reaction rate
- Need about 4% oxygen for deflagration, 9% to detonate
- Water spray droplets suppress ignition, reduce pressure and temperature rise during deflagration
- Combustion may be incomplete, may still be left with a few per cent uncombusted hydrogen
- N.B. Steam > 50% suppresses ignition, but steam condenses over a period of hours and days

### 2.3 Magnitude of pressure increase

- Deflagration in large vessel with 4-9%  $\text{H}_2$  and complete combustion leads to a factor 8 pressure increase, detonation with 19%  $\text{H}_2$  about factor of 17.
- Exceeds most design pressures

### **3.0 HYDROGEN MANAGEMENT TECHNIQUES**

#### **3.1 Inerting (inert gas in containment)**

- **Halon, nitrogen, CO<sub>2</sub> are possible inert gases**
- **Nitrogen is effective for preventing ignition, but displaces steam which is more effective than nitrogen**
- **Need about 20% Halon in the atmosphere, or enough nitrogen to reduce oxygen concentration <4%**
- **Pre-inerting (inerting the areas around the core before accident) is a problem for personnel, restricts maintenance activities, means more plant shutdowns**
- **May also inject inert gas when accident is detected (post-inerting)**
- **Injecting liquid gas is possible, but could lead to thermal shock**
- **Evaporating liquid CO<sub>2</sub> with heaters appears more practical**

#### **3.2 Natural and forced convection (mixing)**

- **Prevents buildup of high local concentrations anywhere in reactor building**
- **This is a only short term hydrogen management technique. Doesn't prevent increasing concentration.**
- **Natural convection requires removal of barriers between rooms, the barriers normally present before an accident. These panels should burst during an accident**
- **Gratings rather than solid floors permit buoyant flow to rise**
- **ACUs near highest point aid convection**
- **Evaporation from hot water in sump aids convections**
- **Forced convection by fans and ducts also effective**
- **CANDU 9 ventilation flowpath reconfigured during LOCA to maximize hydrogen mixing**

### 3.3 Igniters

- Igniters and recombiners are for long term control
- Diesel glow plugs, helical coil heated to 800C (AECL)
- Spark igniters (Siemens)
- Not a passive component!
- Requires power (battery or very reliable power supply) + initiating signal
- Igniters are activated by buttonup signal, may also be made self-activating
- Located where hydrogen likely to be generated, or where mixing can't be ensured
- Can start to remove hydrogen at low concentration (4% for Siemens design)
- Less effective at high steam concentrations
- Need about 50-150 per unit if used alone

### 3.4 Catalytic recombiners

- Known as passive autolytic recombiners (PARs)
- Platinum or palladium catalyst, possibly with a water-repellent coating, on plates in a box with a chimney
- Passive component, activated by hydrogen concentration
- Activate at hydrogen concentration < igniters starting point < deflagration limit
- Exothermic reaction aids convective flow of gas mixture through the recombiner
- Effective at higher steam concentration, complementary to igniters
- Designs available by Siemens, AECL, NIS
- Best design uses both igniters and recombiners

## 4.0 HYDROGEN CALCULATIONS

### 4.1 Safety analysis

- The thermalhydraulic safety analysis code for the RCS calculates fuel temperature, water temperature, reaction rate, and rate of hydrogen flow from the break
- Not sufficient to calculate average hydrogen concentration in large containment volumes, must confirm no high local concentrations can occur
- Adequate modelling of hydrogen distribution within containment requires 3-D fluid flow code, e.g. GOTHIC

### 4.2 Numerical examples: predictions of energy release

- Safety analysis for a CANDU-9 predicts about 2 kg hydrogen released during a very large LOCA with normal ECC operation, < 300 kg if ECC fails
- Older estimates for a BWR: 40,000 kg Zr  $\rightarrow$   $250 \times 10^3$  kJ (H<sub>2</sub> production)  $\rightarrow$   $210 \times 10^3$  kJ (H<sub>2</sub> burning). This assumes all the cladding reacts.
- Older estimates for a PWR: 20,000 kg Zr  $\rightarrow$   $140 \times 10^3$  kJ (H<sub>2</sub> production)  $\rightarrow$   $120 \times 10^3$  kJ (H<sub>2</sub> burning). This assumes all the cladding reacts.
- Nowadays, conservatively assume ~40% of Zr burns, get about .044 kg H<sub>2</sub> per kg Zr

### 4.3 Numerical example: Three Mile Island, 1979

- 10 hours after the turbine trip, a brief 200 kPa pressure spike indicated an explosion occurred
- Infer about 1/3 of the zirconium was oxidized
- Pressure spike  $\ll$  design pressure, containment never threatened
- Initiated rethinking of containment design for severe accidents and research into hydrogen explosions
- Negligible environmental consequences despite meltdown confirms successful containment design

R. Heck et al. | Nuclear Engineering and Design 157 (1995) 311-319

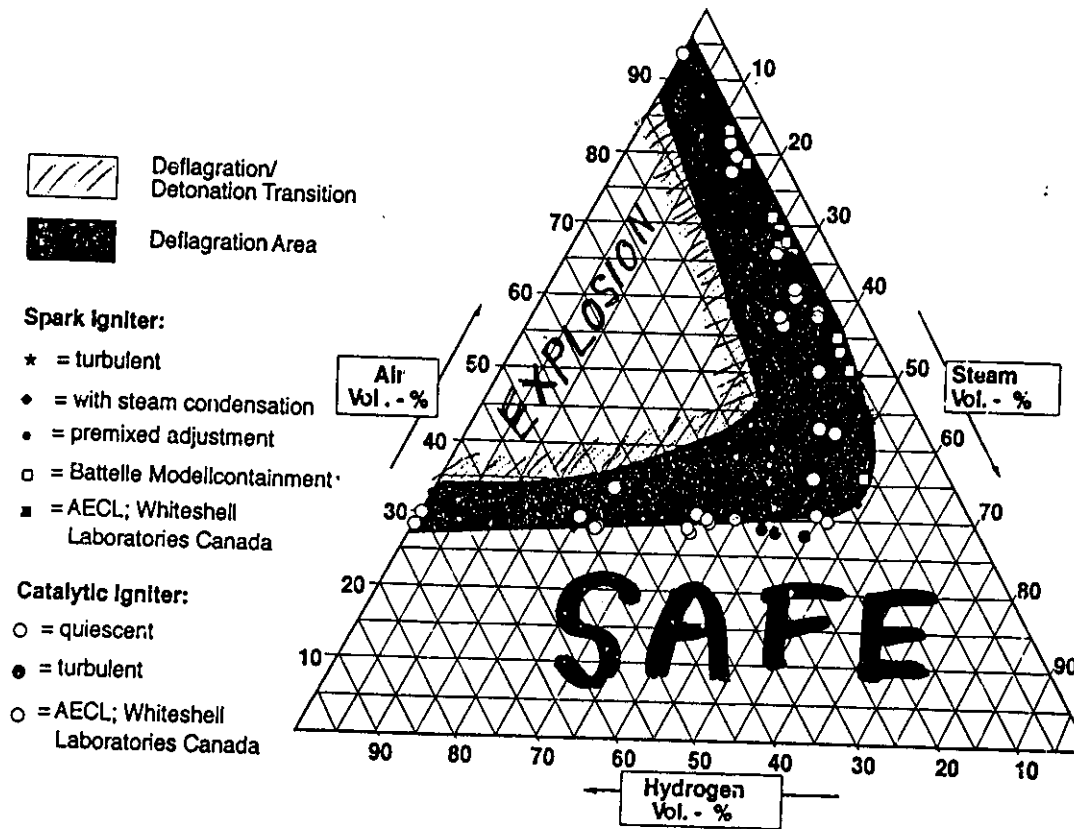

Ignition tests performed with Siemens igniters.

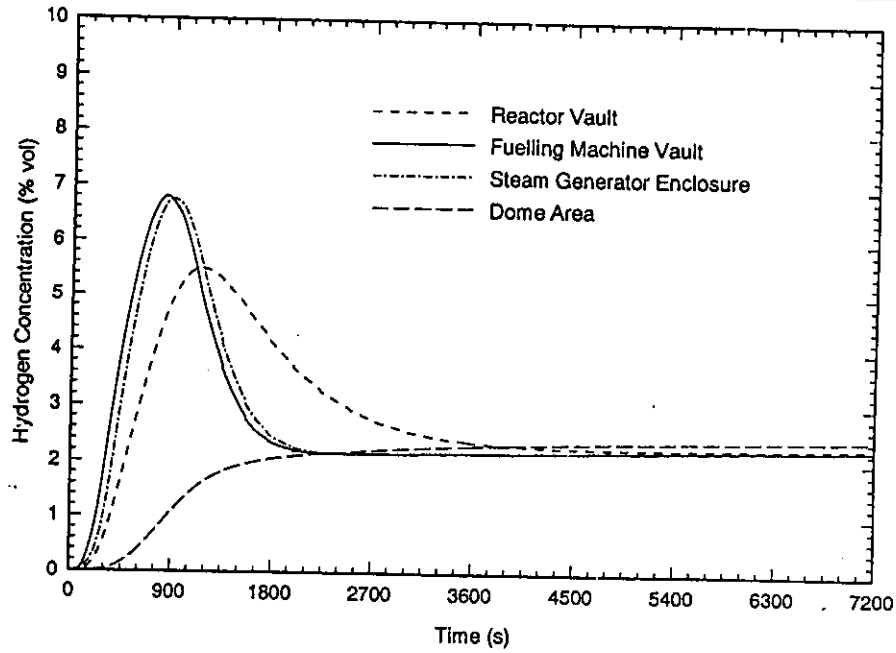

Figure 8. Preliminary estimates of hydrogen concentration in key rooms.

CANDU-9

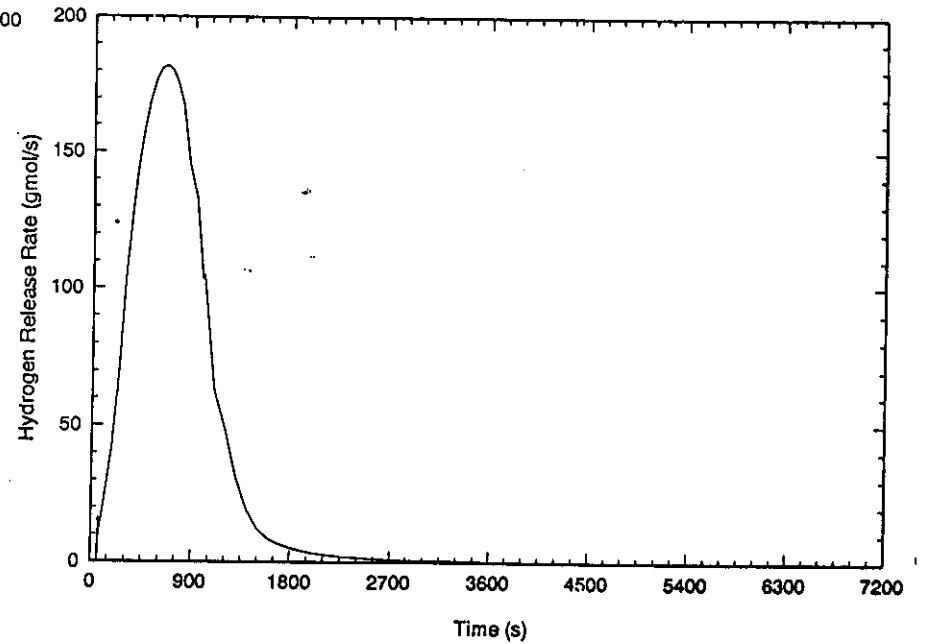
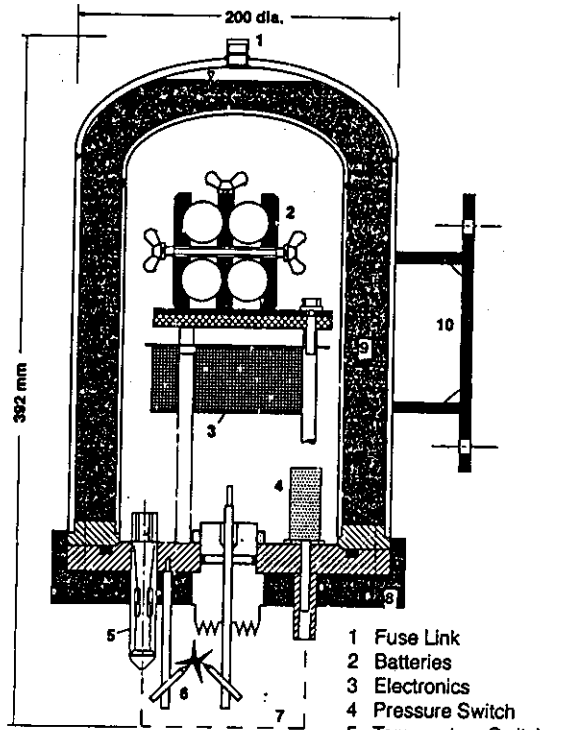

Figure 7. Preliminary estimate of hydrogen production rate following a LOCA with loss of emergency core cooling.





(Siemens)

- 1 Fuse Link
- 2 Batteries
- 3 Electronics
- 4 Pressure Switch
- 5 Temperature Switch
- 6 Electrodes
- 7 Contact Safety Device
- 8 Heat Insulation
- 9 Evaporative Cooling
- 10 Mounting

Spark igniter.

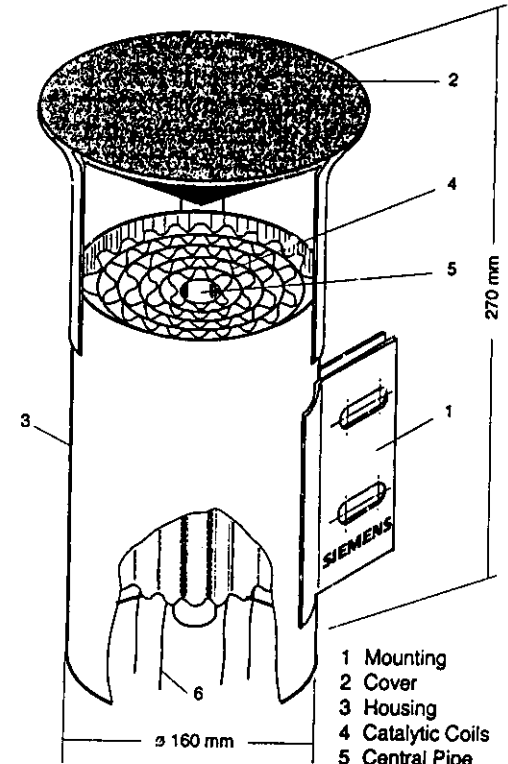

- 1 Mounting
- 2 Cover
- 3 Housing
- 4 Catalytic Coils
- 5 Central Pipe
- 6 Pt-ignition Wires

Catalytic igniter.

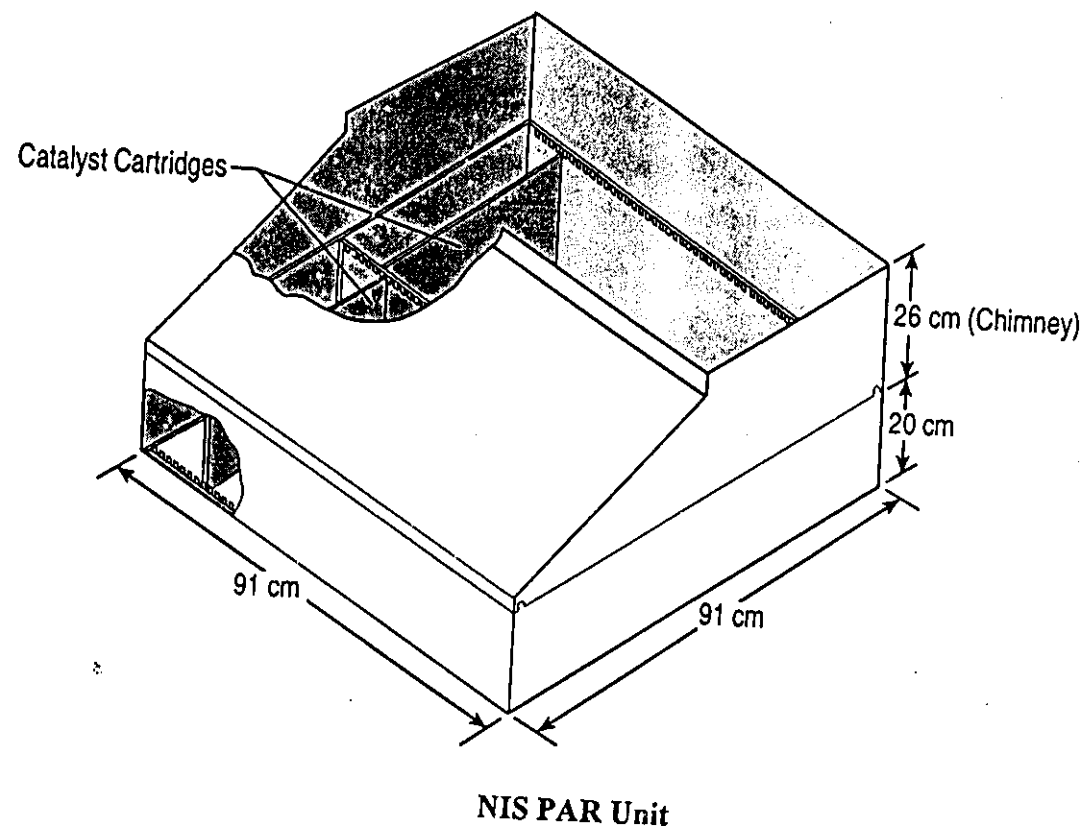



Catalytic recombiner.

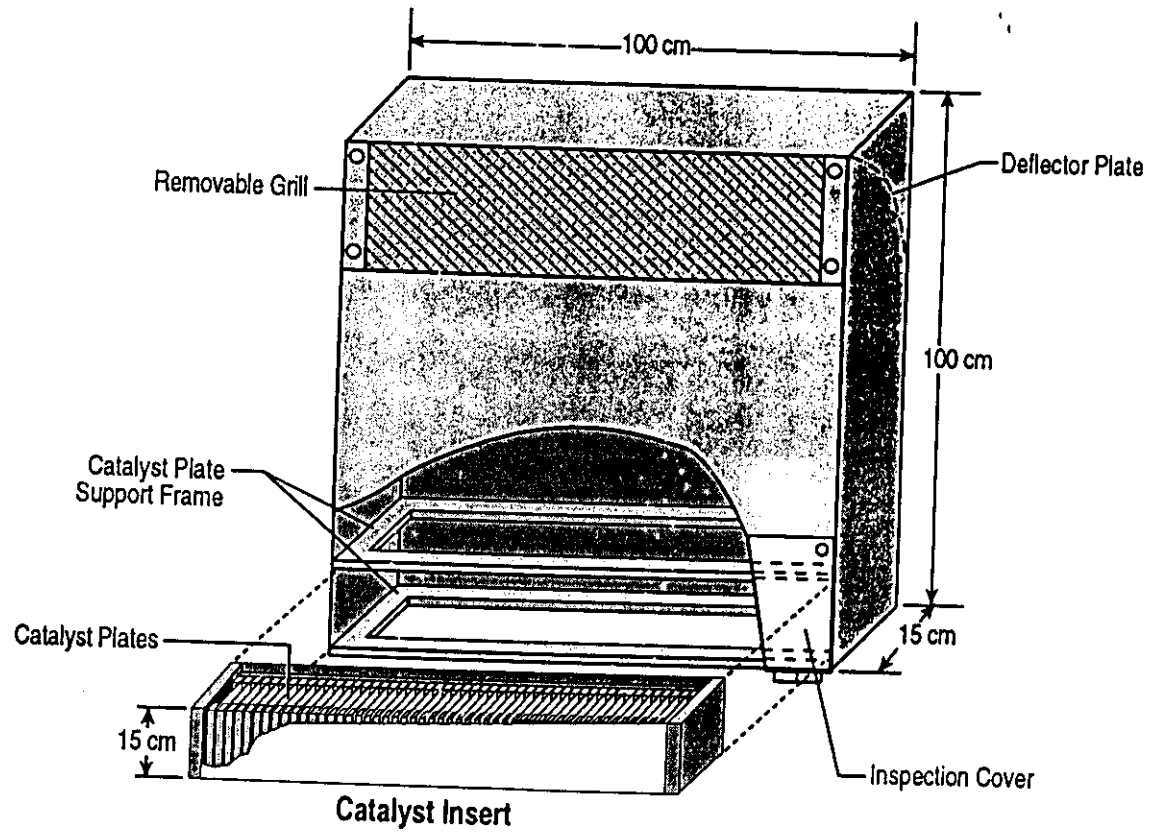

Siemens PAR Unit

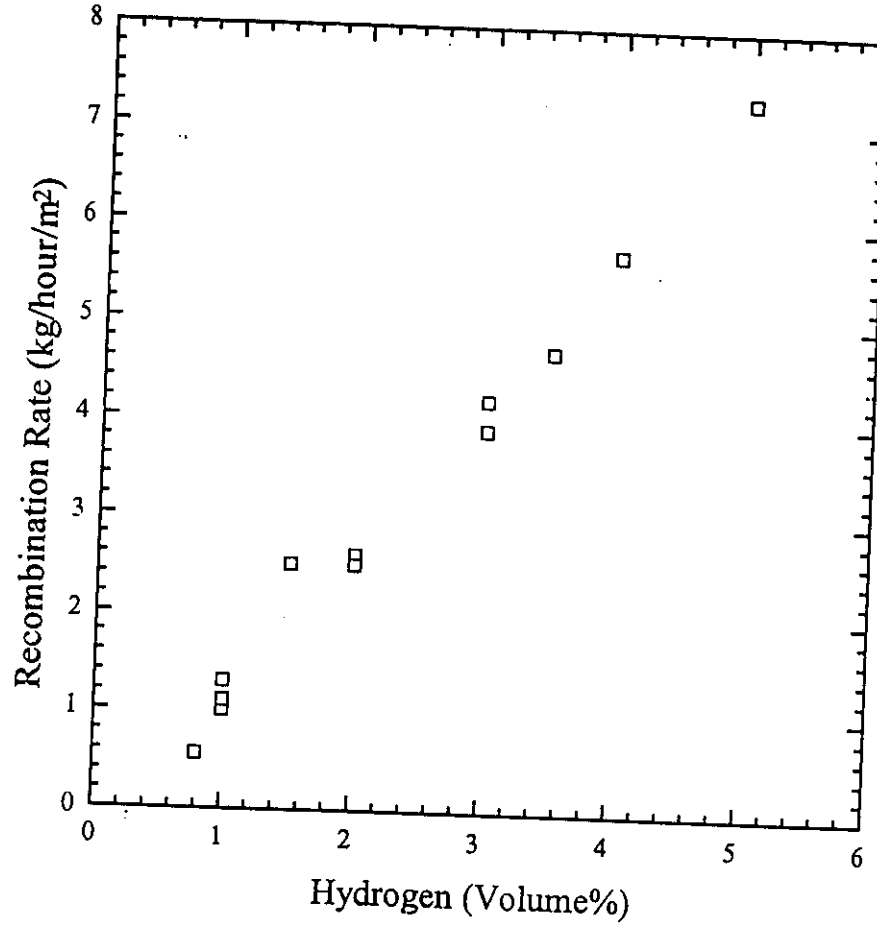

Figure 10. Recombiner Capacity for 0.2 m<sup>2</sup>  
Commercial Model Recombiner. (AECL)

R. Heck et al. / Nuclear Engineering and Design 157 (1995) 311-319

319

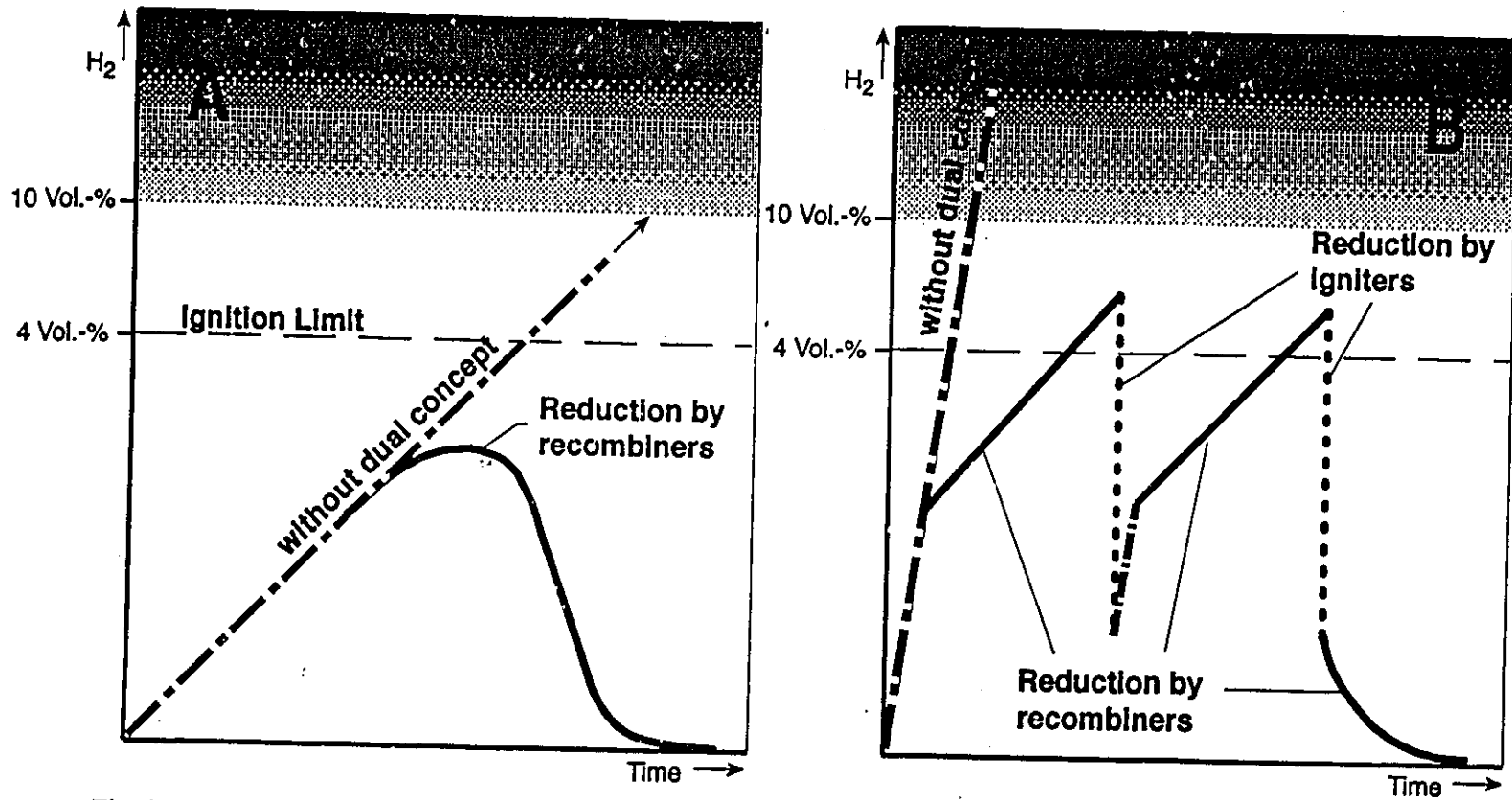

Fig. 2. Course of hydrogen concentration in severe accidents: A, low H<sub>2</sub> release rates; B, high H<sub>2</sub> release rates.

## CHAPTER 2: HYDROGEN, RADIONUCLIDES AND SEVERE ACCIDENTS

### MODULE B: RADIONUCLIDES

#### MODULE OBJECTIVES:

At the end of this module, you will be able to describe:

1. The nature and origins of fission products
2. The origin of radionuclides inside containment
3. The allowed dose to the public and the derived emission limit
4. Factors affecting dose absorbed by the public
5. The process by which fission products get into the coolant during an accident
6. Fission product behaviour inside containment
7. Fission product release paths

## 1. SOURCES OF RADIONUCLIDES

- The fuel is the major source, although there is always some radioactivity in the coolant and containment atmosphere
- Review units of radioactivity measurement:
- Two perspectives needed: effect on instrumentation and effect on human body
- Detectors measure particles (decays) per unit time
  - Curie (Ci) = amount of radioactive material that has the same number of decays per second as one gram of radium. One gram of radium has  $3.7 \times 10^{10}$  decays/sec
  - Becquerel (Bq) = one decay/sec
- Effect on human body depends on amount of energy absorbed and type of radiation
  - Units of absorbed energy
    - Rad = 100 erg/gram (this unit is becoming obsolete)
    - Gray (Gy) = 1 Joule/kg
  - Biological dose = Absorbed energy x dimensionless quality factor for specific radiation
    - Units of biological dose
    - Rem (this unit is becoming obsolete)
    - Sievert (Sv)
    - Absorbing of 2 Gy of energy with quality factor=5 results in a dose of 10 Sv

## 1.1 Sources outside the fuel

- For water-cooled reactors, any oxygen dissolved in the coolant transmutes to radioactive nitrogen
  - $^{16}\text{N}$  has a very short half-life, will trigger gamma-monitoring alarms inside containment
  - Not of concern to public during an accident, but important to maintenance personnel
  - No longer generated in significant amounts once the reactor shuts down
- For heavy water reactors, tritium (one proton, two neutrons) is generated in the heavy water (one proton, one neutron) is exposed to neutrons. It builds up in the RCS and moderator. Darlington RCS has  $\sim 0.1$  Ci/kg.
  - Tritium has a 12-year half-life and is readily absorbed through skin and lungs, is present in containment as vapour leaking from valves and fittings
  - Tritium is of major concern to maintenance personnel, but analysis shows it is less dangerous to public in an accident than radionuclides released from fuel
  - Driers that are part of the internal ventilation system remove water vapour
- The RCS also contains dissolved activation products and some gaseous fission products
  - Structures near the core absorb radiation, become radioactive, are dissolved and transported around the RCS. Deposited in piping boilers or removed by ion exchange columns
  - Iodine is always present (normally 1500Ci in Darlington RCS), removed by IX columns.
  - BWRs carry very few radionuclides in coolant due to constant outgassing while boiling, radionuclides constantly plate out (deposit) in steam systems
- Containment atmosphere is therefore slightly radioactive at all times, but less so for BWRs



## 1.2 Sources inside the fuel

- The fresh fuel is only weakly radioactive, weak alpha and neutron emitter
- Practically all radionuclides originate with the fission process
  - Each fission of a uranium or plutonium nucleus generates two unequal fission fragments, multiple possibilities for the outcome
  - Typical fission fragment mass numbers are 95 and 135, corresponding to atomic number 43 (technetium), 55 (cesium)
  - They carry off most of the 200 MeV released from the fission as kinetic energy
  - They are too heavy to travel more than a few microns in the ceramic  $\text{UO}_2$  fuel
  - Remain immobilized unless they happen to be gases, or unless fuel integrity is lost
  - Gases (iodine, krypton, xenon) diffuse through fuel but are confined by the fuel sheath (cladding) and stay in the gap between the fuel and the cladding
  - Both fragments are extremely unstable (they start with too high neutron:proton ratio) and do not become a stable nuclide after emitting just one particle
  - Fission products emit radiation and/or transmute (become different chemical element) many times before reaching a stable state
- Estimate the inventory of fission products accumulated in the fuel:
  - A 900 MWe reactor actually generates ~2500 MW of thermal power
  - 1 MW thermal power corresponds to  $3 \times 10^{16}$  fissions per second and consumes 1 g of  $^{235}\text{U}$  per day
  - Starting with fresh fuel, after a year, you have  $1 \times 10^3$  kg fission products in the core assuming none decay to stable state
  - In LWRs, about 1/3 of the fuel is replaced every year, larger fraction with heavy water reactors

- **Equilibrium fission product inventory will therefore exceed 1 kg/MWe, assuming each fission generates one long-lived isotope (oversimplification, probably an overestimate)**
- **Spent fuel after removal from core may be removed through a special penetration to a storage area outside containment, or it may be stored inside**
- **Fuel handling accidents (without any pipe break) can therefore cause high radiation inside containment**

### 1.3 Nature of fission products

- **Depends history of reactor power as a function of time**
- **Too many possible species to consider individually**
- **Classify in about a half-dozen groups by**
- **Half-life:**
  - **Time to decay (not necessarily into something harmless though)**
  - **Refer back to module 2D for collective decay times (corresponds to decay heat)**
- **Volatility:**
  - **Tendency to escape from fuel, if cladding is damaged, as fuel is heated and melts**
  - **How likely to remain dissolved in coolant in sump instead of getting into containment atmosphere**
  - **Tendency to plate out (deposit) on containment structures and remain stuck there.**
- **Chemistry:**
  - **Tendency to react with air or water**
  - **Tendency to react with spray/coolant additives, e.g. boron in coolant or hydrazine in sprays**
  - **Forms particulate (typically by oxidizing) or solute (iodine in water)**
  - **Can be adsorbed by filters or not (noble gases barely adsorb)**

- **Biological activity:**
  - **Fission products radiating outside the body are not a significant health problem, so noble gases are not very dangerous**
  - **Danger is with fission products that are readily absorbed by body, have a long half-life and irradiate tissues from within, e.g. tritium, strontium, and above all iodine**
  - **Iodine is absorbed in large amounts by the thyroid gland**

• Example of radionuclide groupings for safety analysis:

<b>Noble Gases</b>	<b>Representative Isotope</b>	<b>Isotopes in this group</b>
$T_{1/2} < 2 \text{ h}$	Xe-138	Kr-83, Xe-135, Kr-87, Kr-89, Xe-138, Xe-137
$2\text{h} < T_{1/2} < 9 \text{ h}$	Kr-88	Kr-83, Kr-88, Xe-135
$9\text{h} < T_{1/2} < 5\text{d}$	Xe-133	Xe-133
$5\text{d} < T_{1/2} < 11 \text{ y}$	Xe-131	Xe-129, Xe-131, Kr-85

**Volatiles**

$T_{1/2} < 1\text{h}$	I-134	Fr, Se(4 isotopes), Te, Br, Rb(3), Cs, I134
$1\text{h} < T_{1/2} < 7\text{h}$	I-135	Br, Se, Cs, Te(3), Sb, I
$7\text{h} < T_{1/2} < 21\text{h}$	I-133	Te, I(2)
$21\text{h} < T_{1/2} < 3 \text{ d}$	Te-132	Sb, Br, Te(2), I
$3\text{d} < T_{1/2} < 8 \text{ d}$	I-131 ***	Sb, I
$8\text{d} < T_{1/2} < 30 \text{ y}$	Cs-137	Sn(3), I, Sb(3), Te(2), Rb, Cs(3)

**Potentially volatile**

Ru-106	Ru(4), Rh(5)
--------	--------------

**That was classification by half-life and volatility.**

**Consider now biological effects:**

Thyroid	Iodine	Serious health hazard
Whole body/ other organs	Ce, Ru, Cs	Hazardous
External	Kr, Xe,	Slight hazard
	Te	Moderate
Bone, lung	Ba, Sr	Hazardous

**Classify also by contribution to fuel activity (kilo-Curies per megawatt of thermal power):**

Life	Element	Activity at shutdown	Activity after one day	Boiling point (degrees C)
Short	Br	30	0	
	Kr	120	.3	
	I	280	55	190
	Xe	260	50	
	Te	300	35	1400
Long	Kr	.6	same	
>1 yr	Sr	45		1400
	Ru	10		
	Cs	5		700
	Ce	50		
	Ba	50		1600

## 2.0 Implications for containment design

### Basic procedure:

- The regulatory agency specifies the allowed maximum dose to a member of the public
- Radionuclide concentrations inside containment atmosphere are estimated for the worst credible accident scenario
- Maximum pressure inside containment is estimated for the worst credible accident scenario to get the design pressure
- Possible radioactivity releases before buttonup are calculated
- The many paths between a radionuclide release from containment and a member of the public are analyzed to find the one that comes closest to the allowed maximum dose
- Putting together these calculations determines the maximum allowed release, the sum of leakage and venting and/or controlled discharge
- Typical allowed leakage rates are a fraction of a per cent of per day at 2-4 bar, slightly higher leakage rates allowed for BWRs

Will first look at pathways from a containment release to the public, then the paths from the fuel into containment, finally the behaviour of radionuclides inside containment.

### 3.1 Calculation of dose to public and derived emission limits

- Regulatory agency specifies the maximum allowed dose to a member of the public
- Analysis of pathways leading to public leads to the maximum allowed release of a particular radionuclide
- Canadian dose limits, following the guidelines of the International Commission on Radiological Protection:

Whole body, reproductive organs, bone marrow		5 milli-Sievert/year
Skin, bone		30 mSv/yr
Thyroid (adult)	absorbs iodine	30 mSv/yr
Thyroid (child <16)	absorbs iodine	15 mSv/yr
Extremities (hands, feet)		75 mSv/yr
Other organs (eye)		15 mSv/yr

- To model radionuclide transport from containment to public
  - Consider a series of compartments (soil, atmosphere, plants, animals, groundwater, surface water) each containing inventories of various radionuclides.
  - Divide population into groups according to distance from plant, and age distribution
  - Transport of radionuclides between various compartments leads eventually to internal and external dose estimates for the various population groups
  - Identify the critical population group: group that would receive the dose closest to the limit
- Derived emission limit for a particular radionuclide group : the amount which, if released during one year, would result in a typical member of the critical group receiving the maximum dose.

### 3.2 Factors affecting dose to public

#### Factors affecting pathways followed by radiation

- **Weather patterns are most important. Dispersal of radioactive plume depends on**
  - **Horizontal wind strength and direction**
  - **Stability of atmosphere, whether hot air near ground level rises or is trapped in an inversion layer**
  - **Reduced dose if no inversion layer, wider dispersion/dilution of radiation if plume can rise and spread**
  - **Much worse ground level pollution if low mixing height**
- **Land and water use**
  - **Type of crop is significant**
  - **Vegetables with large flat leaves (entire surface for radionuclide deposition is eaten)**
  - **Fruit and vegetables that are peeled/not peeled before consumption**
  - **Grain, animal fodder both delay and concentrate radionuclides in animal products**
  - **Livestock**
  - **fishing**
- **Result of analysis almost always shows that inhaled iodine is the predominant concern, strontium second**
- **Absorption of radioactive iodine is blocked if iodine pills are taken just before exposure to radioactive iodine. The thyroid is saturated with nonradioactive iodine and cannot absorb any more.**



#### 4.0 Radionuclide release from the fuel into the coolant

- Normally totally confined to ceramic fuel pellet, except gaseous fission products (I, Xe, Kr)
  - A small fraction of the gaseous fission products diffuse through the fuel matrix and through microscopic cracks in the fuel cladding, even if sheath is intact
  - May be an increase in coolant gaseous fission products associated with reactor power changes (referred to as the “iodine spike”)
  - Coolant is constantly monitored for gaseous fission products as indication of fuel failure
  - Iodine is removed by ion exchange columns in coolant purification system
- Normal fuel pellet interior temperature is ~800 C
  - Do not expect impaired fuel integrity during LOCA if ECC operates as designed.
  - Problems with sheath start around 1000C
  - Zircaloy sheath reacts with water to generate hydrogen & gaseous fission products escape
  - Pellets fall to bottom of pressure vessel, ceramic grain structure changes with heating
  - Heating and melting of fuel facilitate diffusion of other fission products towards fuel surface
  - For safety analysis assume all iodine escapes if  $T > 1200\text{C}$ ; all fission products escape if  $T > 2000$
  - Long-term leaching of fission products from cool failed fuel must also be considered
- Once fission products are circulating inside RCS, variety of very complex processes occur
  - Normal circulation in RCS is disrupted, may be stagnant areas with steam around the fuel, or steam bubbles circulating, may be very high velocity flows near break
  - Fission products may stay dissolved in liquid, travel with aerosol droplets, or in gaseous form
  - Chemical reactions occur between fission products (cesium + iodine), or between fission products and water (HOI), or between fission products and the borate added to control reactivity in LWRs

- Fission products may deposit (plate-out) inside piping surfaces and stick there when aerosol collides with piping interior walls
- Fission product release from the coolant into containment depends on
  - Break flow magnitude, time-dependent
  - Dilution by ECC injection, time-dependent
  - Location of break (upstream or downstream of fuel)

## 5.0 Radionuclide behaviour inside containment

- Processes to consider:
  - Jet scrubbing removes 98% of radionuclides in high-pressure break flow from atmosphere
  - Chemical reactions
    - with other radionuclides, borate, hydrazine
    - particularly iodine
  - Aerosol behaviour
    - Gravitational settling (falling), agglomeration (droplets stick together), entrainment (droplets are carried along by air), turbulent deposition of droplets on walls, diffusio-phoresis (migrate up temperature gradient)
  - Adsorption (plate-out) and desorption on containment structures
  - Transport between containment rooms - natural convection, fans
    - Some rooms will leak more to environment than others, e.g. vacuum building very leak-tight
  - Condensation/evaporation on structures, in bubblers or suppression pool
  - Particulate and iodine removal by sprays, air coolers, vapour removal system (dryers)
    - High flow velocity in air coolers ensures aerosol deposition on fins, as well as removal by condensation

- **Solution in liquid pool, partition of iodine into liquid and air**
- **Radioactive decay, transmutation**
- **For practical purposes, can also define a “plateout half-life” :**
  - **1hr to 1 day for iodines**
  - **10-100 days for others**
  - **infinite for noble gases**
- **Jet scrubbing mechanism for radionuclide removal**
  - **Experiment on the WALE test facility show that only 2% of radionuclides transported by RCS break flow end up in containment atmosphere, as aerosol, particulate, or gaseous**
    - **Flashing of superheated liquid causes rapid expansion of steam bubbles**
    - **Remaining liquid component is fragmented into a fine aerosol**
    - **Iodine is transported with the liquid component, does not flash with steam (why?)**
    - **Aerosol disperses as jet expands to form a plume by entraining the surrounding air, loses momentum and slows down**
    - **Jet/plume suffers impingement/deflection on striking containment structures**
    - **Aerosol droplets from the break are almost all deposited on containment structures**
    - **In addition, any aerosol droplets in the region surrounding the jet are entrained and also deposited on structures. This is the jet scrubbing mechanism**
    - **Highly effective mechanism, ensures  $<1/50$  of radionuclides from break flow end up in containment atmosphere as aerosol or particulate**
    - **Jet scrubbing ensures low aerosol density,  $\sim 10\text{-}20$  g/m<sup>3</sup>.**
- **Older estimates for radionuclide release from containment were much too high**

## 6.0 Routes by which radionuclides can escape from containment

- Three modes: through penetration, short term release through stack, long term release by leakage
- Release through penetration
  - Recall the steam lines to the turbine-generator lead outside containment
  - In CANDU design, boiler steam relief valves vent to atmosphere. (In BWR design, steam lines to turbine close during LOCA, no steam to atmosphere.)
  - If there is a boiler tube leak at the time of LOCA, will be a brief release of radionuclides because steam relief valves open for rapid cooling of RCS
  - CANDU design includes D2O detectors in some H2O circuits, e.g. boilers, some heat exchangers
  - Also possible if part of ECC is outside containment and reverse flow through ECC piping occurs.
- Short term release before containment isolation:
  - Possible if the LOCA is small
  - Air coolers and structures absorb enough energy to delay containment isolation occurring automatically on high pressure
  - More a theoretical possibility, alert operator will initiate isolation manually
- Short term release during overpressure: dominant dose contribution if no containment failure
  - Leakage through microscopic cracks around penetrations, structure joints, airlock components
  - These leakage paths may be plugged by aerosol droplets and condensation, or fission products can deposit in the microscopic cracks, so not as bad as one would assume from dry air leakage rate
  - High pressure could cause reverse flow through the intake of the ventilation system before the intake dampers close as part of containment isolation

- **Deliberate containment overpressure relief (venting) during the overpressure transient through scrubbers for some containment designs.**
- **Long term release through filtered discharge system**
  - **All containments must eventually discharge containment gases to atmosphere if they are to remain near atmospheric pressure in the long term**
    - **Inleakage during the immediate post-accident negative pressure phase slowly raises pressure for containments designed to be subatmospheric after an accident**
    - **Instrument air (from pneumatic devices) enters containment at  $\sim 0.1 \text{ m}^3/\text{s}$ , unless the compressed air system intake is inside containment**
  - **Better to discharge containment atmosphere through filters than let it leak out.**
  - **Filter efficiency is very high**
    - **Exception: noble gases and tritium, remove only 1%**
    - **Activated charcoal (designed for iodine only) adsorbs 99.9% of  $\text{I}_2$ , HOI, 97% of  $\text{CH}_3\text{I}$**
    - **HEPA (particulate) filter absorbs >99% of iodine, >99.9% of particulate**
  - **Much depends on length of time before filtered discharge becomes necessary**
    - **Waiting even 2 days reduces public dose by factor of 50, 4 days by factor of 100**
    - **Fission products in long-term containment atmosphere are very different from fission products right after accident**
    - **Only noble gases and very volatile vapours will still be airborne**
    - **Suspended particulate, droplets containing fission products will have settled in the sump liquid pool or plated out on the walls.**
    - **Short-lived isotopes will have decayed**

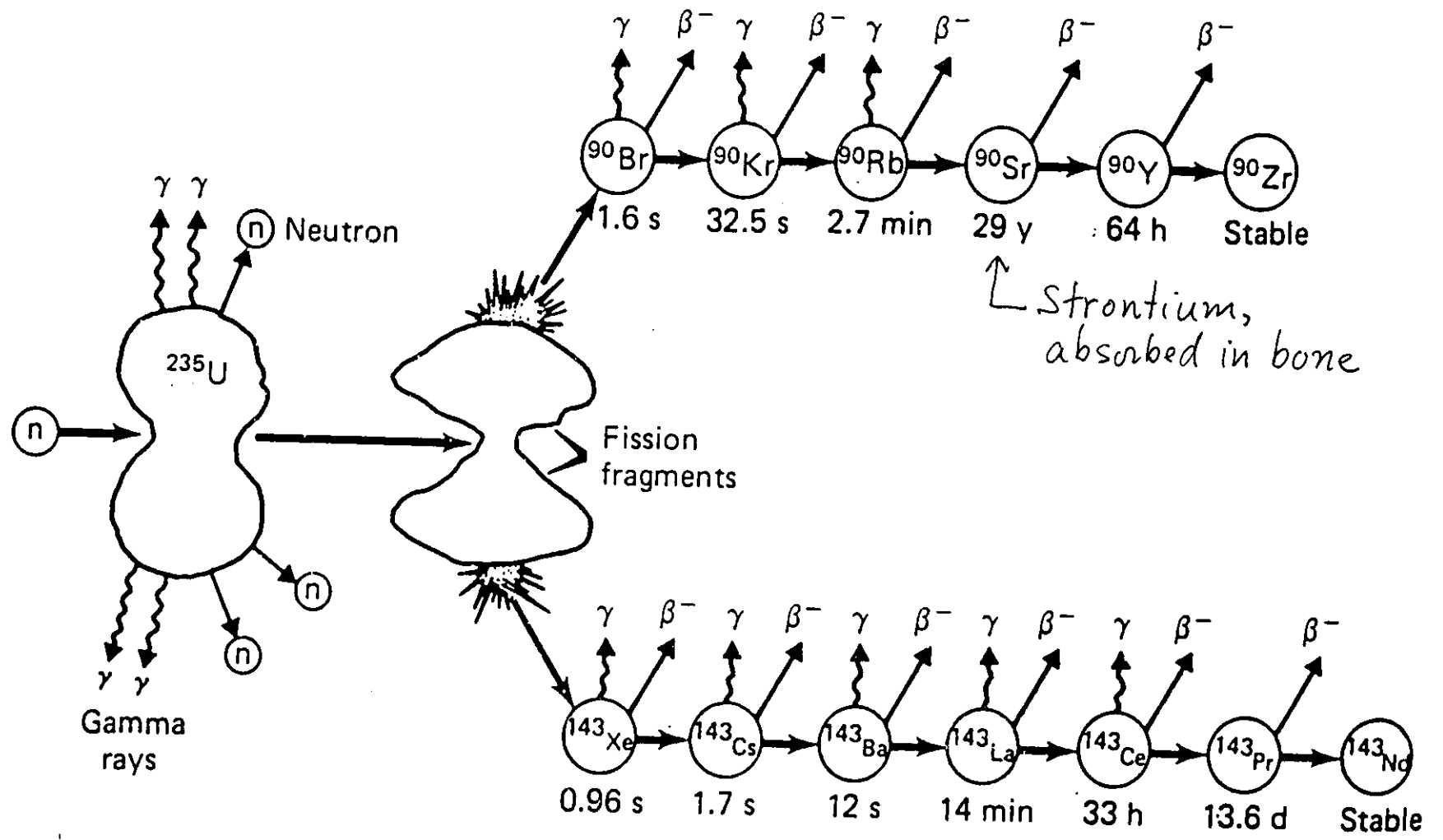

Neutron fission of  $^{235}\text{U}$  showing two representative fission product decay chains.

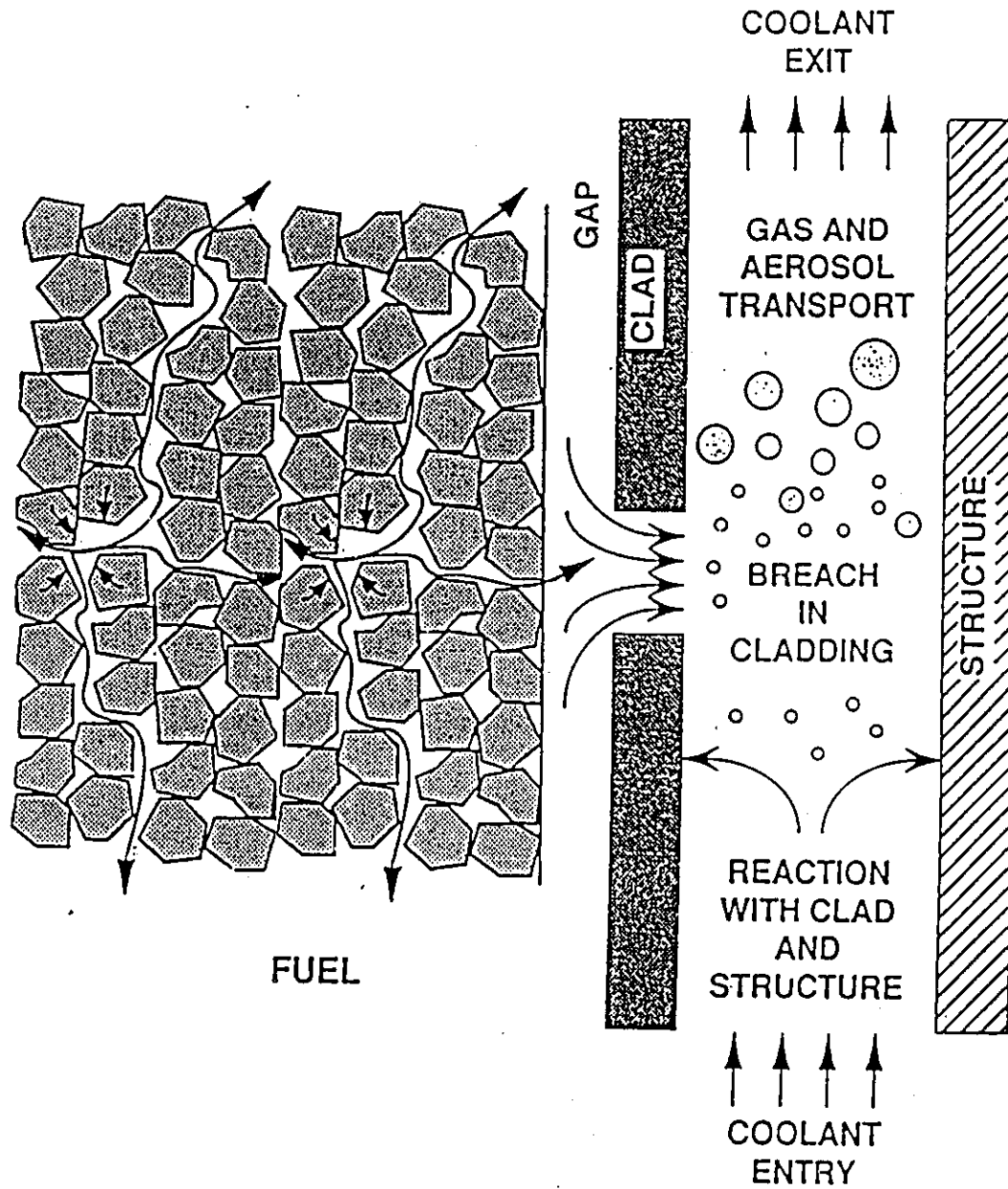

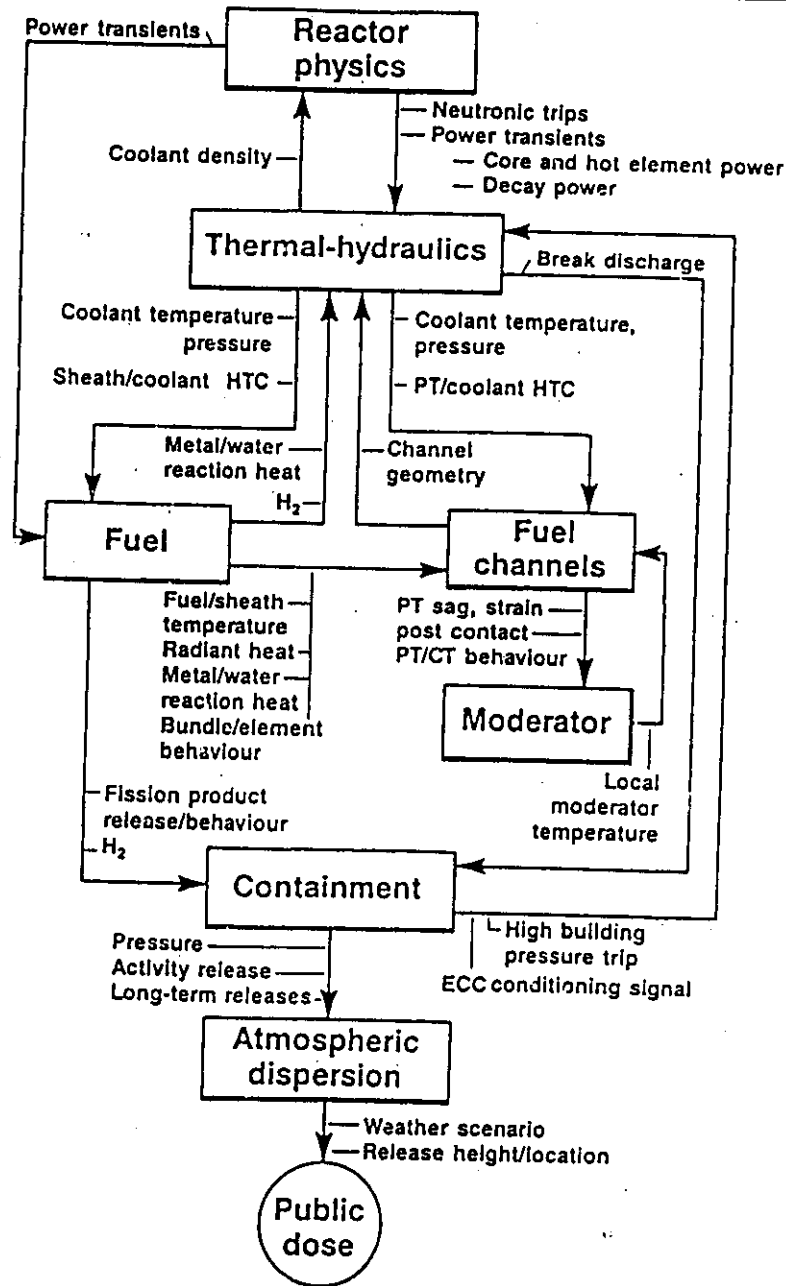



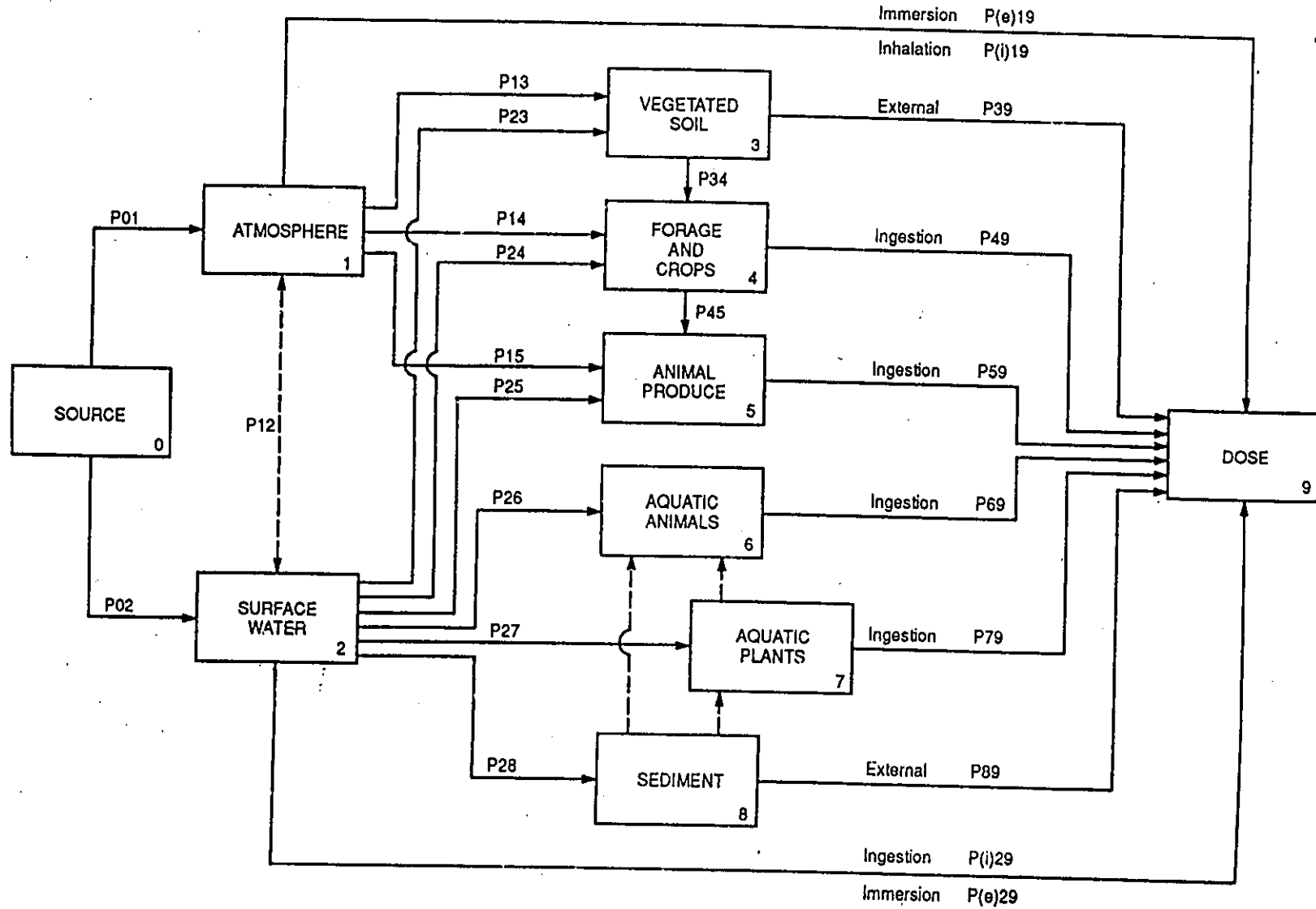

## **CHAPTER 2: HYDROGEN, RADIONUCLIDES AND SEVERE ACCIDENTS**

### **MODULE C: SEVERE ACCIDENTS**

#### **MODULE OBJECTIVES:**

**At the end of this module, you will be able to describe:**

- 1. The physical phenomena occurring during severe accidents**
- 2. The significance of these phenomena for containment design**
- 3. Filtered-vented containments**
- 4. Core-catchers**

## 1.0 Definition of severe accident:

Inadequate core cooling leading to degradation (disintegration) of core structure (pressure vessel, fuel rod supports) and fuel melting.

### Example 1: Three Mile Island (TMI), a BWR

- Reactor was shutdown shortly after problems with feedwater, no reactor overpower
- Inadequate cooling of the core despite ECC injection (the core was actually uncovered) while substantial decay heat was still being generated
- Core was uncovered by operator error due to inadequate training; operators were also misled by incorrect valve position indication
- Fuel melted (meltdown), and hydrogen explosion within containment
- Insignificant radionuclide release to public because of containment design: 18 Ci iodine,  $6 \times 10^6$  Ci xenon
- Although it was designed only to survive the overpressure due to a large pipe break, the use of large conservative safety margins resulted in a containment structure that survived an unforeseen accident

### Example 2: Chernobyl, an RBMK design without containment

- Rapid uncontrolled increase in reactor power due to reactor design error and operator errors
- Shutdown and cooling mechanisms overwhelmed
- Reactor building structures destroyed by explosion, meltdown
- Graphite moderator burned and much of radionuclide inventory dispersed
- Massive public evacuation, large dose to public

## **Doubtful that any containment could have withstood such an explosion**

- **Not really fair to compare the TMI and Chernobyl; but RBMK containments are considered inadequate**
- **Containment designers assume in their worst case accident analysis that the reactor does shutdown successfully**
- **They may assume other failures occur, e.g. failure of ECC, failure of some redundant equipment, hydrogen explosion, meltdown - but not failure of shutdown systems**
- **No lessons from Chernobyl for containment design, except for unlucky countries still dependent on RBMK reactors**

## **2.0 Lessons learned from TMI**

- **Utilities (electrical power companies) worldwide established the IDCOR (Industry Degraded Core Rulemaking), a research program to analyze severe accidents**
- **Questions were: how are severe accidents caused, how does the nuclear plant behave, what design features are effective in mitigating problems**
- **Focused attention on containment as the key factor in reducing the risk to the public from severe accidents**
- **Most important phenomena are those leading to containment failure and fission product dispersal**
- **Key question is whether containment will fail immediately after the accident.**
- **Later failure much less serious, radionuclides have decayed or been absorbed/adsorbed**

### **3.0 Physical phenomena during severe accidents**

#### **Hydrogen generation and explosion**

#### **Radionuclide release**

#### **Loss of heat sink (to ECC, air coolers, spray recirculation)**

#### **Steam explosion**

- **Molten fuel (corium) comes into contact suddenly with a large amount of cold water, e.g. when structural failure causes a large cool tank to empty onto the core at 2000 C**
- **Steam expansion velocity > speed of sound, which defines an explosion**
- **Such accidents well-known in the steel industry**
- **Further structural damage due to shock waves, liquid slugs (blobs of liquid), missiles (explosion converts damaged core structure fragments into high-speed projectiles)**
- **Experiments show that only a few per cent of the heat transferable to the water is converted to mechanical energy**
- **Not as serious as first thought**

#### **Slower overpressure due to rapid steam generation**

#### **Bypass of containment envelope**

- **Open valves or problems with interfacing systems, e.g. ECC pipes leading outside containment**
- **Isolation failure**

#### **Overpressure due to noncondensable gas buildup**

- **Concrete reacts with molten fuel to generate CO<sub>2</sub>, no way of removing it, can't condense**

#### **Molten fuel burns through the basemat (the concrete under the core); this is called melt-through**

#### **High-pressure melt ejection**

#### **4. Effects of TMI on containment design**

**Severe accidents are now considered in containment design**

**IDCOR studies concluded:**

- **Early failure due to explosions unlikely**
- **Other problems would cause late failure, if failure occurred at all.**
- **Melt-through unlikely, core-catchers useless**
- **Filtered-vented containment unnecessary**
- **Heat sinks are adequate**

**Actual post-TMI design changes:**

**Hydrogen management**

- **Included in all new designs, retrofitted to older designs**
- **Igniters, recombiners, inerting**
- **Intense research effort into hydrogen problems continues to this day**

**Filtered-vented containments**

- **During the peak pressure of severe accidents (as opposed to normal pipe break-type accidents), brief overpressure relief (<1 hour) through filters/scrubbers**
- **Not a universal design feature**
- **Retrofitted to some European plants, included in their new designs**

**Core-catchers**

- **Structures right under the core to absorb energy from molten fuel and solidify it**

- **Not an IAEA requirement**
- **Much theoretical discussion in the literature**

#### **Passive heat sinks**

- **Included in all future advanced designs**
- **Large amounts of cool water in tanks, cooling by natural convection**

#### **4. Filtered-vented containments**

**German and Swiss regulatory agencies recommend/require filter-venting for severe accidents.**

**Must vent 1% of reactor decay heat in first 30 min after shutdown**

**Example: KRB II, a new 1300 MWe BWR built by KWU , with a cylindrical prestressed, steel-lined containment, pressure suppression pool, no pre-inerting of drywell because they want dry-well access for maintenance**

- **Containment failure estimated at 11 bar, so venting is designed to limit pressure to 7 bar (absolute pressure)**
- **Requires steam vent flow of 14 kg/s at 7 bar for 1% decay heat**
- **Vent flow connected to pressure suppression chamber, goes from there to the filter unit**
- **Siemens-KWU filter unit is Venturi scrubber, followed by demister and stainless steel filter**
- **Venturi scrubber is a small pressure vessel (operates at approximately containment pressure) with a liquid pool**
- **Lines from containment terminate in submerged Venturi nozzles**
- **Nozzles break the incoming flow into small bubbles that are scrubbed clean of particulates and iodine by the liquid.**

**A similar venturi-scrubber are made by Sulzer-EWI with integral filter**

**Sweden and France use scrubbers with sand or gravel**

## **5. Core-catchers**

**None actually installed as of 1995**

**Problem is that most design proposals depend on water cooling of molten fuel, but contact between this water and the molten fuel is possible and could lead to steam explosion.**

**Designers either minimize possibility of such contact or argue that the steam explosion will not be significant.**

**Examples:**

**(1) Multiple vertical channels lined with refractory material (high melting point) under the core with passive external water cooling for the channels**

**(2) Allow corium (molten fuel + debris) to spread out horizontally in a space under the floor, then water cooling from above to solidify it.**

**Next generation of French-German-European PWRs may have this concept**



J. Koldic / Nuclear Engineering and Design 157 (1995) 299-310

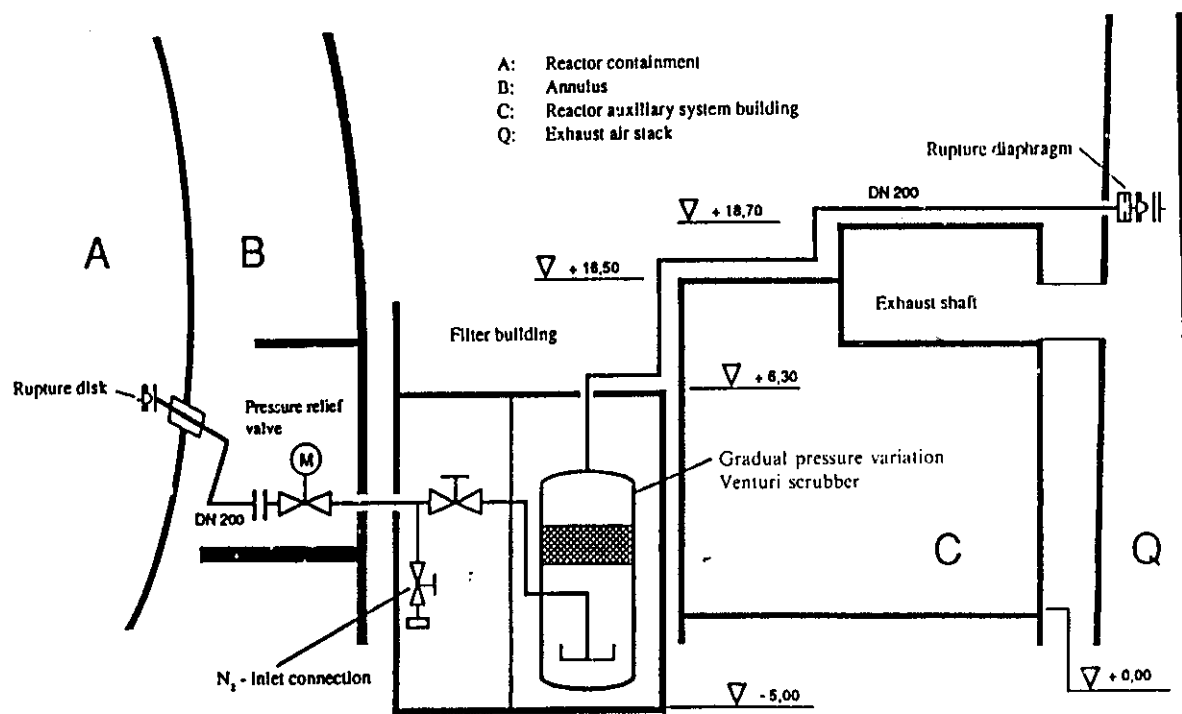

Fig. 3. Disposition of the pressure relief system within the buildings.

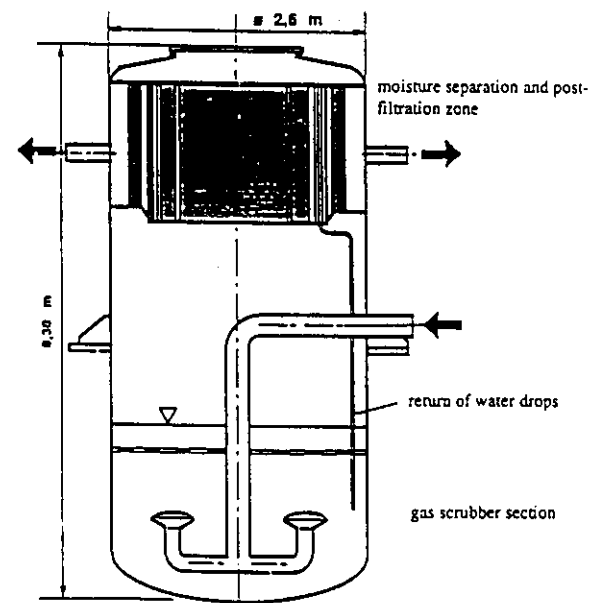

Fig. 4. Gradual pressure variation Venturi scrubber with integrated metallic filter.

H.A. Weisshäupl, D. Bittermann / Nuclear Engineering and Design 157 (1995) 447-454

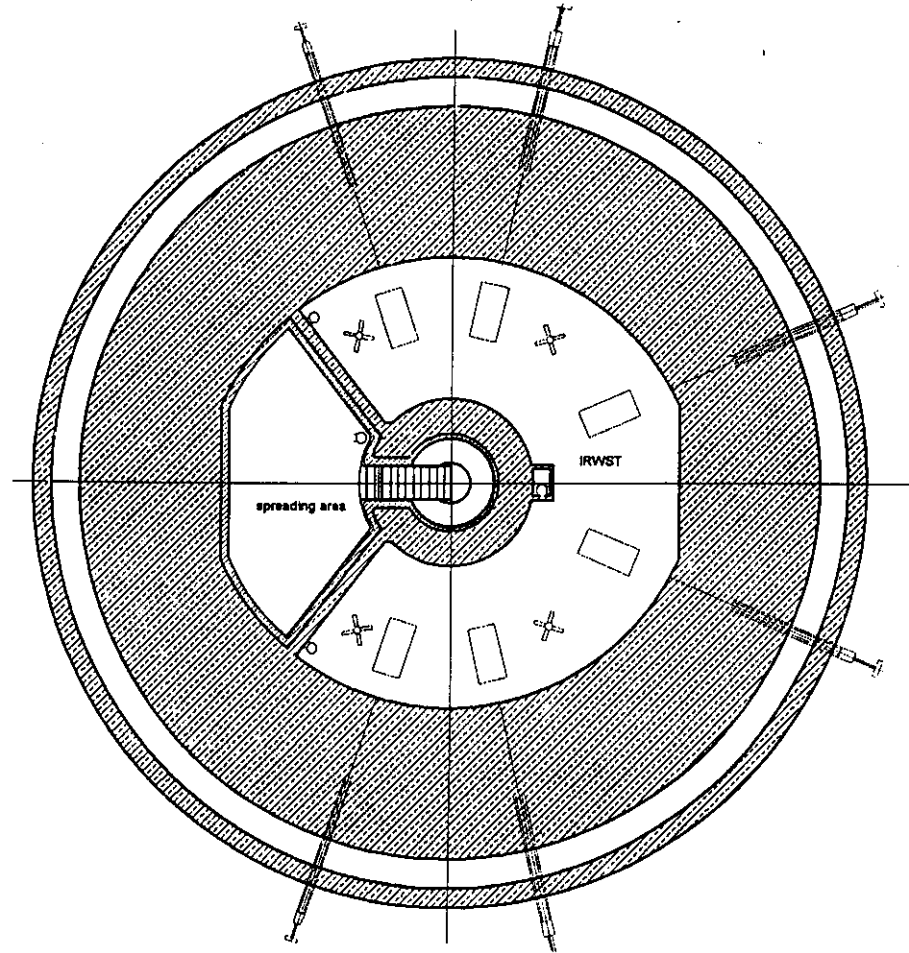
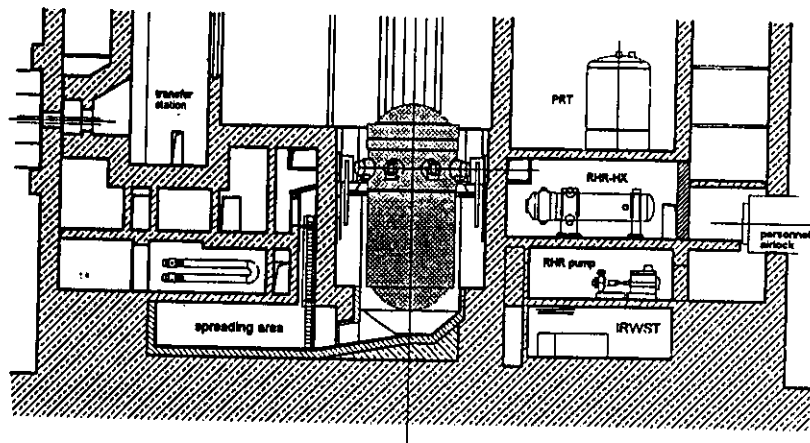
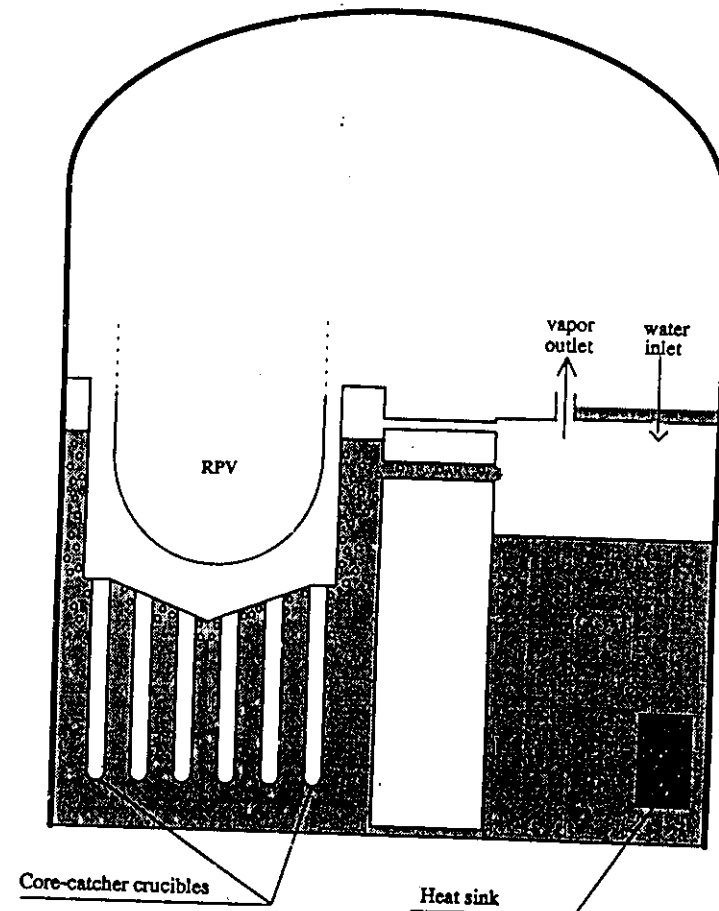
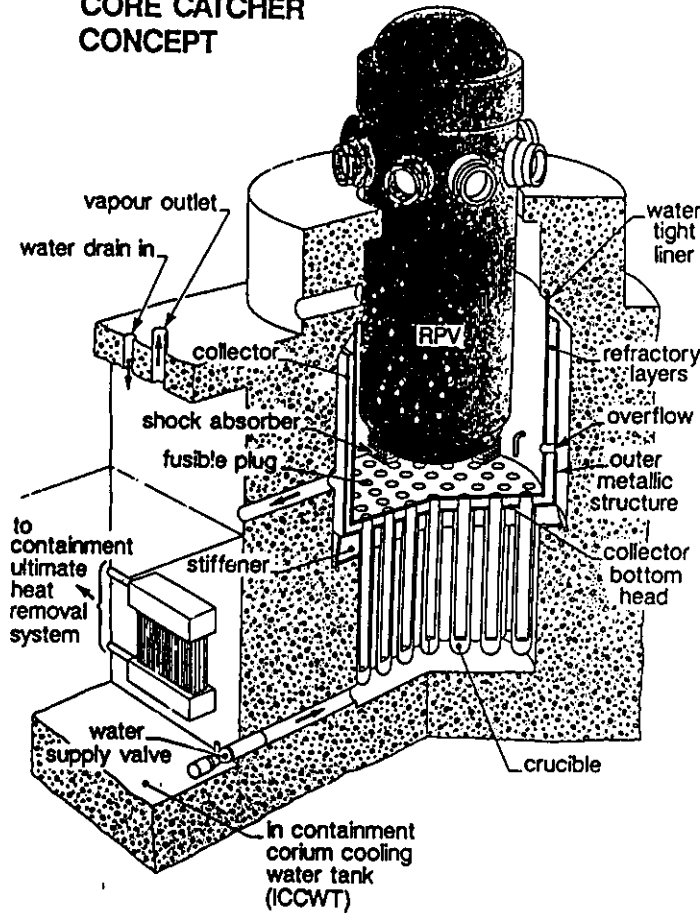

Fig. 1. EPR layout for spreading and stabilization of core melt.

I. Szabo et al. | Nuclear Engineering and Design 157 (1995) 417-435

### BIRD'S EYE VIEW of the MULTI-CRUCIBLE CORE CATCHER CONCEPT



Thermalhydraulic of core-catcher cooling system.

Fig. 1 Bird's eye view of the multi-crucible core-catcher concept.