

CHAPTER 1: INSTRUMENTATION EQUIPMENT

MODULE 7: Digital Computer Control

The Digital Computer

The essential components of a modern digital computer may be sketched as follows:

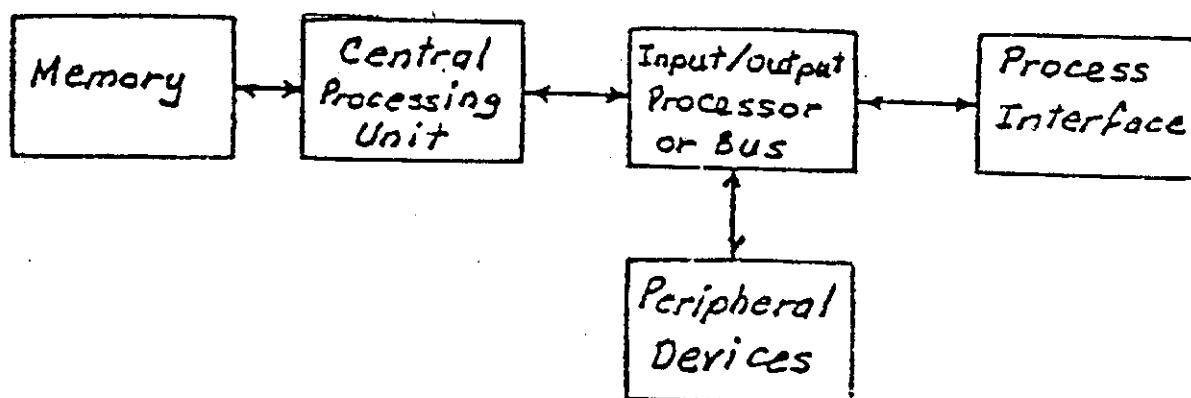

- The program instructions and data are stored in the memory, part of which can be "read-only-memory" (ROM).
- The central processing unit (CPU) decodes and executes the instructions. The basic arithmetic functions are addition and subtraction. The decisions consist of branching or not.
- The I/O processor or bus connects the CPU to various peripheral devices.
- The computer communicates with process instruments through special devices.

Analog and Digital Data Representation

- In the communication between the computer and the process instruments, it is necessary to convert process analog data to digital data and vice versa.
- Let us consider a process temperature transmitter with a range of 50 to 150°C. In theory, the analog signal out of the transmitter can vary continuously between 4 milliamperes (ma) when the temperature is 50°C, and 20 ma for a temperature of 150°C.
- In practice the sensitivity of the transmitter is limited, and we must specify its resolution. Note that we are not considering here the accuracy of the measurement, which would be a function of the temperature sensing element (e.g., thermocouple or resistance thermometer), but only of the reproducibility of a given measurement.
- In order to store the transmitter output signal into the computer memory, it must be converted to a digital quantity. All modern computers use the binary number system to code data. Each binary digit or "bit" can have one of two values, 0 or 1. In order to facilitate digital data interpretation, binary numbers are coded in groups of 3 to form "octal" ($2^3 = 8$) or in groups of 4 to form "hexadecimal" numbers ($2^4 = 16$).

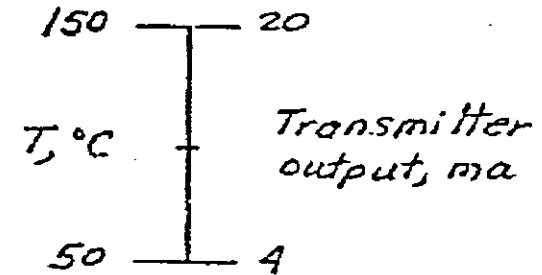

Octal Numbers		Hexadecimal Numbers			
000	0	0000	0	1000	8
001	1	0001	1	1001	9
010	2	0010	2	1010	A
011	3	0011	3	1011	B
100	4	0100	4	1100	C
101	5	0101	5	1101	D
110	6	0110	6	1110	E
111	7	0111	7	1111	F

The analog-to-digital converter (ADC) is the device that digitizes the analog signal from the transmitter. The resolution of the digitized number is determined by the number of bits generated by the ADC. Since n bits are capable of differentiating 2^n states, the resolution is given by 2^{-n} .

Process ADC's have eleven or twelve bits, with resolutions. Note that there is no need to assign one bit to the sign of the number since the transmitter output is always of the same sign.

The following table illustrates the result of the output of the ADC for various temperature values.

T, °C	Transmitter Output, ma	ADC Output (11-bit)
50	4.0	00 000 000 000
75	8.0	01 000 000 000
100	12.0	10 000 000 000
125	16.0	11 000 000 000
125.05	16.008	11 000 000 001
149.95	19.992	11 111 111 111

Before the ADC output can be stored in the computer memory, it must be shifted one bit to the right and the leftmost bit set to zero. This is because the numbers stored in the computer memory are normally treated as negative if the leftmost bit is one, and positive if it is zero.

For readout to the operator, or for use in complex engineering calculations such as heat balances, the number must be converted to engineering units, i.e. degrees C. For this we must store in the computer the lower bound and the span of the temperature range, i.e., 50 and 100°C respectively.

The transferred quantity in engineering units must then be represented as a floating-point number e.g., $75^\circ\text{C} = 0.75 \times 10^2$

Analog to Digital Conversion

- The conversion of the analog signal to a digital number for storage in the computer memory is a stepwise process that can be performed by the analog-to-digital converter (ADC) at a much faster rate than the typical process signals can change.
- The ADC output is usually through eleven or twelve lines, one for each bit, which are transferred in parallel.
- The controller sends back to the computer a signal that flags that a conversion has been completed.

There are a number of variations of this basic scheme:

- in some systems the ADC is capable of storing its output directly into the computer memory while the central processing unit (CPU) performs other functions.
- there are special multiplexers that accept pneumatic (air pressure) signals from the process instrumentation. This saves having to convert each individual signal to an electric signal before input to the multiplexer for plants equipped with pneumatic instruments.

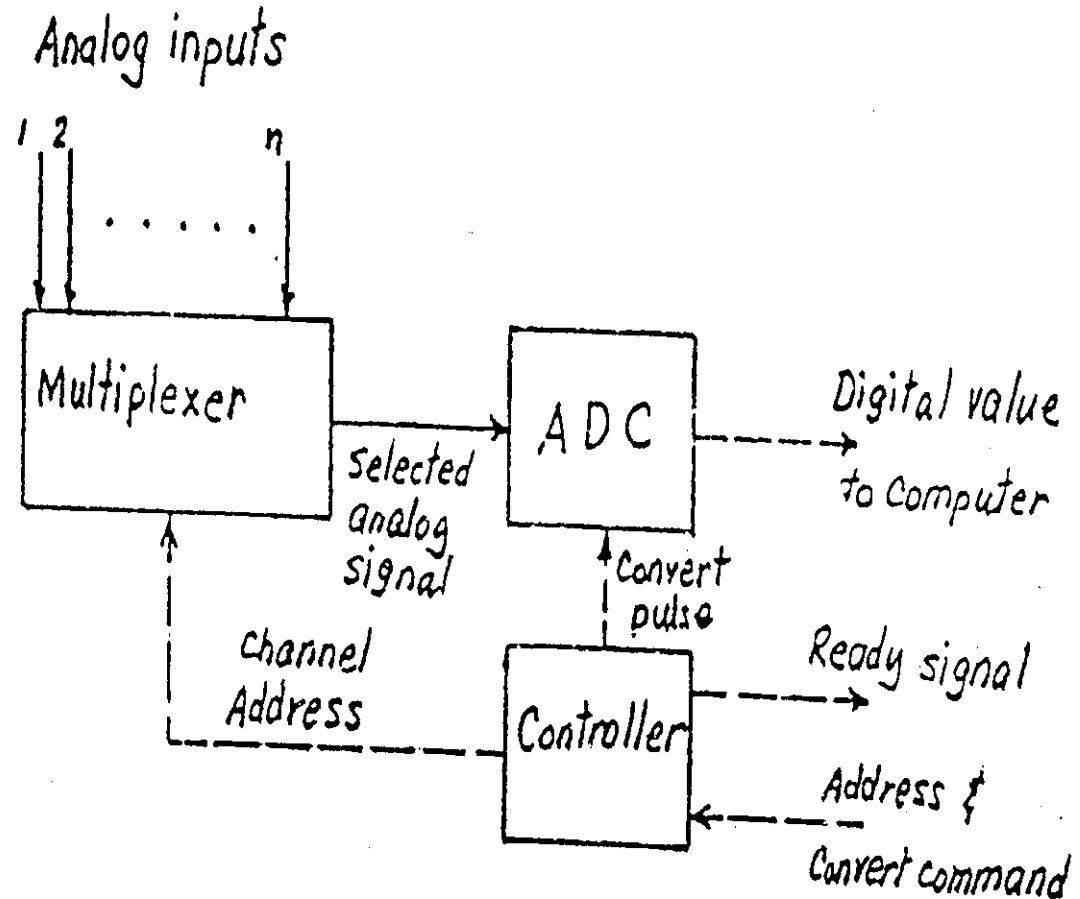

Digital to Analog Conversion

The device that converts a digital number to an analog signal must hold the value of the signal between updates from the computer as the process or analog instrument that receives it must operate continuously on it.

In computer control installations, this hold function is combined with a means for operator intervention in case of computer breakdown.

The output stations can be of two basic types:

- Track-and-hold stations. The analog output is updated periodically to a value corresponding to the digital output from the computer and held constant until the next update time.
- Integrating stations. The analog output is incremented or decremented at each update period by an amount corresponding to the computer output, and held constant until the next update time.

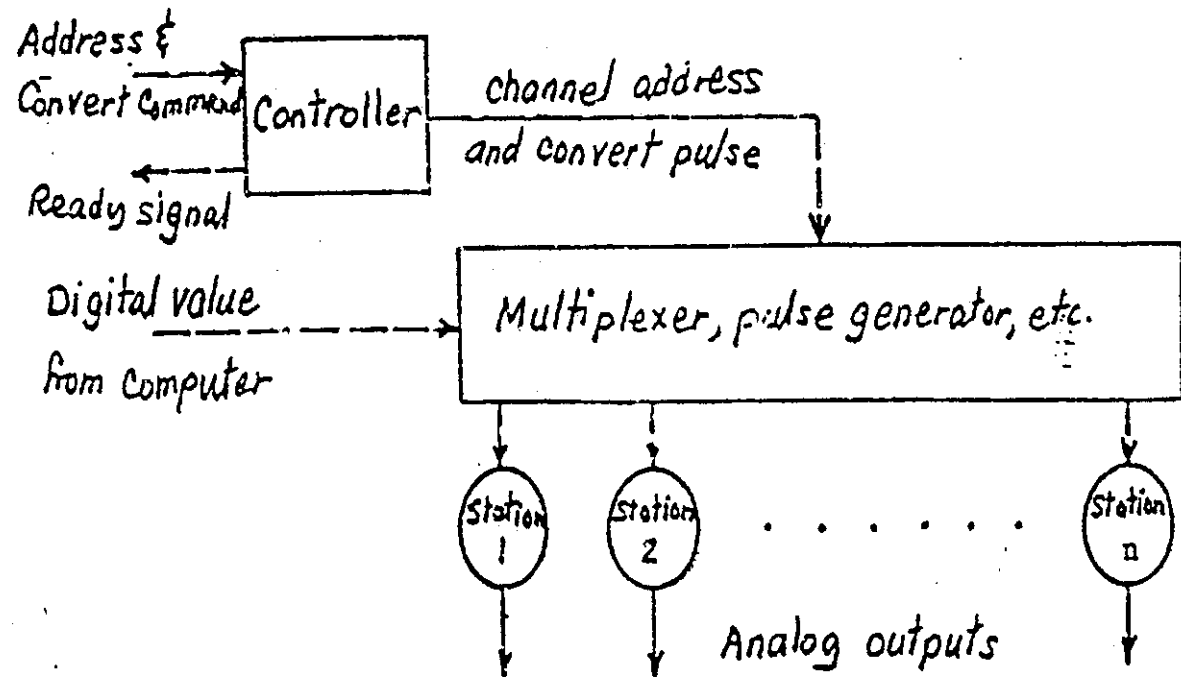

For the first type the computer must output the desired value of the signal, while for the second the computer output is the change in the signal.

Digital computer control techniques

The digital computer is capable of performing all of the basic control functions previously reserved for analog instrumentation. These include feedback and feedforward control, cascade control, override and selective control, and decoupling of multivariable loops.

Feedback Control

The digital computer can perform the PID controller calculation for as many loops as necessary. However, in order to do this, the measured variables must be sampled at uniform intervals of time and digitized for storage in the computer memory. This means that the measured variable is not available to the computer as a continuous function of time, but as discretely sampled values. This can be graphically sketched as follows:

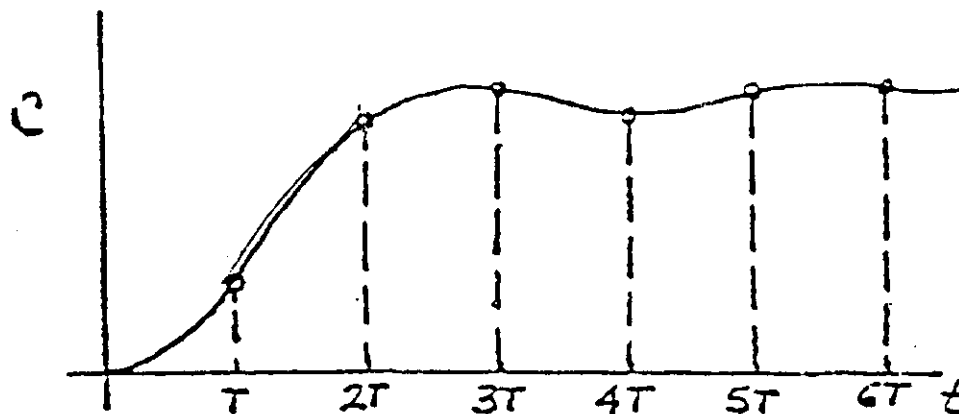

where T is the time interval between samples or sample time. Note that there is loss of information in sampling, namely the response between samples.

Since the measured variable is available only at the sampling instants, the error and the controller output can only be computed at these times.

The output of the controller must be held by the DAC until the next sample and computation. The shape of the signal from the DAC has the following form:

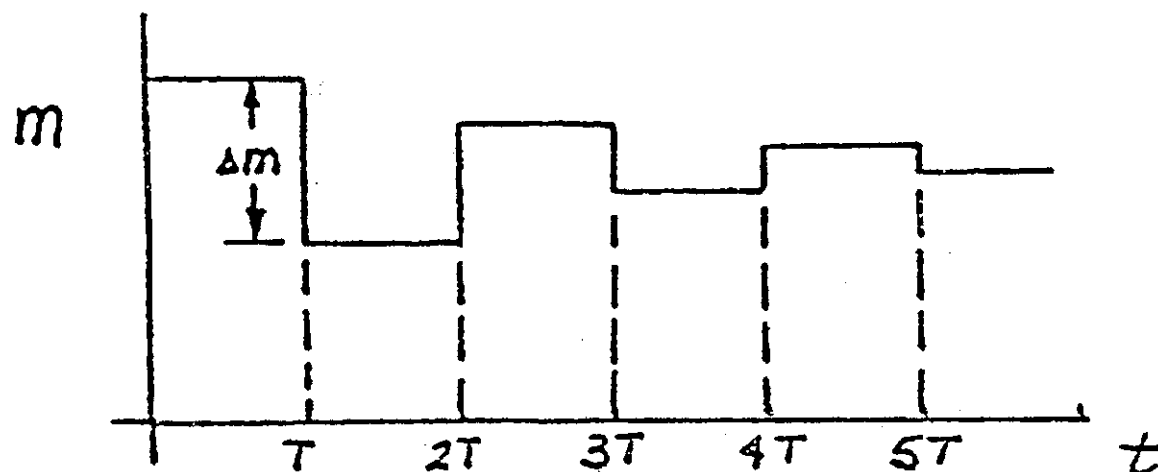

This type of DAC, the most common by far, is also technically referred to as a "zero-order-hold".

Feedback control algorithms, although apparently used as substitutes for analog controllers implying a DDC application, can also be used in supervisory control systems. In this case the output is not a valve position, but the set-point to an analog controller. In both DDC and supervisory installations it is essential that the operator be given the means to take over and override the computer outputs in case of computer failure. This is accomplished by the so-called DDC stations and set-point stations, which usually perform the digital to analog conversion.

The disadvantages of digital feedback control are as follows:

1. Sensitivity to noise in the measured variable that requires filtering. This is also known as "aliasing error" and will be discussed later.
2. Introduction of dead-time effect into the loop which reduces the ultimate gain.
3. Discretization error that causes the derivative action to produce undesirable pulses in controller output.

The discretization error is due to the digitization of the analog measurement. When digitizing a continuous variable, there is a minimum threshold (the low order bit), below which changes cannot be detected. For an eleven (11)-bit converter this threshold is 2^{-11} or 0.0005 of the transmitter range. When the rate of change of the variable is less than one bit per sample, the following sketch represents the contribution of the derivative action:

At the point at which the threshold is exceeded, the input changes by one bit and the derivative assumes a rate of change of one bit per sample. At the next Sample instant no change occurs and the derivative returns to zero. The resulting pulsations in the valve are undesirable. Because of this, derivative is seldom used in digital control algorithms.

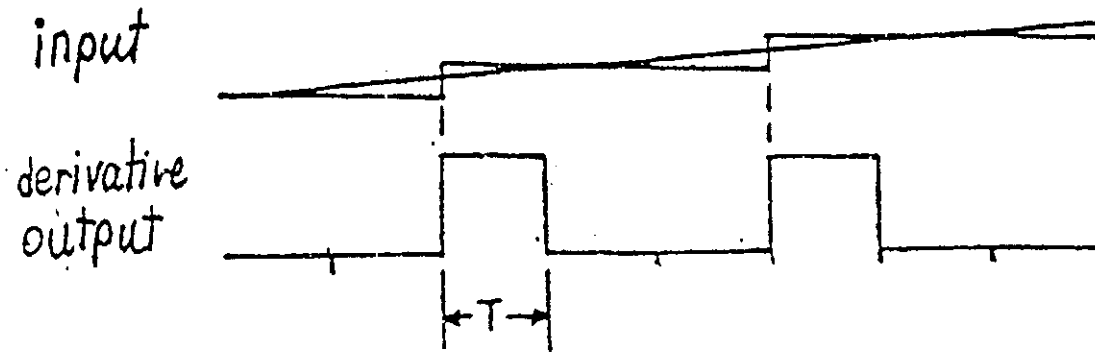

The advantages of digital feedback control are its flexibility and ability to handle slow processes. Flexibility means that algorithms other than standard PI and PID can be used and changed until the best algorithm is found. Algorithms such as proportional, pure integral, proportional action on measurement plus integral on error, etc. can be as easy to program as the standard ones.

The ability to handle slow processes requiring long integral times is an often overlooked advantage. For example, integral times of between 60 and 120 minutes, impractical to obtain with analog controllers, can be obtained by simply increasing the sample time to 10 to 20 minutes. The computer can then make precise corrections at intervals which are in general too short for operators to make manually.

Aliasing Error and Digital Filtering

When a continuous signal is sampled, the sampled values become specially sensitive to any high frequency noise contained in the signal. This is because of a phenomena known as "aliasing error" which is best understood by considering the following diagram of the sampled signal:

Aliasing consists of the generation of a noise signal of much lower frequency than that of the original noise. This lower frequency noise causes a deterioration of the computer performance because it is in the range of the sampling frequency and therefore, in the range of response of the process. Note that the original noise content does not generally affect analog instruments because its frequency is too high to force the typically slow analog components.

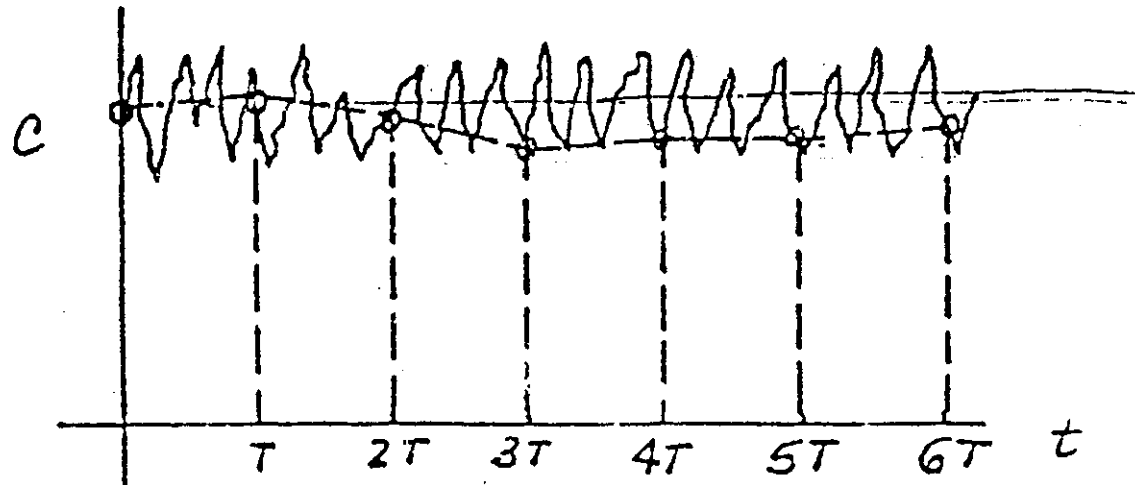

To minimize the effect of aliasing, the sampled signals must be filtered. Virtually all digital control computers provide filter or damping algorithms to reduce the effect of aliasing.