

NUCLEAR POWER PLANT SYSTEMS and OPERATION

Reference Text

Dr. George Bereznai
Professor and Dean
School of Energy Systems and Nuclear Science
University of Ontario Institute of Technology
Oshawa, Ontario
george.bereznai@uoit.ca

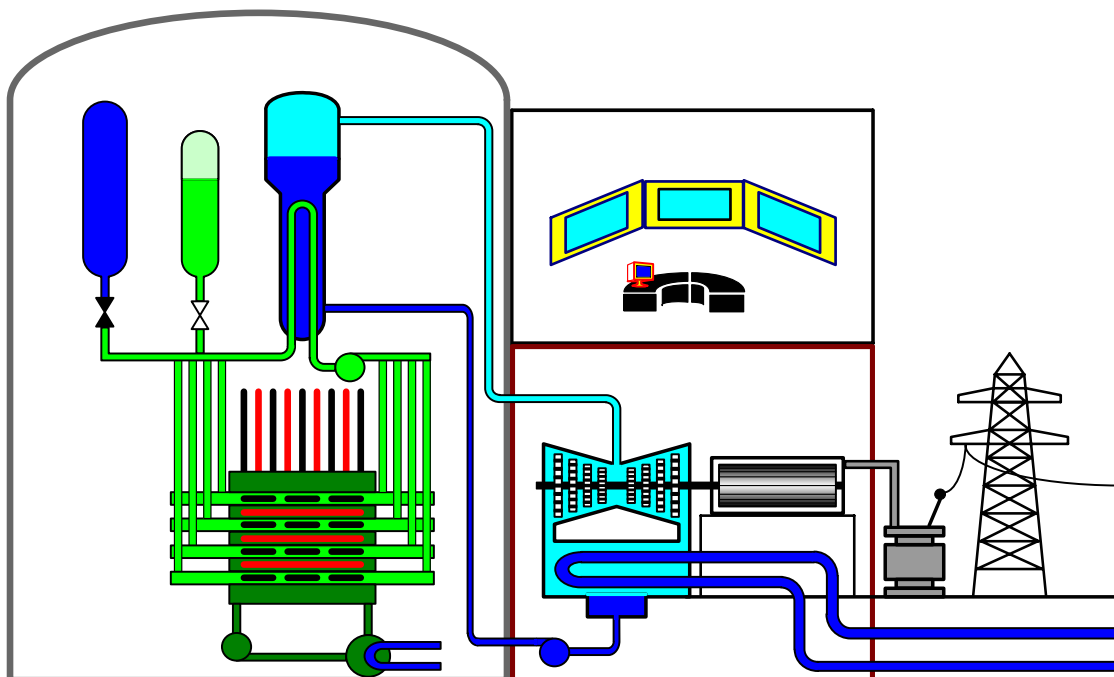

TABLE OF CONTENTS

Introduction		
1.0	Overall Unit	1-2
1.1	Energy Conversion	1-4
1.2	Water Moderated Reactors	1-8
1.3	Reactor Safety	1-8
1.4	Defense in Depth	1-11
1.5	Reactor Safety Fundamentals	1-13
1.6	CANDU Station Systems	1-15
1.7	CANDU 9 Operating Characteristics	
2.0	Reactor and Moderator	
2.1	Reactor Structure Assembly	2-2
2.2	Fuel	2-10
2.3	Moderator Systems	2-12
3.0	Reactor Control	
3.1	Reactor Control Requirements	3-2
3.2	Reactor Instrumentation	3-6
3.3	Reactivity Control Devices	3-11
3.4	Reactor Regulating System Programs	3-20
4.0	Heat Transport	
4.1	Main Heat Transport	4-2
4.2	Pressure and Inventory Control	4-8
4.3	Shutdown Cooling	4-13
4.4	Heat Transport Auxiliaries	4-15
4.5	Heat Transport System Operation	4-17
5.0	Steam, Turbine And Feedwater	
5.1	Steam Generator (Boiler)	5-3
5.2	Steam System	5-5
5.3	Turbine	5-9
5.4	Condenser	5-11
5.5	Feedwater System	5-12
5.6	Generator	5-16
5.7	Conventional Plant Services	5-18
6.0	Special Safety Systems	
6.1	Shutdown System Requirements	6-2
6.2	Shutdown System Number 1	6-7
6.3	Shutdown System Number 2	6-15
6.4	Emergency Core Cooling Systems	6-26
6.5	Containment System	6-32

Copyright © 2005 Dr. George T. Bereznai

INTRODUCTION

COURSE OBJECTIVES

At the successful completion of this course the participants will be able to:

Describe the following features of a CANDU Generating unit:

- the principles of overall unit operation and control
- the functions, equipment and operation of the main process systems
- how each major system is controlled
- how reactor safety and the protection of the public is achieved;

Conduct normal and abnormal operations on a simulated CANDU-9 Generating unit, including:

- power maneuvers
- poison override operation
- recovery from a reactor trip
- recovery from a turbine trip
- responses to reactor, heat transport, steam and feedwater system malfunctions.

This text has been prepared to support the Nuclear Power Plant Systems and Operation course, which has the following main components:

- modules in science fundamentals, equipment and systems principles relevant to CANDU reactors;
- modules in CANDU reactor power plant systems and their operation;
- self-study of this text to support the above modules;
- problem solving assignments to reinforce the understanding and application of the course material;
- operation of a CANDU-9 power plant simulator;
- reviews in a workshop or tutorial format to answer questions and exchange information on topics that are of interest to the majority of the course participants.

The traditional approach to teaching nuclear power plant design and operation has been to begin with the scientific theory and mathematical representation of the fundamental processes that take place in a nuclear power plant, studying simplified models, individual pieces of equipment, eventually combining these into systems and finally synthesizing a complete generating unit. This approach may be called 'bottom-up', since each building block must be understood before subsystems can be formed into systems and eventually into a working whole. Although this approach has been used successfully for many generations of students, it is not considered appropriate for a class of adult learners with varied experience in the nuclear power field. Such individuals will typically be experts in one or more areas relevant to nuclear power plants, but few if any will have a good understanding and experience with the overall operation of specific power plant types.

The approach followed in this text and in the course it supports is called 'top-down'. It is built on the assumptions that the participants want to achieve an overall understanding of how a nuclear power plant operates, that each of them are already familiar with many of the underlying science fundamentals, equipment and system principles of nuclear electric generation, and that each participant will want to study different aspects of nuclear power plants to different degrees. As such, while the lectures will treat topics that are necessary for everyone to achieve the desired level of common understanding, it is left to the self-study sessions for each individual to pursue various topics to different depths. The Simulation and Problem Solving sessions are designed to ensure that the desired level of understanding is achieved by every participant. Any shortcomings identified during these sessions will be addressed during the review period, and if necessary will result in changes to the content of the lectures and/or the conduct of the self-study and simulation sessions.

The sequence and content of the lectures and the assignments are designed to achieve the terminal course objectives in the most direct way, subject to the knowledge and skill level of the participants. As much as practicable, the final learning outcome of each session is to be presented first, followed by covering as much detail as is necessary for the participants to gain the desired level of knowledge. For example, if the participants are familiar with reactor theory and with light water reactors but not with the specific features of heavy water reactors, the lecturer should begin with the latter, and only cover the other topics if they are needed to understand the operation of the heavy water reactor. The subsequent assignments would include questions and problems that were designed to verify the assumed level of theoretical and light water reactor specific knowledge, and if significant shortfalls were discovered, these would be taken up in the subsequent review session and/or lecture.

ACKNOWLEDGEMENT

The material for this text is based principally on the CANDU 9 480/NU Technical Description, AECL document 69-01371-TED-001 Rev. 1, published in January 1995. Diagrams and text have also been based on various AECL and Ontario Hydro training manuals.

CHAPTER 1

OVERALL UNIT

CHAPTER OBJECTIVES:

At the end of this chapter, you will be able to describe the following for a CANDU nuclear generating station:

- 1.1 Energy conversions from fission to electricity;
- 1.2 The main functions and components of each major system;
- 1.3 How an energy balance is maintained between the reactor and the conventional side of the station;
- 1.4 How the unit as a whole is controlled;
- 1.5 The fundamentals of reactor safety;
- 1.6 The main systems and operating characteristics of a CANDU generating unit.

Nuclear generating stations exist for the purpose of converting the energy obtained from the fission of certain nuclei to electricity. This energy conversion takes place via a number of intermediate stages that require many pieces of equipment organized into several systems under the control and protection of both manual and automatic operations. This chapter presents the main features of a nuclear power plant, so that as each system is studied in greater detail in subsequent chapters and in other courses, the reader should always be able to place such detail into the overall context of an operating station.

1.1 ENERGY CONVERSION

The basic nuclear generating station energy cycle is shown in Figure 1.1. Fuel containing fissile material (Uranium) is fed to the reactor where fission takes place. The energy liberated appears in the form of heat, which is used to boil water. The steam produced from the boiling water spins a turbine-generator set, where the heat is converted first to kinetic energy in the turbine and to electricity by the generator; the electricity produced (denoted as megawatts) is supplied to the electric power system.

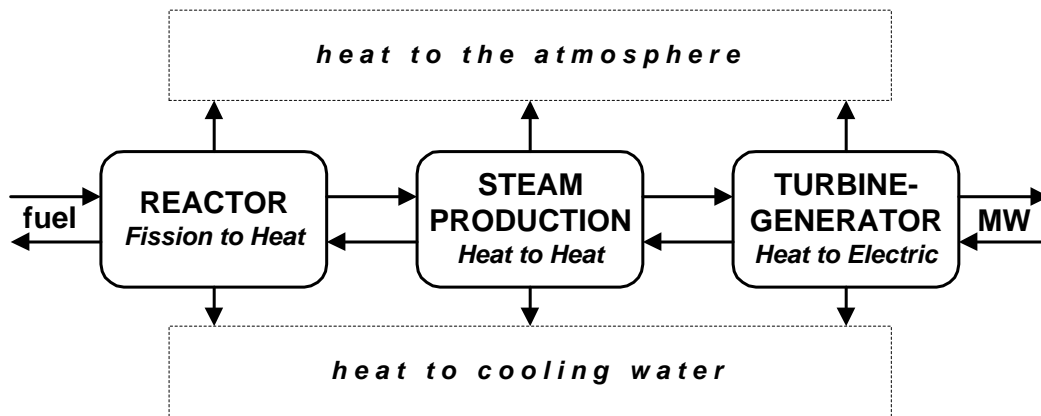

Figure 1.1. Basic flow of energy in a nuclear generating station.

It is important to recognize that while the transport of heat from the reactor to the turbine takes place in one or two closed loop systems that are highly efficient, the transformation of the heat energy of the steam to the kinetic energy of the turbine is accompanied by a large loss of energy as the steam is condensed to water prior to recirculating it back to the steam production system. Approximately 60% of the heat energy removed from the fuel is rejected to the condenser cooling water. As we will see, several other systems are also cooled by water. Under normal operations only a few % of the energy is lost directly to the atmosphere.

As indicated in Figure 1.1 spent fuel is periodically removed from the reactor. On the generator end the flow of electrical energy is shown to be in two directions to indicate the electrical energy consumption of the station itself.

This very much oversimplified representation of a nuclear generating station will become increasingly more complex as we study the details of the many systems involved directly or indirectly in the energy conversion processes, and in ensuring that these processes are always under control and are operated in a safe manner.

Energy Balance

Nuclear generating stations are designed to operate for extended periods at a constant power level, requiring that a steady state balance is maintained between the rate of energy released from the fuel in the reactor and the electrical output of the generator. This must be achieved despite inherent variations in the burn-up of fuel in the reactor, disturbances in the energy conversion processes, in the demands of the electrical power system and in the energy exchanges between the environment and the station.

As a minimum the plant control system must be able to adjust reactor power to produce the desired amount of electricity. Since under normal operating conditions the generator is synchronized to the electric power grid, the electrical energy produced by the generator is determined by the energy of the steam admitted to the turbine. A mis-match between the energy produced by the reactor and the steam energy required to produce the desired electrical output will result in a change of steam temperature and pressure. Because steam pressure measurements respond more quickly than temperature measurements, it is steam pressure that is used to indicate an imbalance of energy between reactor and generator, and is therefore the parameter chosen as an input to the control system to maintain the required balance.

A very much simplified plant control system is shown in Figure 1.2. The key inputs to the control system are:

- reactor power
- steam pressure
- generator output (MW).

The station control system is designed to keep steam pressure constant while matching the stations output to the desired setpoint. If the setpoint is the desired level of megawatts, then the control system adjusts reactor power by changing the position of the reactivity control devices, and the control system is said to be in ‘reactor lagging’ mode. If the setpoint is the desired reactor power output, then the control system adjusts the steam flow to the turbine by changing the opening of the governor valve, thereby altering the generator’s output, and the control system is said to be in ‘reactor leading’ mode. The choice of which type of setpoint to specify depends on the operating status of the generating station and the requirements of the electrical power grid, and input to the control system by the authorized station operator.

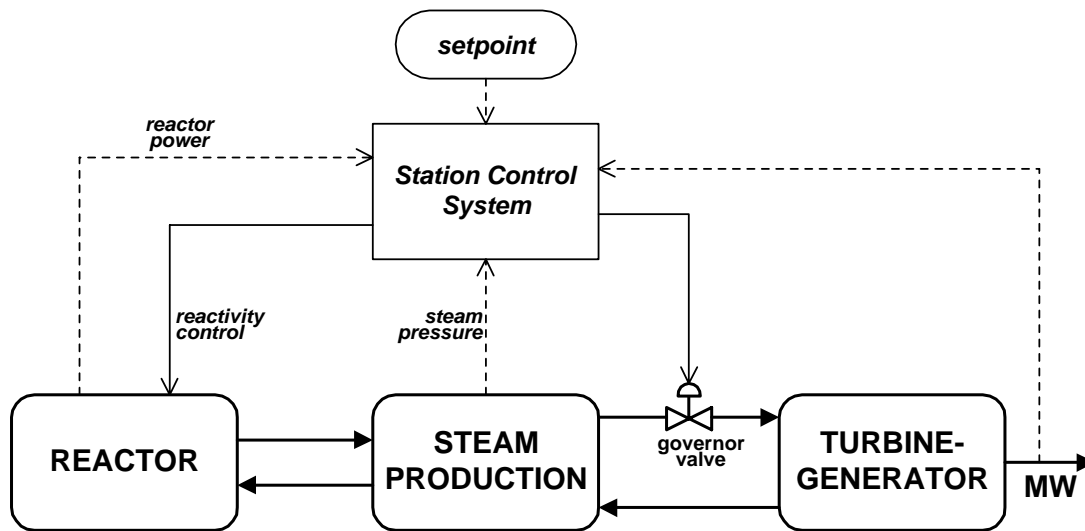
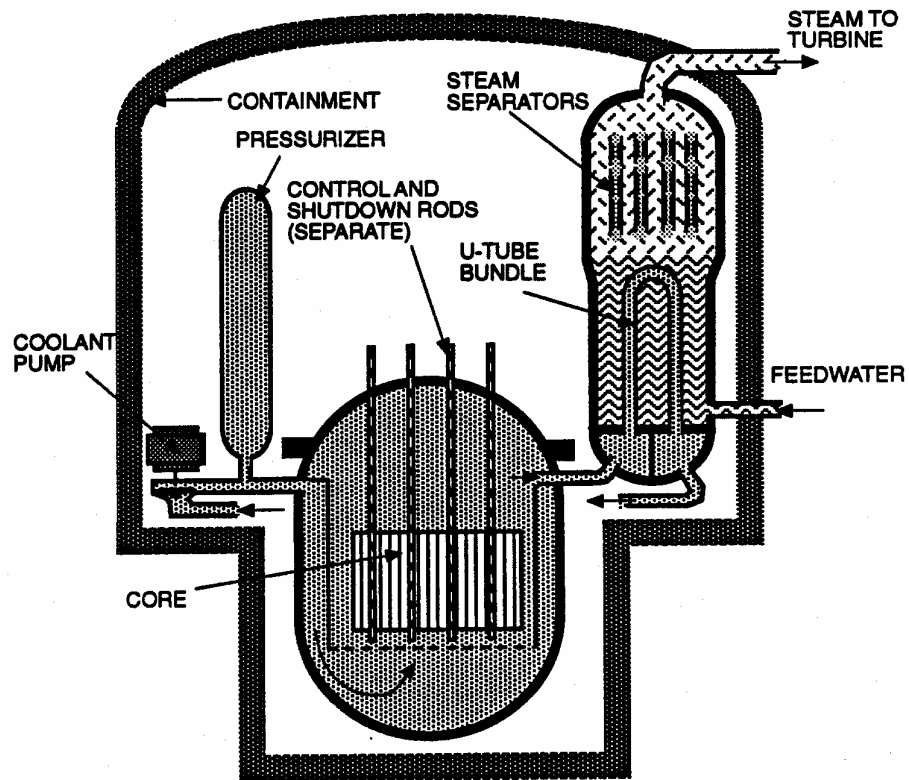

Figure 1.2. Simplified Nuclear Generating Station Control System.

1.2 WATER MODERATED REACTORS

Most of the nuclear power plants in operation around the globe use reactors that are both moderated and cooled by water. Reactors that use enriched uranium use ordinary (or light) water as both moderator and coolant. The reactor core is contained in a pressure vessel with no separation between moderator and coolant. Two main types of light water reactors have been developed, the Pressurized Water Reactor (PWR) and the Boiling Water Reactor (BWR). In the former the reactor coolant forms a closed primary loop in which it is not permitted to boil under normal operating conditions, and the steam is produced in a secondary loop. In a BWR the coolant is allowed to boil and the steam is fed directly to the turbine. The main characteristics of PWR and BWR reactors are shown in Figure 1.3 and Figure 1.4. The next two sections outline some of the main design and operating features of these types of reactors.

Reactors fueled with natural uranium must use heavy water instead of light water as the moderator, and in order to achieve maximum neutron economy, many heavy water moderated reactors also use heavy water as the coolant. The currently used designs are of the pressurized primary loop type similar to PWRs, but instead of a pressure vessel, pressure tubes contain the coolant and the fuel, while the moderator is in a low pressure, low temperature calandria vessel. Since this text deals extensively with the CANDU (CANadian Deuterium Uranium) type of pressurized heavy water reactors, the illustration of a CANDU in Figure 1.5 is provided only as a means of easy comparison with the PWR and BWR reactor types.



Moderator	H ₂ O at 15 MPa
Coolant	H ₂ O at 15 MPa
Fuel	U-235, enriched to 3-5%

Moderator and coolant are combined.
Refueled off load every 12-18 months.
Light water coolant transfers heat to boiler.

Figure 1.3. Pressurized Water Reactor.

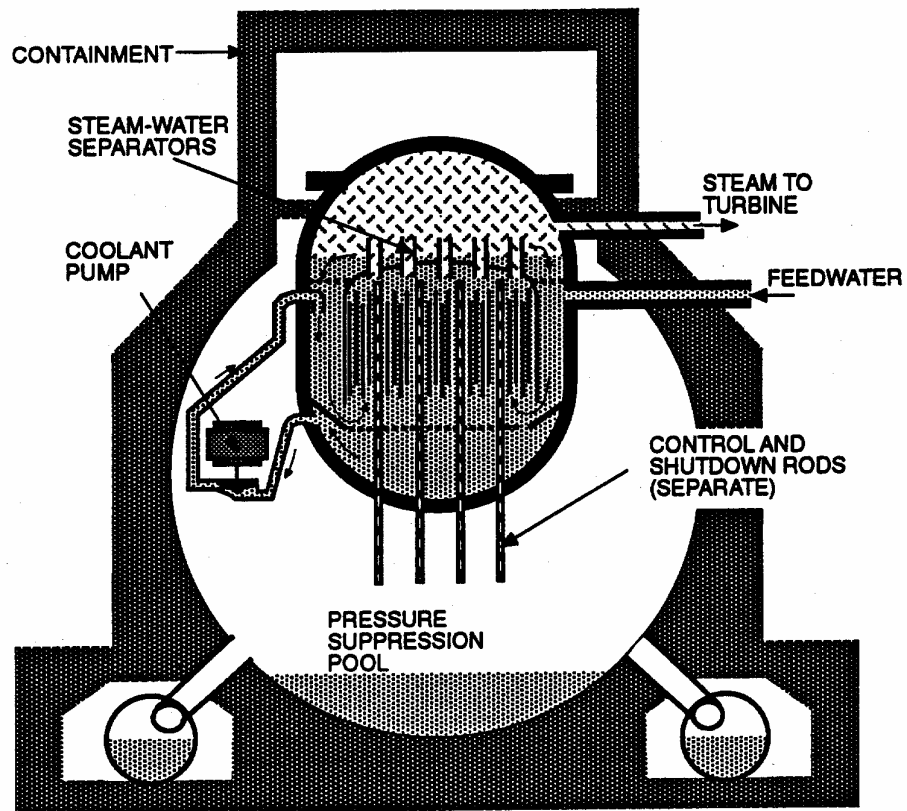

Moderator
Coolant

H₂O 6-7 MPa
H₂O, Enriched to 2-3%

Moderator and coolant are combined.
Refueled off load every 12-18 months.
Steam flows directly to the turbine.

Figure 1.4. Boiling Water Reactor.

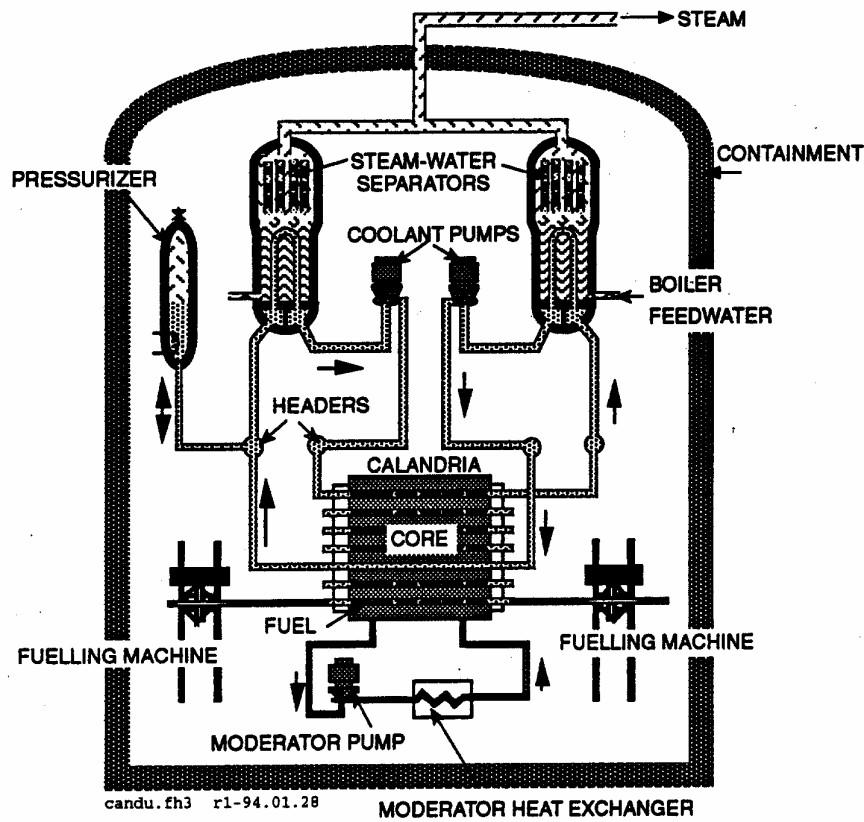

Moderator	D ₂ O at 1 atmosphere
Coolant	D ₂ O 9-10 MPa
Fuel	Natural Uranium Dioxide
Pressure tube reactor.	
Refueled while at power.	
Heavy water coolant transfers heat to boiler.	

Figure 1.5. CANDU Reactor.

1.3 REACTOR SAFETY

In order to minimize the potential threat to the public from the radioactive materials contained within a nuclear station, a number principles have been developed and incorporated into the design and operation of nuclear generating stations. Collectively, these principles have been incorporated in the golden rule of Reactor Safety, which can be stated as:

There is a minimum risk to the public and the environment from reactor fuel, provided that at all times:

- The reactor power is controlled;
- The fuel is cooled;
- The radioactivity is contained.

This rule is often shortened to CONTROL, COOL, and CONTAIN.

1.4 DEFENSE IN DEPTH

There are different ways of achieving the golden rule (CONTROL, COOL and CONTAIN). Many of these have been incorporated into an important concept known as Defense in Depth. This underlies the whole process of design, construction, commissioning, and operation of a nuclear power plant. This concept is illustrated by the five part model shown in Figure 1.6.

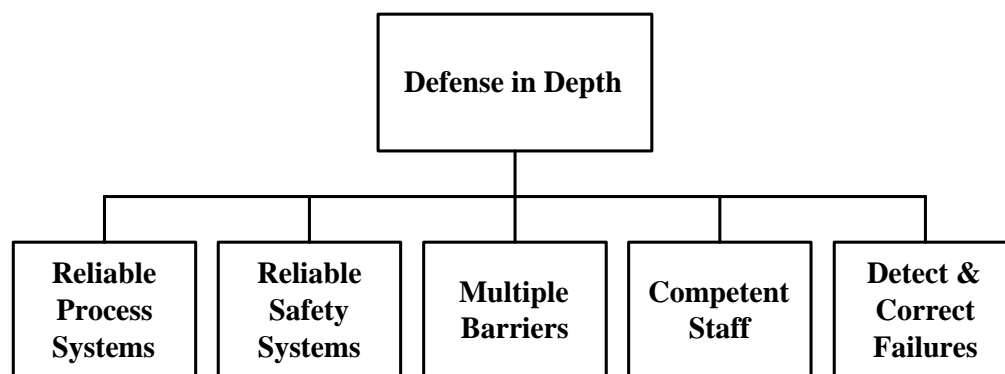

Figure 1.6. Defense in Depth Model.

The Defense in Depth concept assumes the following:

- nuclear station design will have some flaws;
 - equipment will occasionally fail;
 - operating personnel will occasionally make mistakes.
-

The key is to ensure sufficient depth of defense that flaws, failures and mistakes can be accommodated without increasing the risk or consequences of an accident. If we look at each of the major blocks of the model in turn, we can see how this is accomplished.

Reliable Process Systems

Process systems are the systems that perform a continuous function in the normal operation of the plant. For example, the primary heat transport system is a process system that is continuously active in the removal of heat from the fuel. The reactor regulating system is a process system that is continuously active in the normal control of reactor power. Reliable process systems ensure that heat is produced and electricity generated while maintaining control, cooling and containment.

Reliable Safety Systems

Safety systems are poised systems that operate only to compensate for the failure of process systems. They can do this by shutting down the reactor to regain control (shutdown systems), by providing additional cooling to the fuel (emergency core cooling system), and by containing radioactivity which has escaped from the fuel (containment system). Reliability in this context means that in the rare event these systems are called upon to act, they will be available to perform their intended function. The remaining sections of this chapter deal with these four safety systems.

Multiple Barriers

The multiple barrier approach that has been built into station design is intended to prevent or impede the release of radioactivity from the fuel to the public. There are five passive barriers (refer to Figure 5.2) that are continuously available:

- the uranium fuel is molded into ceramic fuel pellets which have a high melting point and lock in most of the fission products;
- the fuel sheath which is made of high integrity welded metal (zircaloy) and contains the ceramic fuel;
- the heat transport system which is constructed of high strength pressure tubes, piping and vessels and contains the fuel bundles;
- the system which provides a relatively leak tight envelope maintained slightly below atmospheric pressure. This partial vacuum encourages air to leak in instead of out thereby helping to prevent release of radioactivity that escapes from the heat transport system;
- the exclusion zone of at least one kilometer radius around the reactor that ensures any radioactive releases from the station are well diluted by the time they reach the boundary.

For radioactivity to reach the public from the fuel, it would have to breach each of the five barriers in succession. This provides a significant degree of protection to the general public.

Competent Operating and Maintenance Staff

The safety systems are designed to operate automatically and the five passive barriers are always in place, but the Defense in Depth concept does not allow reliance on equipment and systems to prevent accidents. It is essential that the operating and maintenance staff are knowledgeable about system conditions, alert for any evidence that systems or equipment may be on the verge of failure, and act promptly to prevent or minimize the consequences of such failures.

Detect and Correct Failures

Adequate detection and correction of failures requires not just competent staff but also processes and procedures for the staff to carry out in a systematic fashion. For example, a routine testing program for safety systems helps us meet the availability targets. An operational surveillance program in conjunction with a planned preventive maintenance program helps us to ensure that equipment and systems are monitored, inspected and repaired before they fail. Failures, when they do occur, are thoroughly investigated and solutions applied through a rigorous change approval process.

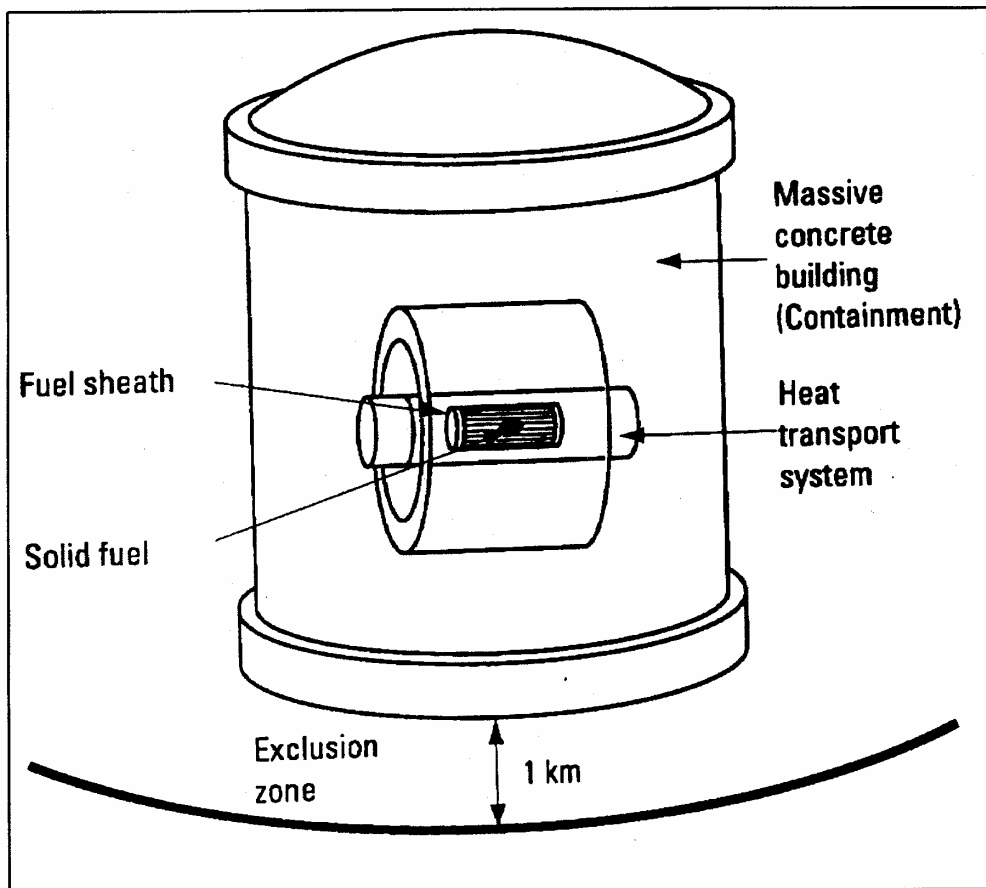

Figure 1.7. The Five Barriers to Radioactivity Release from the Fuel.

1.5 REACTOR SAFETY FUNDAMENTALS

There are special safety systems which are specifically incorporated in the plant to mitigate the consequences of a serious process failure requiring reactor shutdown, decay heat removal and/or retention of released radioactivity. Special safety systems perform no active functions in the normal operation of the plant, they are said to be 'poised' to prevent unsafe consequences of plant operation under abnormal or accident conditions. There are four special safety systems, as follows:

- shutdown system number 1,
- shutdown system number 2,
- emergency core cooling system,
- containment system.

The reactor may not be operated without all of the special safety systems being available. Systems which provide reliable services, such as electrical power, cooling water, and air supplies to the special safety systems are referred to as safety support systems.

The methods used to ensure that the safety requirements for the special safety systems are satisfied include redundancy, diversity, reliability and testability, separation, qualification, quality assurance and the use of appropriate design codes and standards. These are discussed below.

Redundancy

Redundancy is the use of two or more components or systems which are each capable of performing the necessary function. Redundancy provides protection against independent equipment failures.

Diversity

Diversity is the use of two physically or functionally different means of performing the same safety function. Diversity provides protection against certain types of common-mode failures, such as those arising from design or maintenance errors. The special safety systems use diversity where practicable in performing the same safety function. For example, the two shutdown systems use different principles of operation and are of a physically different design.

Reliability and Testability

A high reliability ensures that the chance of a serious accident is very low. The special safety systems must each meet an availability target of 1×10^{-3} . This target is used during system design and checked by a reliability calculation. It must also be demonstrated during plant operation. The design therefore provides for testing of components and systems during plant operation to confirm the calculated reliabilities.

Separation

Separation refers to the use of barriers or distance to separate components or systems performing similar safety functions, so that a failure or localized event affecting one does not affect the other. Separation provides protection against common cause effects, such as fires and missiles.

In the CANDU 9, plant systems are separated in accordance with the 'two-group separation philosophy'. This separation philosophy divides systems into two groups, each group capable of performing the essential safety functions of reactor shutdown, decay heat removal, and monitoring. The Group 1 systems include the normal power production systems as well as two of the special safety systems. The Group 2 systems are dedicated to safety. To guard against cross-linked and common-mode events and to facilitate the comprehensive seismic and environmental qualification of the Group 2 systems, the Group 1 and Group 2 systems are, to the greatest extent possible, located in separate areas.

Seismic and Environmental Qualification, and Tornado Protection

All systems, equipment and structures required to perform the functions of maintaining reactor coolant pressure boundary integrity, reactor shutdown, decay heat removal and containment following postulated accidents are seismically and environmentally qualified and protected against tornados. This includes all Group 2 systems, the special safety systems in Group 1, structures and components, the reactor building and Class 1 systems and certain safety-support systems within the Reactor Building. Qualification ensures that the system, component, or structure can withstand the effects of the design basis earthquake, environmental condition, or tornado. Qualification is achieved by testing and/or analysis.

Quality Assurance

A comprehensive quality assurance program is applied to all stages of design, manufacture, installation, construction and commissioning of safety-related systems and structures. A program of periodic inspection is provided to detect, on a sample basis, unexpected deterioration occurring during normal operation of the plant. This ensures that the integrity of safety-related systems is not degraded by an unanticipated mechanism.

Codes and Standards

In addition to meeting the safety design objectives of redundancy, diversity, reliability and testability, separation, qualification and quality assurance, the special safety systems design complies with the mandatory codes and standards.

1.6 CANDU STATION SYSTEMS

The distinguishing characteristics of Pressurized Heavy Water Reactors (PHWR) are the use of heavy water as both moderator and coolant, allowing for the use of natural uranium as fuel. The only PHWR type that has found wide commercial applications is the CANDU reactor, a Canadian design that uses high pressure tubes for the fuel and coolant, and a low pressure calandria to contain the moderator. The CANDU design will be used throughout this text to illustrate the design and operating characteristics of PHWRs.

The main CANDU process systems are shown in Figure 1.8. The pressurized heavy water of the Heat Transport System (HTS) removes the heat energy generated by the fissioning of the fuel in the reactor. Hot heavy water (300°C) enters the boilers where some of its heat is transferred to the feedwater circulated over the boiler tubes. Cooler heavy water (260°C) goes to the heat transport pumps from where it is circulated back to the reactor. The HTS is a closed loop system, pressurized at 10 MPa to get its saturation temperature about 40°C higher than the secondary side steam requirement, so that heat transfer can occur. Approximately 95% of the heat energy released in the reactor is transferred to light water in the boiler. The remaining 5% is lost, mainly to the moderator.

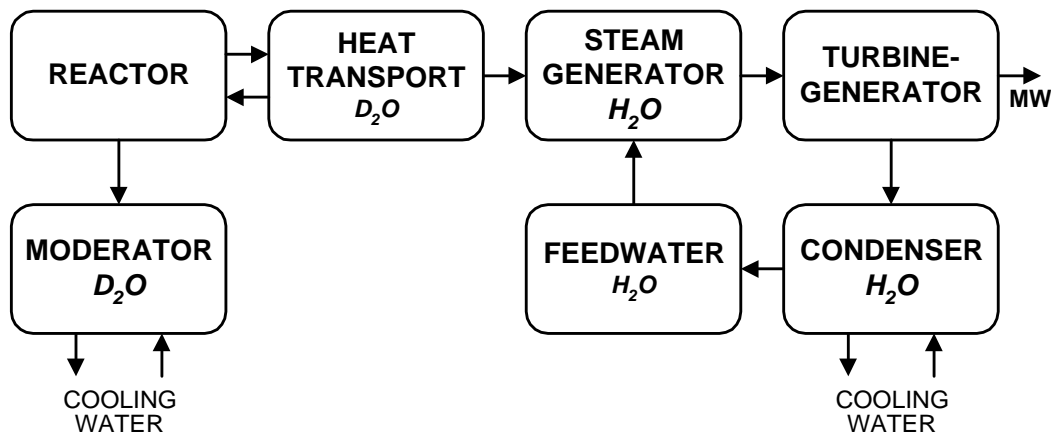

Figure 1.8. CANDU Station Main Process Systems.

In the Steam-Feedwater System the light water in the boilers is tuned to steam by the heat transferred from the Heat Transport System (HTS). The steam generated flows to the turbine where it exerts force on the turbine blades causing rotation of the turbine shaft. In the process, heat energy is converted to mechanical energy. The turbine drives the generator to produce electrical energy. The mechanical energy is converted to electrical energy and the chain of conversions is completed. The heat energy that cannot be used is given up in the process of condensing the exhaust steam to water in the condenser and the energy is transferred to the condenser cooling water. The condensate is pumped back to the boiler through different stages of feedheating as feedwater to complete the steam-feedwater cycle.

A simplified schematic of a typical CANDU unit is shown in Figure 1.9. It illustrates the location of the main process systems in the Reactor Building and the Powerhouse.

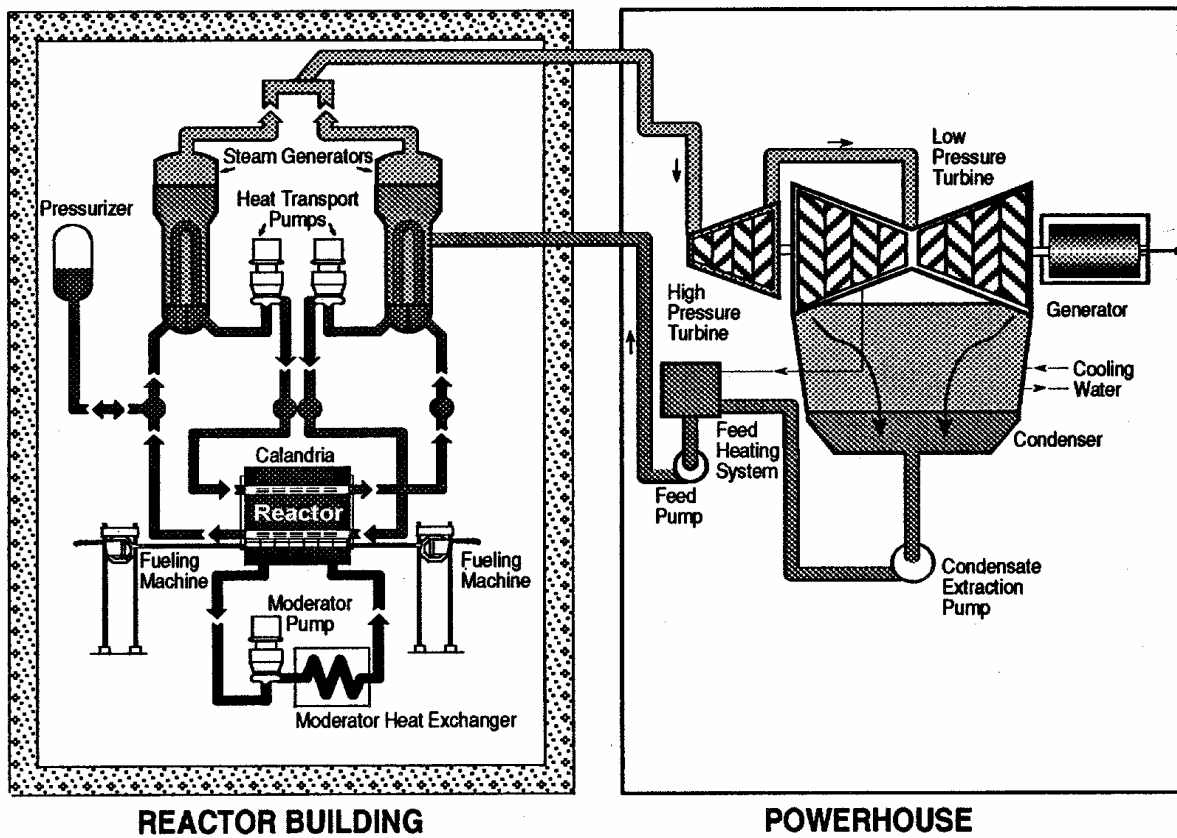

Figure 1.9. Simplified schematic and location of major systems of a typical CANDU unit.

1.7 CANDU 9 OPERATING CHARACTERISTICS

The main operating characteristics of a CANDU-9 unit are as follows:

- a. The unit is capable of sustained operation at any net electrical output of up to 100 percent of rated full power output.
- b. The overall plant control is normally of the reactor-following-turbine type.
- c. For reactor power increases, the nuclear steam plant portion of the plant is capable of maneuvering at the following rates:

Power Range	Maximum Rate
0 - 25 percent of full power	4 percent of actual power per second
25 - 80 percent of full power	1 percent of full power per second
80 - 100 percent of full power	0.15 percent of full power per second

- The overall plant power maneuvering rate is a function of turbine design, and is typically limited to 5 to 10 percent of full power per minute.
- d. During normal plant operation, assuming an initial power of 100 percent, xenon load at a steady state level, and with a normal flux shape, the reactor power may be reduced to 60 percent of full power at rates of up to 10 percent of full power per minute. The power may be held at the new lower level, indefinitely. Return to high power (98 percent) can be accomplished within four hours, or less, depending on the degree and duration of the power reduction.
 - e. In the event of a temporary or extended loss of line(s) to the grid, the unit can continue to run and supply its own power requirements.
The turbine bypass system to the condenser is capable of accepting the entire steam flow during a reactor power setback following loss of line or turbine trip, thereby avoiding any steam discharge to the atmosphere. The steam flow is initially 100 percent, but decreases to a steady state value in the range of 60 percent after several minutes.
 - f. The unit is capable of reaching 100 percent net electrical output, from a cold shutdown within 12 hours. If the pressurizer is at its normal operating temperature and pressure, the unit is capable of reaching 100 percent electrical output within seven hours (depending on Xenon level).
 - g. The reactor and turbine are controlled by computer from zero to 100 percent of full power.
 - h. Following a shutdown from sustained full power operation with equilibrium fuel, the reactor can be restarted within 35 minutes (the poison override time) and returned to full power operation, otherwise, a 'poison-out' period of about 36 hours results, during which the reactor cannot be restarted.

The gross output of the generator is 925 MW and the station service power is 55 MW, yielding a net unit electrical output of 870 MW.

The orientation of the CANDU 9 on a given site is defined by the reference directions, designated A, B, C, and D, as shown on all layout drawings and illustrations (see Figure 1.10 for example).

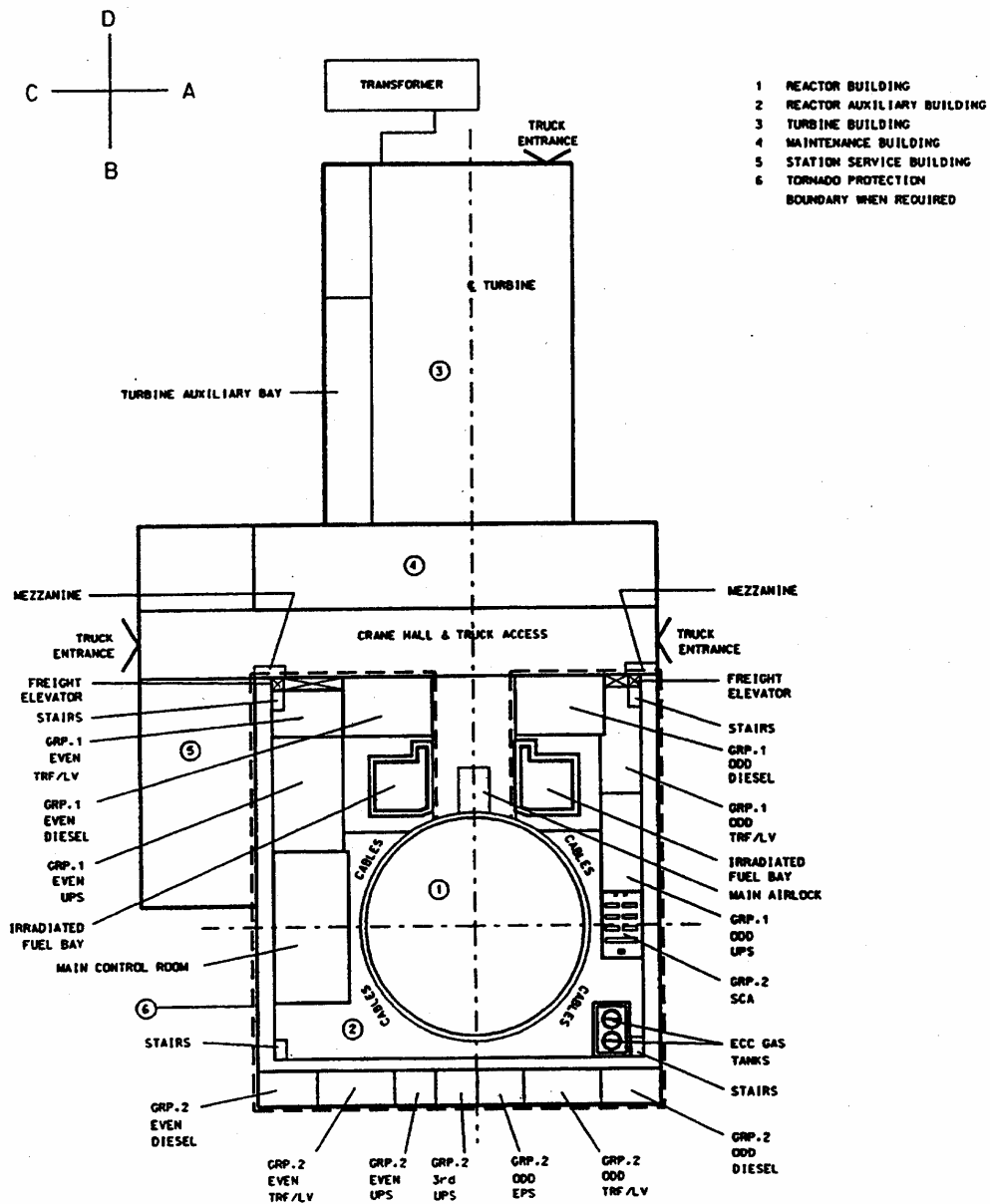

Figure 1.10. CANDU 9 Single Unit Station Layout.

Two Group Layout of Plant Systems

All plant systems are assigned to one of two groups (Group 1 or Group 2); each group is capable of shutting the reactor down, cooling the fuel, and of providing plant monitoring. In general, Group 1 systems sustain normal plant operation and power production and include two special safety systems while Group 2 systems have a safety or safety support function. Group 1 and Group 2 services are accommodated in physically separate areas of the station to the extent feasible. All Group 2 services, except for the Group 2 raw service water system, are totally accommodated within the Group 2 portion of the reactor auxiliary building and to the extent practical are physically separated from the Group 1 areas. Group 2 structures and all equipment within them are seismically qualified, and protected against severe external events such as tornado.

Group 1 services are housed in the Group 1 areas of the reactor auxiliary building and in a portion of the turbine building auxiliary bay. The Group 1 areas of the reactor auxiliary building are seismically and environmentally qualified. The Group 1 services portion of the turbine building auxiliary bay is environmentally sealed to prevent steam ingress in the event of a steam line break occurring in the turbine building. The main steam safety valves must be seismically qualified and protected from severe external events.

The main control room, located in the reactor auxiliary building, is seismically qualified and environmentally protected to protect the operator from all design basis events. A secure route is provided allowing the operator to move from the main control room to the secondary control area, located in the Group 2 area of the reactor auxiliary building, following an event which causes a loss of operability or habitability of the main control room.

Reactor

The position of the reactor in the reactor vault is shown in Figures 1.11 and 1.12. The arrangement of the reactor is shown in Figure 2.3. The cylindrical calandria and end shield assembly is enclosed and supported by the cylindrical shield tank and its end walls. The calandria contains heavy water moderator and reflector; the shield tank contains light water. The heavy water moderator system is independent from the pressurized heavy water heat transport coolant in the fuel channel pressure tubes.

The lattice sites, arranged parallel to the horizontal axis, pass through the calandria. Each of the lattice sites accommodates a fuel channel assembly. Each fuel channel assembly consists of a zirconium-niobium alloy pressure tube, centralized in a calandria tube, and expanded into stainless steel end fittings at both ends. The annulus between the pressure tube and the calandria tube is maintained by annular spacers and is gas-filled to provide thermal insulation. Each of the fuel channel assemblies contains 12 fuel bundles.

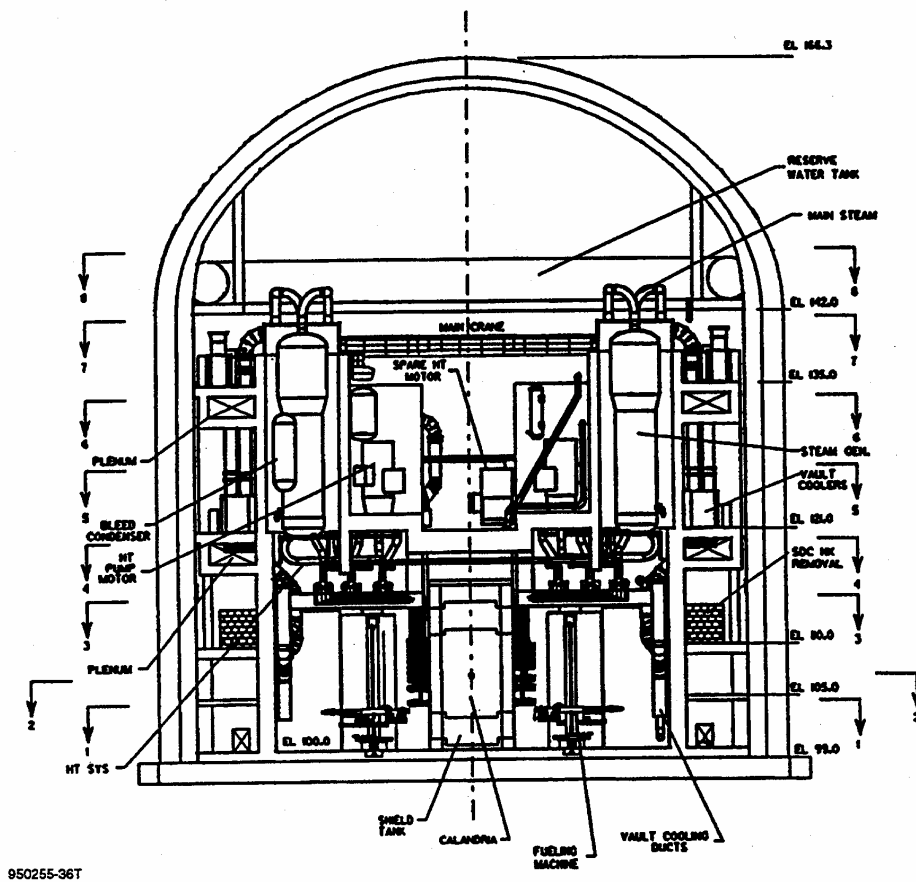

Figure 1.11. Reactor Building Section 7-7.

The calandria shell is closed and supported by the end shields at each end. Each end shield is comprised of an inner and outer tubesheet joined by lattice tubes and a peripheral shell. The spaces between the inner and outer tubesheets of both end shields are filled with steel balls and water, and are water-cooled. This shielding allows personnel access to the reactor face during reactor shutdown.

The end shields are connected to the end walls of the shield tank assembly which are, in turn, supported from the vault floor by the reactor vault walls. The space between the calandria shell and the shield tank shell is filled with light water, which serves as a thermal and a biological shield. This shielding allows personnel access to the reactor vault during reactor shutdown.

The vertical and horizontal reactivity control units are installed from the top and from the sides of the calandria, respectively, between and perpendicular to the calandria tubes. The vertical and horizontal reactivity control units enter the calandria from the reactivity mechanisms deck and from the shield tank side walls, respectively.

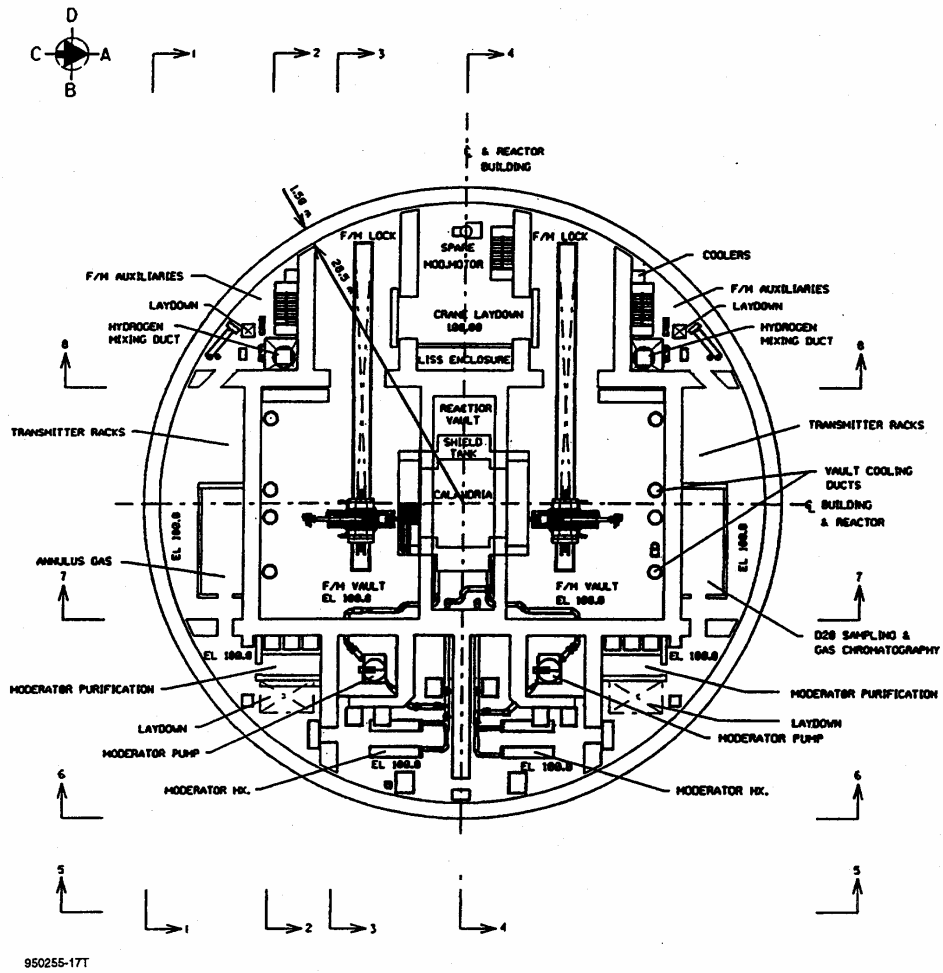

Figure 1.12. Reactor Building Plan El. 100.00.

Moderator Systems

The heavy water moderator in the calandria is used to moderate the fast neutrons produced by fission and is circulated through the calandria and moderator heat exchangers to remove the heat generated in the moderator during reactor operation. The location of the inlet and outlet nozzles high on the sides of the calandria ensures uniform moderator temperature distribution inside the calandria. The moderator free surface is near the top of the calandria. The operating pressure at the moderator free surface is the normal cover gas system pressure.

The moderator system consists of two interconnected circuits, each containing a heat exchanger and a circulation pump.

The moderator auxiliary systems include the moderator D₂O collection system, the moderator D₂O sampling system, the moderator liquid poison system, the moderator purification system, and the moderator cover gas system.

Heat Transport Systems

The heat transport system is a single loop with a figure of eight coolant flow pattern. The equipment arrangement with the steam generators and pumps 'in-line' at each end of the reactor results in bi-directional flow through the core (Figure 1.13). The four steam generators are of the vertical U-tube type with an integral preheating section. The four heat transport system pumps are vertical single discharge, electric motor driven, centrifugal pumps with multi-stage mechanical shaft seals.

No chemicals are added to the heat transport system for reactivity control. The heat transport auxiliary systems include the heat transport purification system, the pressure and inventory control system, the shutdown cooling system, the heat transport collection system and the heat transport sampling system.

Fuel

The CANDU 9 uses the same 37-element fuel bundle design as the other operating CANDU reactors. Each fuel element contains sintered pellets of uranium dioxide with a U²³⁵ content of 0.71 wt% in a Zircaloy-4 sheath. There is a graphite layer (CANLUB) on the inside surface of the sheath. End caps are resistance welded to the ends of the sheaths to seal the element. End plates are resistance welded to the end caps to hold the elements in a bundle assembly. Spacer pads are brazed to the elements at their midpoints, to provide inter-element spacing. Element contact with the pressure tube is prevented by bearing pads brazed near the ends and at the mid-point of each outer element. Beryllium metal is alloyed with the Zircaloy-4 to make the braze joints.

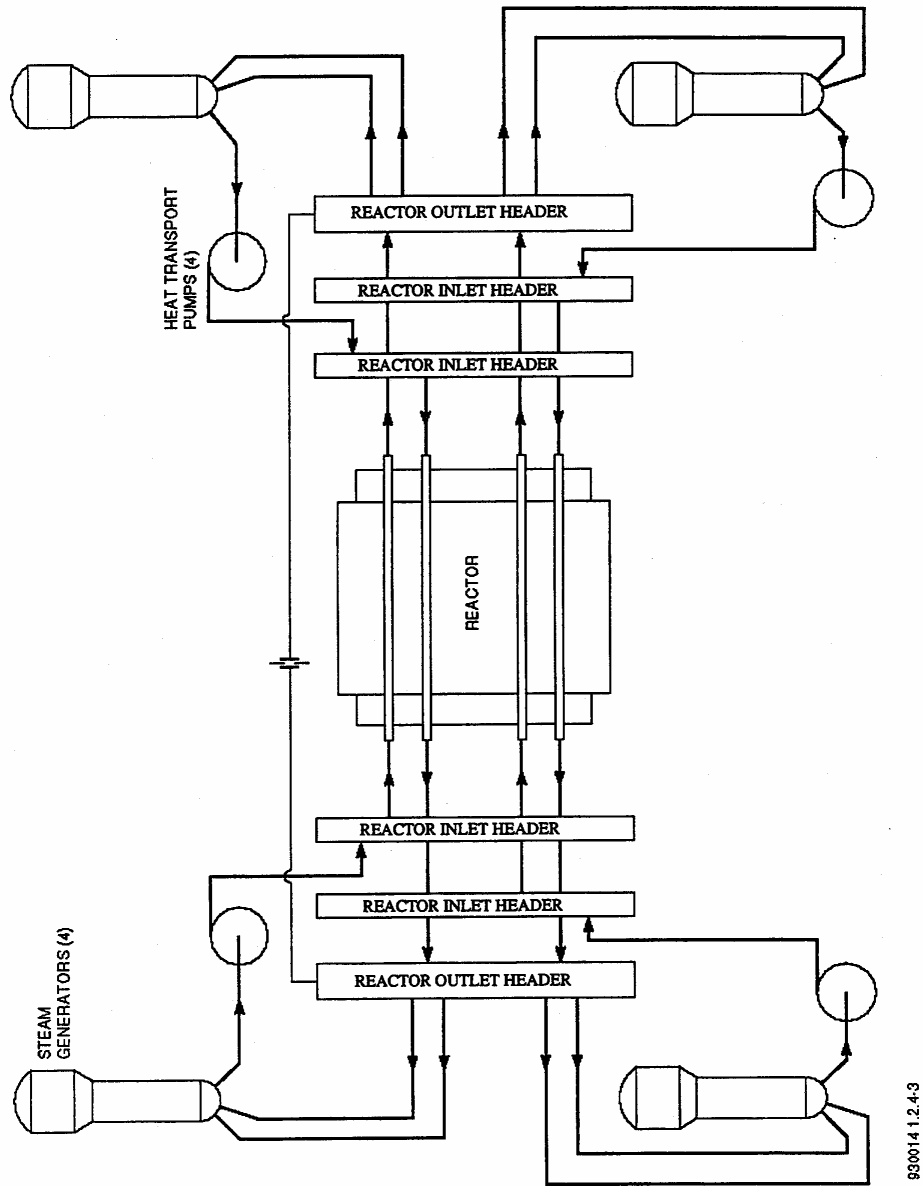

Figure 1.13. Heat Transport System Simplified Flow Diagram.

Fuel Handling

To use natural uranium fuel economically, it is necessary to introduce new fuel and remove irradiated fuel (spent fuel) in a continuous manner. The pressure tube design is convenient for on-power refueling. The fuel inside the individual pressure tubes can be changed using remotely controlled fuelling machines one channel at a time.

The CANDU 9 is refueled on-power using two fuelling machines located at opposite ends of the reactor. The fuelling machines are operated from the main control room. For refueling, the fuelling machines are positioned at opposite ends of the fuel channel to be refueled, and locked on to the end fittings to obtain leak-tight joints.

After the fuelling machines are aligned and clamped to the channel, the pressures in the machines and channel are equalized. The fuelling machines then remove the channel closures, guide sleeves are installed and injection flows are established from the fuelling machines. The shield plugs are then removed which allows the fuelling machine at the inlet end of the channel to move the fuel string towards the fuelling machine located at the outlet end. A ram adapter is added to the fuelling machine ram. The irradiated fuel bundles are supported with this ram adapter as they are pushed, separated into pairs and stored in the fuelling machine. During refueling, the irradiated fuel bundles are removed from the fuel channel outlet and new fuel bundles added at the inlet.

The fuel management scheme dictates which irradiated bundles are sent to the irradiated fuel storage bay, and the arrangement of the fuel bundles (including both irradiated bundles and new fuel bundles) in the fuel channel after refueling.

The reverse sequence of returning shield plugs, removal of guide sleeves and re-installation of the channel closures completes the refueling sequence on channel.

The fuelling machine unloads irradiated fuel bundles through the associated irradiated fuel port which leads to one of the irradiated fuel storage bays located outside the reactor building containment wall. The irradiated fuel storage bays have a storage capacity for six years of reactor operation, plus a reactor load of fuel. Lifting facilities are provided for the handling and shipping of the irradiated fuel.

The fuelling machines, the fuel transfer ports and the irradiated fuel discharge equipment are operated remotely and automatically from the main control room. Personnel access to the reactor building is required for in-situ maintenance of the fuel handling equipment. The fuelling machines are removed from the reactor building for all major maintenance.

Reactor Power Control

Total reactor power is controlled automatically by computer from zero power to full power. Liquid zone control compartments, distributed throughout the reactor core in vertical zone control units, provide the primary means to regulate reactivity during normal reactor operation. The zone control units adjust the flux level in any of the reactor zones by adding or removing light water to/from the zone control compartment to provide local control of neutron absorption.

The semi-continuous on-power refueling system provides the principal means of long term reactivity control. In addition to the zone control system, adjuster rods, mechanical control absorbers, and the addition of soluble poison to the low temperature moderator are other means available for reactivity control.

The reactor regulating system allows the reactor power to be reduced to about 60 percent of full power and operation continued indefinitely at that level or to be quickly reduced to zero power and then restarted within 35 minutes (which is the xenon override time). Steam discharge to the turbine condenser allows continued reactor operation at reduced power when the turbine or electrical grid connection is not available.

Instrumentation and Control

Most of the plant systems used for normal power production and fuel handling, i.e., the Group 1 systems, are monitored and controlled by a distributed digital computer control system. This system includes a Plant Display System to provide the primary operator interface in the main control room. Redundant channelized sensors and actuators are used for important functions.

Separate, independent, and diverse instrumentation and control systems are used for the special safety systems and Group 2 safety support systems. Separate independent operator interface equipment is provided in the secondary control area to perform all necessary safety functions in the event that the main control room becomes uninhabitable.

Reactor Safety

Safety related systems perform the safety functions necessary to maintain the plant in a safe condition during normal operation, and to mitigate events caused by the failure of the normally operating systems or by naturally occurring phenomena (e.g. earthquakes). The safety related systems used for mitigating events include four special safety systems and safety support systems which provide necessary services to the former. The four Special Safety Systems are: Shutdown System Number 1 (SDS1), Shutdown System Number 2 (SDS2), Emergency Core Cooling (ECC), and Containment.

Safety related systems are separated into two groups, Group 1 and Group 2, to provide protection against common cause events which impair a number of systems or damage a localized area of the plant (e.g. fires). Group 1 includes most of the systems required for normal operation of the plant as well as two special safety systems. Systems in each group are capable of performing the essential safety functions of reactor shutdown, decay heat removal, and control and monitoring. Each group contains safety support services (e.g. electrical power systems with diesel generators, cooling water systems, and steam generator feedwater systems), which can also provide backup support services to the other group, as required. During normal plant operation, the Group 1 systems generally provide the support services to the systems in both groups.

The systems in each group are designed to be as independent from each other as practicable, to prevent common cause events from affecting systems in both groups.

Interconnections between groups are kept to a practical minimum, and provided with suitable isolation devices. Inside the reactor building, components of each group are physically separated by distance or local barriers. Outside the reactor building, the physical interface between groups is designed as a fire barrier, and as a barrier against any flooding that can occur in either of the groups. Fire barriers, flood control, and physical separation of selected components are also provided where necessary within each group.

The special safety systems are assigned to groups to provide maximum independence between those that have similar or complementary safety functions. SDS1 and the containment system are assigned to Group 1, and SDS2 and ECC are assigned to Group 2. This grouping assignment minimizes physical and functional cross connections between groups.

Most design basis events are controlled and monitored from the main control room, in Group 1. Following an event which causes loss of the operability or habitability of the main control room, the operator can control and monitor the plant from the secondary control area in Group 2.

Shutdown Systems

Two shutdown systems, additional to the regulating system, are provided to shut the reactor down for safety reasons. One system (SDS1) consists of mechanical shutdown rods while the other (SDS2) injects a gadolinium nitrate solution into the moderator via liquid poison injection nozzles. These two safety systems are independent and diverse in concept and are separated both physically and in a control sense to the maximum practical degree from each other and from the reactor regulating system. The two shutdown systems respond automatically to both neutronic and process signals. Either shutdown system, acting on its own, is capable of shutting down the reactor and maintaining it shut down for all design basis events.

Emergency Core Cooling System

The purpose of the emergency core cooling system is to replenish the reactor coolant and to assure cooling of the reactor fuel in the unlikely event of a loss-of-coolant accident. Emergency core cooling is provided by injecting light water into the reactor headers.

During the initial injection phase, air from the emergency core cooling system gas tanks is utilized to pressurize the emergency core cooling system water tanks and deliver light water to the headers at high pressure. In the long term the emergency core cooling system recirculates water through the reactor and dedicated heat exchangers for decay heat removal. Make-up water is provided from the reserve water tank.

The emergency core cooling system, except for the gas tanks and recovery pumps, is housed within the reactor building.

Containment System

The containment system consists of the containment envelope and the containment isolation.

The containment envelope is a pressure-retaining boundary consisting of the reactor building and metal extensions such as airlocks, piping system penetrations and electrical penetration assemblies. The containment envelope is designed to withstand the maximum pressure which could occur following the largest postulated loss-of-coolant accident. Piping systems passing through the envelope are equipped with isolation valves.

The containment isolation system automatically closes all reactor building penetrations open to the containment atmosphere when an increase in containment pressure or radioactivity level is detected.

A long-term containment atmosphere heat sink is provided by the reactor building air coolers.

Main Steam and Feedwater Systems

Four identical steam generators with integral preheaters transfer heat from the heavy water reactor coolant of the primary heat transport system side to the light water on the secondary side. The temperature of the incoming feedwater is increased to the boiling point and subsequently evaporated. The steam generators consist of an inverted vertical U-tube bundle installed in a shell. Steam separating equipment is housed in the steam drum at the upper end of the shell. The steam from the boilers is fed by separate steam mains to the turbine steam chest via the turbine stop valves, and its flow is controlled by the governor valves.

The steam pressure is normally controlled at a constant value by varying reactor power to match the turbine-generator demand. The condenser steam discharge valves, in combination with the atmospheric steam discharge valves, are sufficient to avoid lifting of the main steam safety valves following a loss of line or a turbine trip and, hence, permit continuation of reactor operation.

Main steam safety valves are provided on each steam main to protect the steam system and the steam generators from overpressure.

The feedwater system supplies normal feedwater to the steam generators. The feedwater system comprises the main feedwater pumps on Class IV power and a diesel-driven auxiliary feedwater pump. The feedwater is demineralized and preheated light water. The feedwater lines run from the feedwater regulating valve station in the turbine building to the reactor building and hence, to each steam generator.

The Group 2 feedwater system supplies feedwater to the steam generators at full operating pressure in the event that the main (Group 1) feedwater system is unavailable. A further backup supply is available from the reserve water tank.

Steam Generator Pressure Control

The steam generator pressure control system enables the reactor power output to track the turbine power output, using the steam generator pressure as the controlled variable. The steam generator pressure controller is a part of the overall plant control system.

During normal operation, steam pressure is primarily controlled by adjusting reactor power. If for some reason the reactor regulating system does not allow the reactor to respond to pressure controller demands, or if a reactor power reduction occurs because of a trip, a stepback, or a setback, the reactor setpoint is controlled directly by the respective reduction signal, and the 'normal' mode of control of steam generator secondary side pressure is interrupted. Steam pressure control switches to the 'alternate' mode of adjusting the plant loads. Similarly, if the operator elects to control the reactor power set point manually, steam pressure control is via plant loads.

When the plant is in the 'normal' mode, the turbine governor valves are controlled through the unit power regulator program; i.e., the unit power regulator calculates what the valve setpoint should be and pulses to that position.

If the plant is in the 'alternate' mode, the steam generator pressure control system controls the turbine in response to the steam pressure error, steam pressure error rate of change, and the rate of change of reactor power.

The turbine has a low steam pressure unloader external to the control computers. This overrides directly the turbine governor action including the steam generator pressure control signal, and causes a fast runback of the turbine.

Atmospheric Steam Discharge Valves are low capacity valves that are used to control steam generator pressure via the steam pressure control program. They are opened in proportion to the pressure error, normally with an offset in the steam pressure setpoint. These valves may also be used to provide a heat sink during shutdown for decay heat removal when the main condenser is unavailable.

Condenser Steam Discharge Valves are capable of discharging up to 70% of full power live steam to the condenser on loss of turbine so that the reactor can continue to operate at the power required to prevent a 'poison-out'. They are also used to discharge steam on a loss of line, or on a turbine trip, so that the main steam safety valves do not lift. During normal operation these valves operate on the pressure control mode, with an offset to bias them closed. During 'poison-prevent', their steady state opening is proportional to the power mismatch between the poison-prevent reactor power level and actual turbine steam consumption. On a turbine trip, they are first opened fully and then returned to the pressure control mode. During reactor shutdown they provide a heat sink through the condenser for decay heat removal.

Steam Generator Level Control

The level in each of the steam generators is controlled individually, as a function of power.

Because of safety, range of control and maintenance considerations, each steam generator has a set of three control valves for feedwater control connected in parallel: one small valve to control feedwater during shutdown, startup, and low power operation, and two larger valves to control feedwater for on-power conditions. Each of the two large valves can handle the full power flow requirements. Isolating valves are provided for each control valve.

The steam generator level control system balances feedwater to steam flow for all operating conditions: fast reactor runup, reactor setback, turbine trip and 'poison-prevent' mode. The water level setpoint is automatically programmed over a set range as a function of load. Control is by the distributed computer control system.

Turbine-Generator and Auxiliaries

The CANDU 9 turbine assembly consists of one double flow high pressure cylinder and three double flow low pressure cylinders with reheaters between the high and low pressure cylinders.

The condenser consists of three separate shells, one for each low pressure turbine cylinder.

The extraction steam system supplies five stages of feedwater heating. The low pressure regenerative feedwater heating system consists of a single bank of low pressure closed feedwater heaters and a deaerator, whereas the high pressure system consists of a high pressure heater. The deaerator is heated with extraction steam or, if unavailable, with pepping steam from the steam mains.

The Group 1 feedwater system includes three 50 percent capacity electrically driven main feedwater pumps that take suction from the deaerator storage tank and an auxiliary feedwater pump, which is diesel driven.

Electric Power System

The electric power system generates and transmits electric power to the grid and to the unit loads. Unit service power (normal) is provided by one of the two 100 percent capacity transformers, the unit service transformer or the system service transformer, from either the turbine-generator or the grid respectively. This power is distributed and further stepped down in voltage as required. Auxiliary power to equipment is provided by the Group 1 standby diesel-electric generators to all station loads which must be re-energized within a short time after the loss of the normal supply, and by seismically qualified diesel-electric generators for the Group 2 loads.

Essential control, instrumentation and safety systems equipment are supplied with uninterruptible power, through inverters, fed from a bank of batteries, backed up by the standby power buses.

Heating, Ventilation and Air Conditioning Systems

The following systems are included under this heading:

- a. The reactor building cooling system controls air temperatures in both the accessible and inaccessible areas of the building. The system consists of vault cooling units and local cooling units appropriately located within the building.
- b. The reactor building ventilation system provides air exchange, maintains the reactor building at a pressure slightly below atmospheric and provides filtration of air before exhaust to the atmosphere.
- c. The reactor auxiliary building heating, ventilation, air conditioning and clean air discharge systems.

Computerized Station Control Systems

Because of the complex interdependence of control systems in a CANDU unit, all major control functions are performed by Digital Control Computers (DCC). The main programs are:

- Reactor Regulating System (RRS)
 - Boiler Pressure Control (BPC)
 - Unit Power Regulator (UPR)
 - Boiler Level Control (BLC)
 - Heat Transport System Pressure and Inventory Control (HTSP)
-

Table 1.1 summarizes these programs with the parameters measured and the different variables controlled and manipulated. A simplified general layout of the station control system is illustrated in Figure 1.14.

Table 1.1

Program Name	Measured Parameter (s)	Variable(s) Controlled	Variable(s) Manipulated
RRS	<ul style="list-style-type: none"> Reactor Bulk Power 	<ul style="list-style-type: none"> Neutron flux 	<ul style="list-style-type: none"> Zone water level Rod Position
BPC	<ul style="list-style-type: none"> Boiler pressure Reactor power Steam Flow 	<ul style="list-style-type: none"> Boiler pressure 	<ul style="list-style-type: none"> Reactor setpoint Steam flow
UPR	<ul style="list-style-type: none"> Electrical output 	<ul style="list-style-type: none"> Electrical Output Steam Flow 	<ul style="list-style-type: none"> Steam flow
BLC	<ul style="list-style-type: none"> Boiler level Reactor power Feedwater flow Steam flow 	<ul style="list-style-type: none"> Level (Inventory) 	<ul style="list-style-type: none"> Feedwater flow
HTSP	<ul style="list-style-type: none"> HTS Pressure 	<ul style="list-style-type: none"> D₂O Pressure Pressurizer Level (where applicable) 	<ul style="list-style-type: none"> D₂O Feed & Bleed pressurizer steam bleed & heaters

Reactor Regulating System (RRS)

This program adjusts the reactivity control devices to maintain reactor power at the desired setpoint and, when required, to maneuver the reactor power level between set limits at specific rates. It also monitors and controls power distribution within the reactor core, to optimize fuel bundle and fuel channel power within their design specification. The reactivity control devices include:

- liquid zones,
- control absorbers,
- adjusters.

Boiler Pressure Control (BPC)

This program controls boiler pressure to a constant setpoint, by changing reactor setpoint (reactor lagging mode), or adjusting the turbine load (reactor leading mode). BPC can open the steam reject valves if boiler pressure is higher than desired. If BPC cannot prevent high boiler pressure by adjusting either steam flow or by adjusting reactor power, the boiler pressure is reduced by steam reject valves.

Unit Power Regulation (UPR)

This program maneuvers the unit power in the reactor lagging mode, by adjusting the turbine load setpoint, to maintain the generator output at the level demanded by the local operator, or a remote control center. In reactor leading mode UPR has only a monitoring function and takes no active part in control.

Boiler Level Control (BLC)

BLC is used to control the water level in each boiler under all unit power conditions from 0% to 100% full power. This program controls the feedwater valves to maintain the water level in the boiler sufficient for the reactor power level setpoint.

Heat Transport System Pressure and Inventory Control (HTSP)

This program controls the heat transport pressure control system to maintain heat transport pressure at a fixed setpoint. In stations with a pressurizer, pressurizer level is also controlled.

There are many other control programs in a nuclear power plant, but the ones listed above are the programs required for overall unit control.

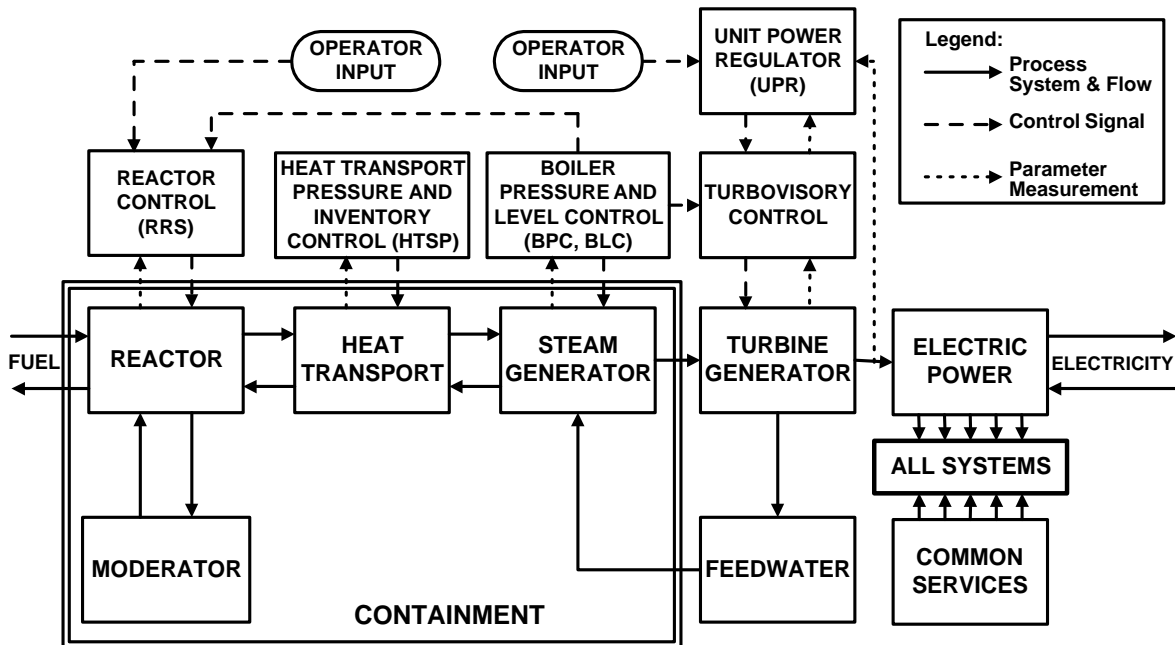

Figure 1.14. Simplified Overall Unit Control Block Diagram.

Operator/Computer Interface

As indicated earlier, digital computers are used to perform most of the control and monitoring functions of a CANDU station and replace much of the conventional panel instrumentation in the control room.

A number of man-machine communication stations, each essentially comprising a keyboard and color CRT monitors, are located on the main control room panels. The displays provided include graphic trends, bar charts, status displays, pictorial displays and historical trends.

The Unit Control Computer System was not designed to be a stand alone master brain that could handle all possible situations without intervention of an operator. Major set points, like the unit operating level, are input by the operator according to approved station procedures. Manual controls are also incorporated into the system to allow the operator to intervene under prescribed conditions, such as during major upsets, equipment failure or computer malfunction.

The operator interface was designed to provide two way communications between the operator and the computer system. The computer provides sufficient information in an appropriate form (easily understandable, meaningful, correct) to the operator to assist in decision making. The computer provides information about field processes, equipment operation, abnormal conditions, computer malfunctions, etc., in the form of displays on the monitor, alarms, or printed logs. The operator can enter information, requests, or instructions to the computer using keyboards and switches. Figure 1.15 shows a typical computer control process.

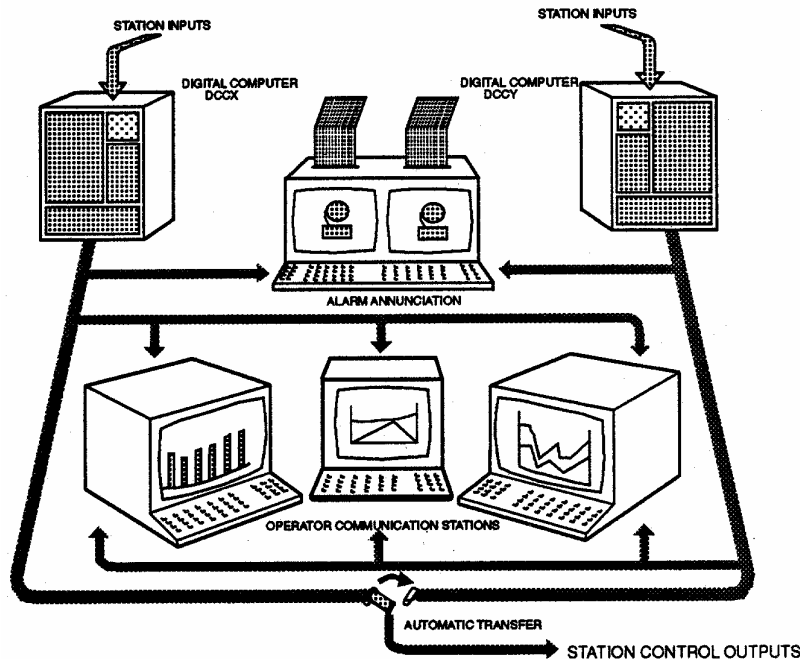

Figure 1.15. Man-machine interface and process computer control system.

Copyright information for Chapter 1:

Figures on pages 1-5, 1-6, 1-7, 1-10, 1-14 and 1-31 are from unpublished training documents of Ontario Hydro. Reprinted with permission.

Figures on pages 1-16, 1-18, 1-19 and 1-21 are from CANDU® 9 480/NU Technical Description, AECL document 69-01371-TED-001 Rev. 1, January 1995. Reprinted with permission of Atomic Energy of Canada Limited (AECL).

CHAPTER 2

REACTOR AND MODERATOR

CHAPTER OBJECTIVES:

At the end of this chapter, you will be able to describe the following features of the CANDU reactor and moderator systems:

1. The reasons for the choice of calandria and pressure tube design;
2. The functions, structures, materials and physical properties of fuel, fuel channel, coolant and moderator;
3. The main functions and heat sources of the main moderator system;
4. The equipment and operation of the main moderator system;
5. The functions and main operating characteristics of the auxiliary moderator systems.

This chapter discusses the main process systems, equipment and materials used to create and sustain a nuclear fission chain reaction. Since the heavy water moderator is essential to achieve fission using natural uranium, the reactor and moderator systems are both discussed in this chapter.

Figure 2.1 shows in simplified form the principle characteristics of the CANDU type of pressurized heavy water reactor: a large, cylindrical calandria that contains the moderator at slightly above atmospheric pressure, fuel channel assemblies each of which consists of a calandria tube, a pressure tube and fuel bundles. The pressure tubes are part of the heavy water primary heat transport system that is under sufficiently high pressure (in the order of 10 MPa) to limit the boiling of the coolant under normal operating conditions to at most 4%. The heat transport system continuously removes the heat generated in the fuel bundles and the pressure tubes, while the moderator cooling system removes the heat generated in the moderator and the calandria tubes.

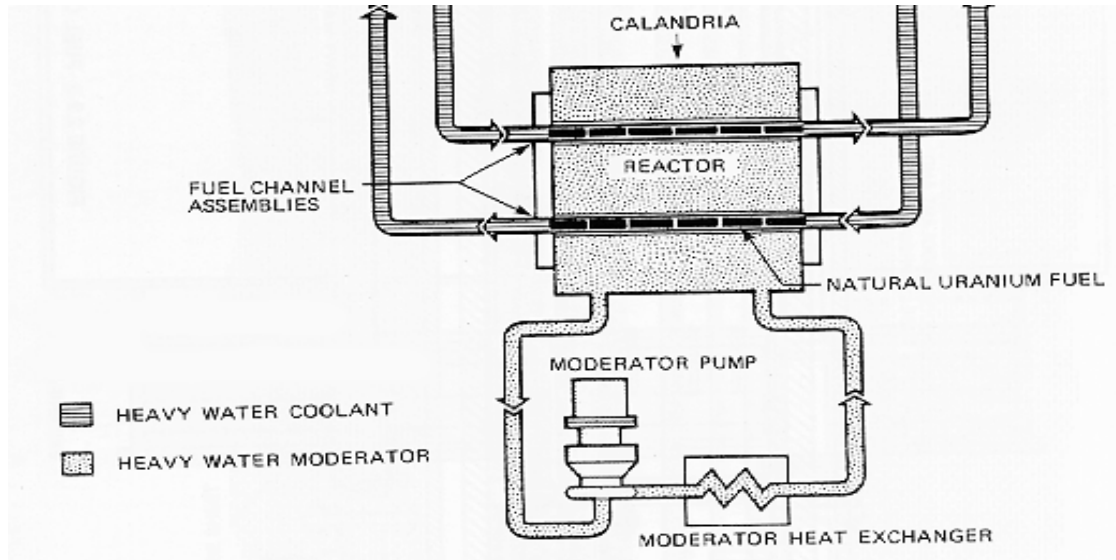

Figure 2.1. CANDU Reactor and Moderator.

2.1 REACTOR STRUCTURE ASSEMBLY

In order to maintain the top down approach, and since the design of the CANDU reactor was influenced to a significant degree by the inability of Canadian industry in the 1950s to manufacture a sufficiently large pressure vessel, the description of the reactor system begins with the assembly structure consisting of the calandria, end shields, pressure tubes and other major components that define so much of the CANDU characteristics. These components are illustrated in Figure 2.2.

The functional requirements of the reactor are as follows:

- to support and locate the fuel channels and contain the moderator such that a controlled nuclear fission chain reaction will occur to produce heat,
- to provide for the removal of the heat generated by nuclear fission,
- to provide for the fuel to be replaced while the reactor is operating,
- to accommodate the specified temperatures, pressures, radiation fields and loads acting on the reactor during normal and abnormal operation, fabrication, transportation, storage, installation, and all design basis events including a design basis earthquake.
- to locate and support the specified reactivity measurement, control and shutdown devices,
- to provide radiation and thermal shielding to protect nearby equipment and permit access for maintenance,
- to provide for major components, except the calandria-shield tank assembly, to be easily replaced or refurbished, which may be required after more than 30 years, to obtain a plant design life of 60 years.

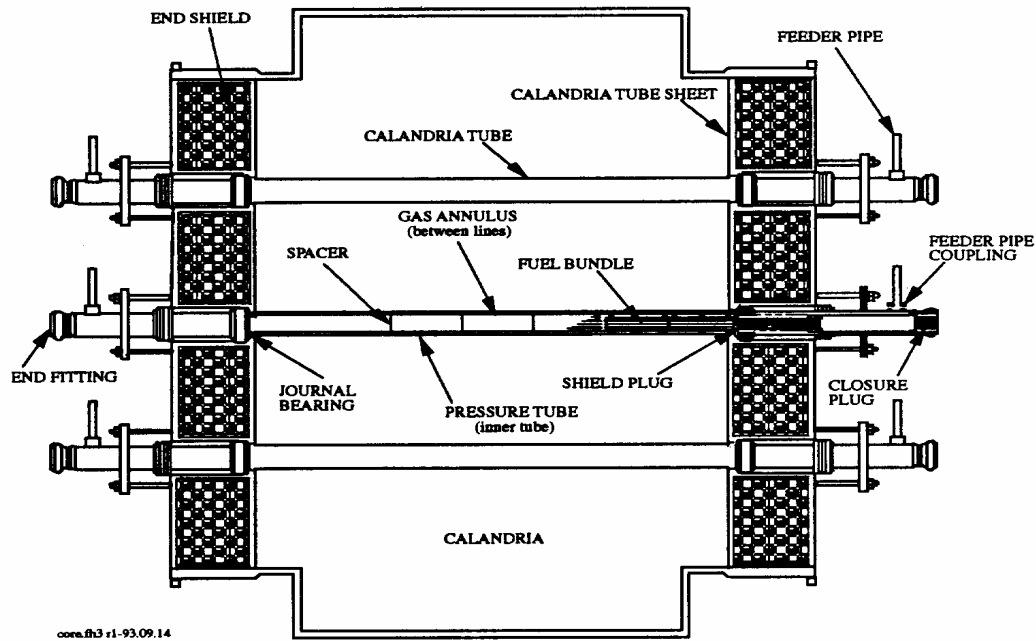

Figure 2.2. Reactor Assembly Structure.

The calandria shell, the two end shields and the shield tank and its end walls form the multi-compartment calandria-shield tank assembly. This assembly, plus the reactivity mechanisms deck, and the reactivity control unit thimbles and access tubes, comprise the reactor structure. This structure supports and contains the fuel channel assemblies and the reactivity control units, as well as the heavy water moderator, demineralized light water shielding and carbon steel balls shielding, as shown in Figures 2.3, 2.4 and 2.5.

The calandria-shield tank assembly consists of the horizontal cylindrical calandria shell, the end shields, the concentric cylindrical shield tank shell and its end walls. The calandria is a horizontal, cylindrical vessel of stainless steel, filled with low pressure heavy water moderator. It is spanned axially by the annealed Zircaloy-2 calandria tubes which join the two end shields together and form ducts through the calandria for the fuel channel pressure tubes. The calandria is spanned vertically and transversely by the Zircaloy guide tubes which house the reactivity control units. The calandria vessel is connected to the moderator system via inlet and outlet nozzles. Heat is generated in the moderator, mainly by the moderation of neutrons and gamma ray absorption. Heat is also transferred to the moderator from the calandria tubes and other in-reactor components. Moderator circulation within the calandria promotes uniform temperature through good mixing.

Each end shield is comprised of two tubesheets joined by the lattice tubes and a peripheral shell. The volume enclosed is filled with carbon steel balls and demineralized light water, for shielding and cooling. The shield tank end walls are the extensions of the end shield tubesheets which are secured to the vault walls, and through this arrangement the shield tank supports and encloses the calandria vessel. The shield tank, end shields and end walls provide shielding to permit maintainer access inside the reactor vault and the fuelling machine vaults during shutdown. Their shielding also protects the vault wall concrete from excessive heating at full power. Water is circulated through the end shields to remove the heat transferred from the primary heat transport system and generated by direct neutron bombardment.

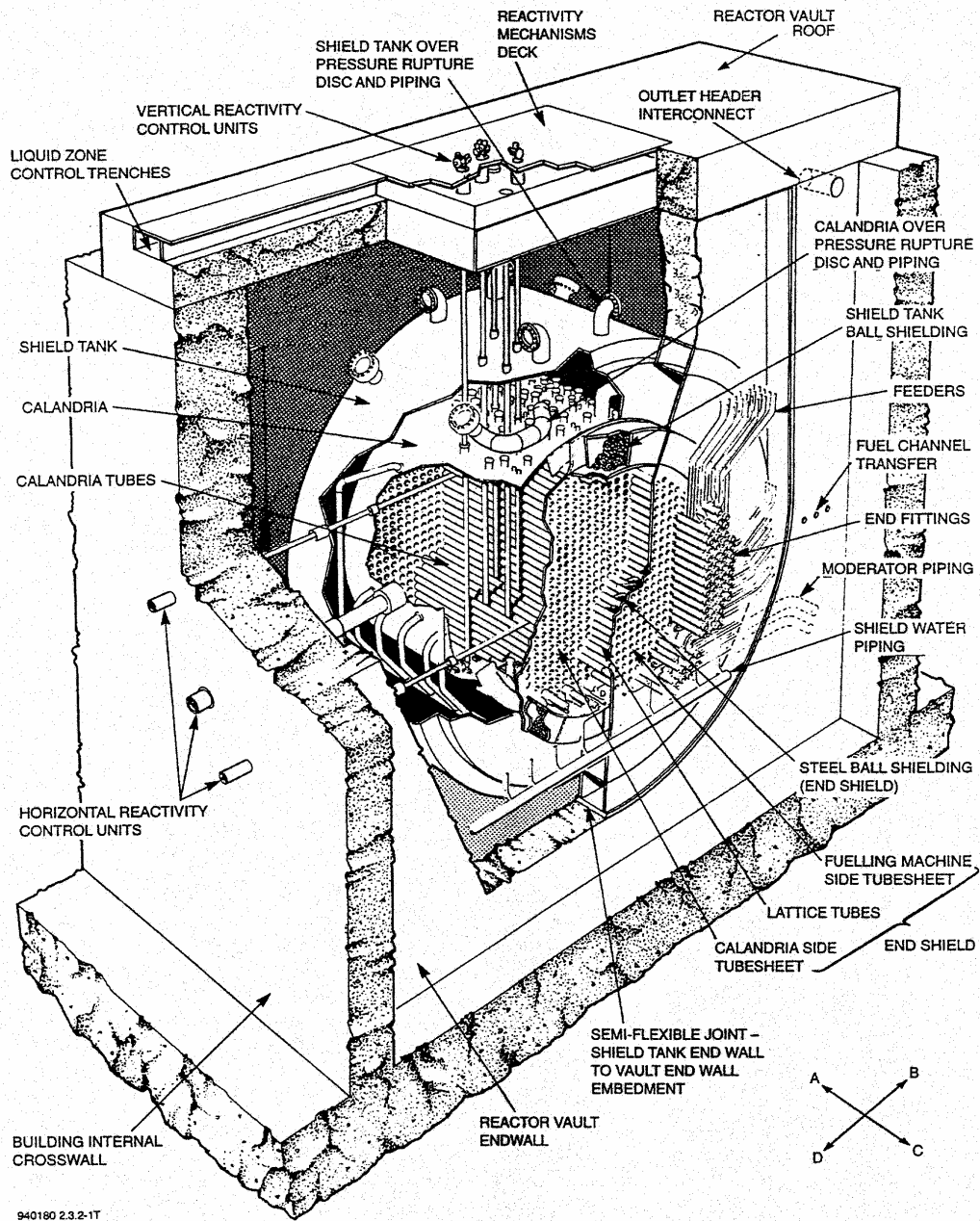

Figure 2.3. Reactor Assembly.

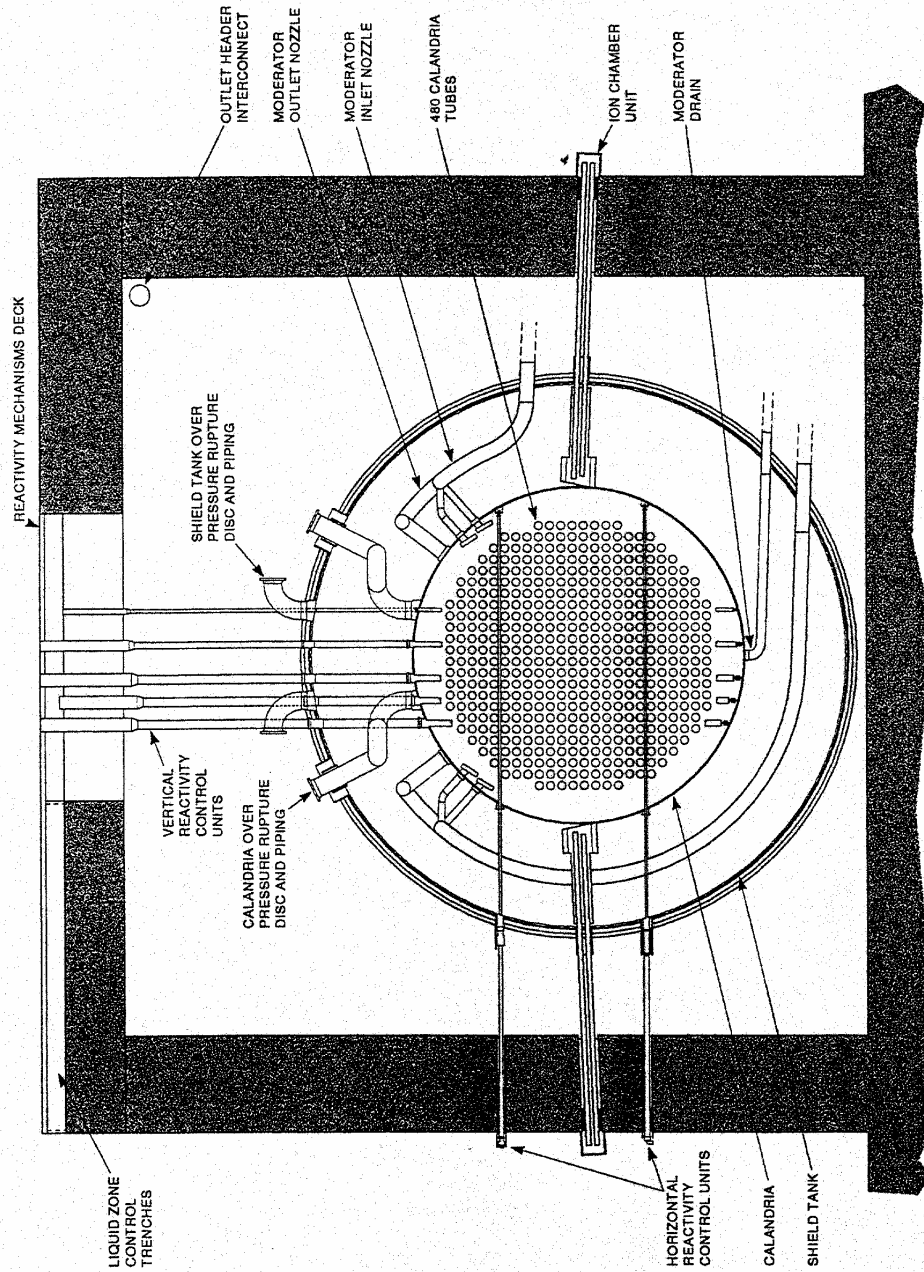
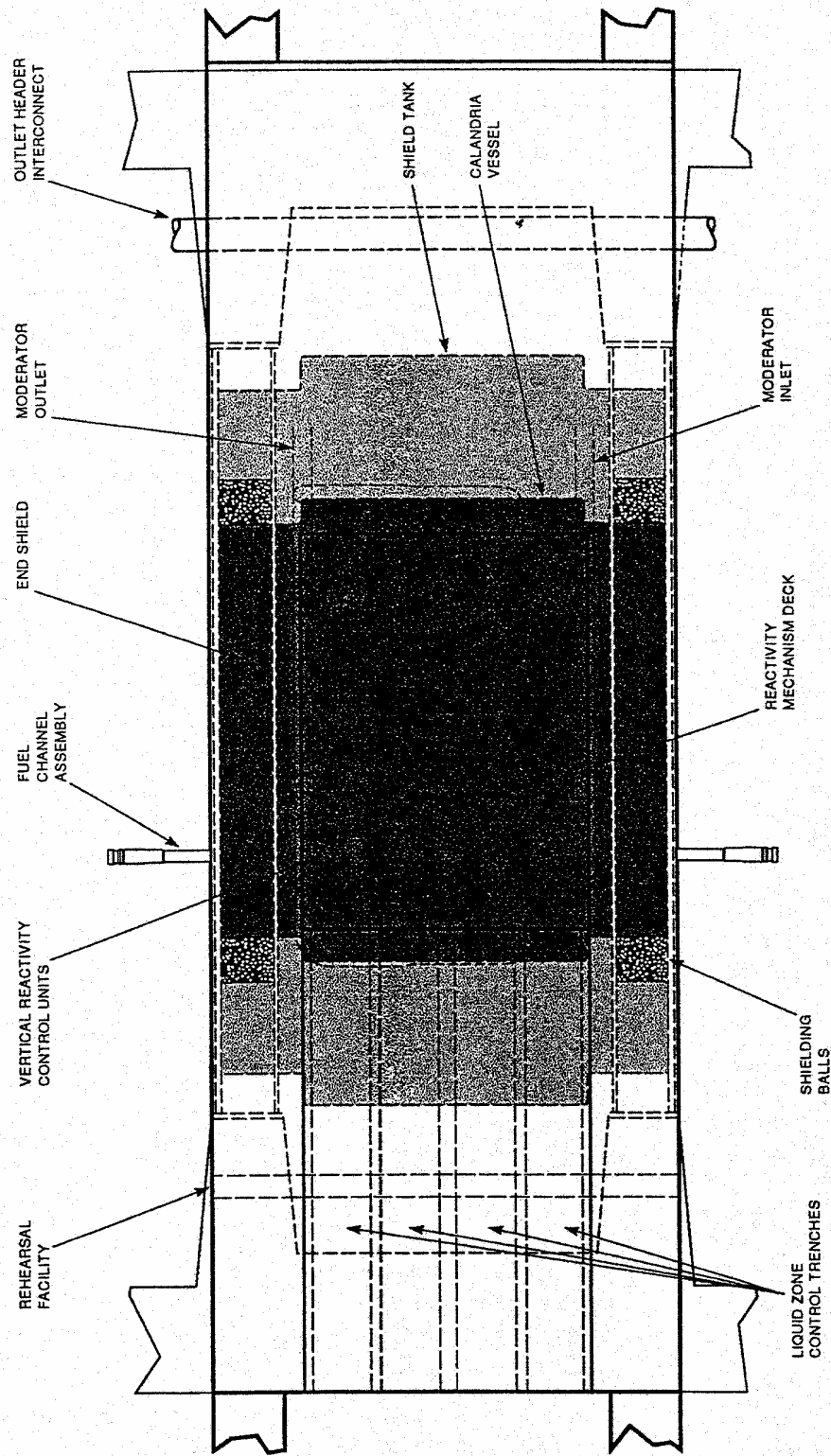

Figure 2.4. Reactor Structures Assembly-Front View.



940180-2.3.2-3

Figure 2.5. Reactor Structures Assembly - Plan View.

Fuel Channel Assemblies

The main functions of the fuel channel assemblies are to provide a low neutron-absorbing pressure tube, or boundary, to support and locate the fuel within the reactor core, and to allow for a controlled flow of the high pressure heat transport coolant around and through the fuel. Leaktight connections are provided to the heat transport inlet and outlet feeder pipes as well as to the channel closures at both ends. The fuel channel end fitting assemblies include a liner tube and shield plug at each end. A second tubular member, the calandria tube, forms a concentric container around the pressure tube. It is connected to the calandria end shield tubesheets using roll expanded sandwich type rolled joints. The annulus between the pressure tube and calandria tube is gas-filled, and provides thermal insulation to minimize heat loss from the high temperature heat transport system coolant to the cool moderator. The arrangement of fuel elements, pressure tube, annular space, calandria tube and moderator are illustrated in Figure 2.6.

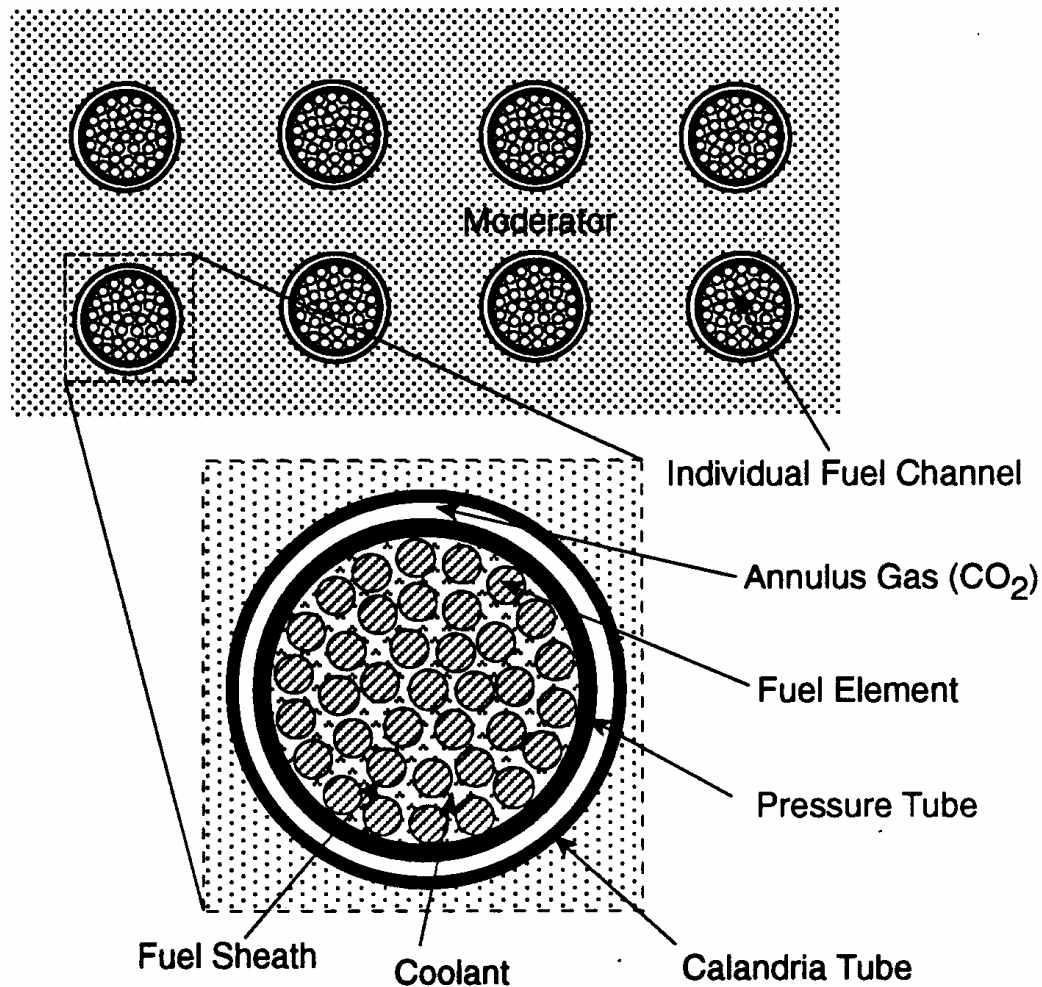

Figure 2.6. Arrangement of fuel elements, pressure and calandria tubes.

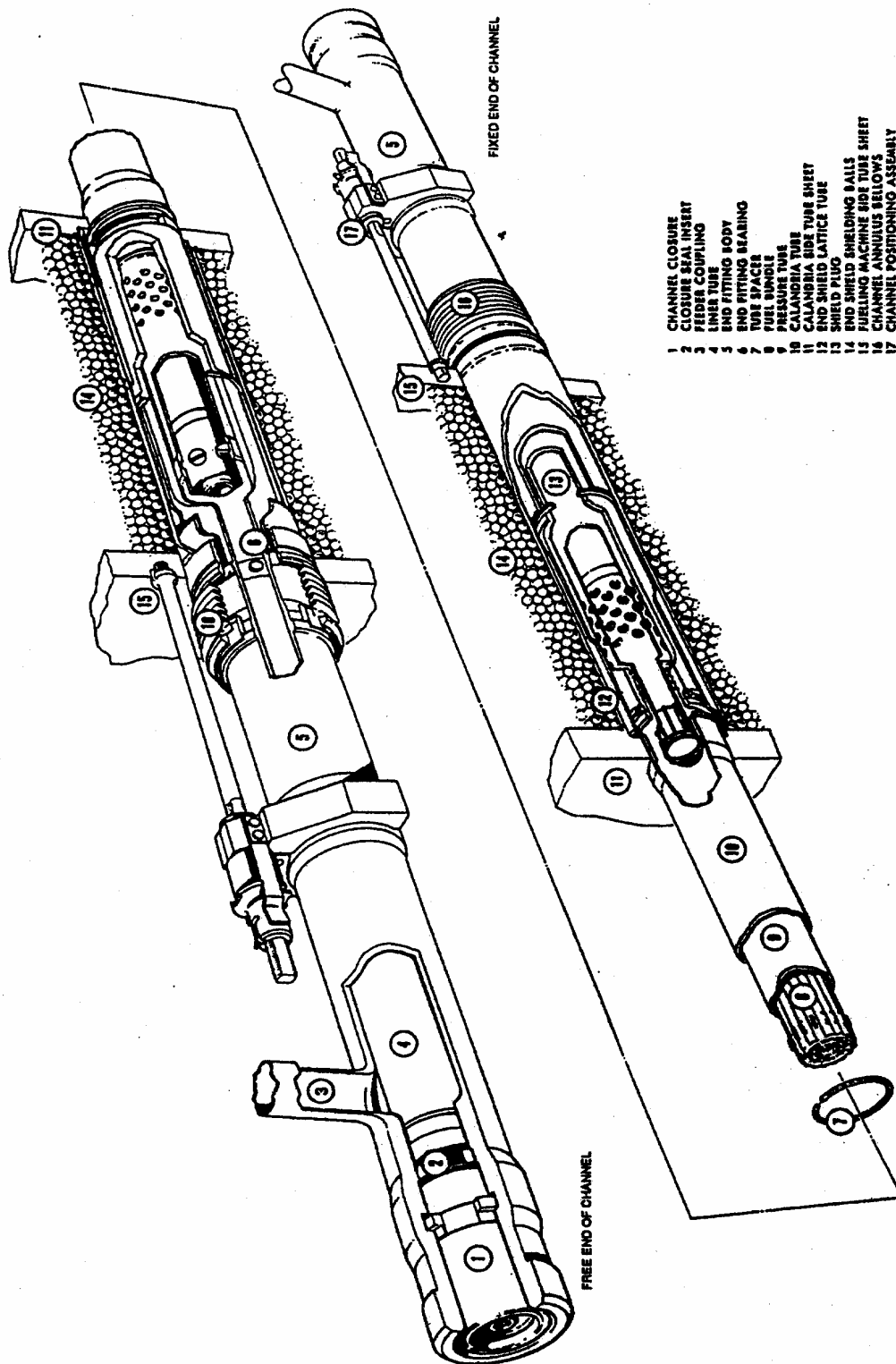

Figure 2.7. Fuel Channel Assembly.

For a complete reactor the fuel channel assemblies are arranged in a square pitch pattern to form a roughly circular core. Each of the assemblies comprises a pressure tube attached to inlet and outlet end fittings using roll expanded joints. The end fittings at either end can be made axially fixed and those at the other end free by adjustment of mechanical positioning assemblies connected to the fuelling side tubesheets. The annular gap between the end fittings and the lattice tube is sealed via a flexible bellows. The end fittings at each end are connected to feeder pipes by bolted or welded connections. The general arrangement of the channel is shown in Figure 2.7.

Calandria Tubes

The calandria tubes are an integral part of the reactor structure. They also provide essential fuel channel assembly functions. The calandria tubes are roll-expanded into the calandria side tubesheet. The calandria tubes are made of annealed Zircaloy-2, an alloy specifically developed for in-core components. This material has good resistance to corrosion and radiation and offers good neutron economy. The inner surface of the calandria tubes is surface conditioned to promote radiant heat transfer and optimize contact conductance during a potential loss-of-coolant accident.

Pressure Tubes

The pressure tubes, containing fuel bundles and heavy water coolant, are concentrically located inside the calandria tubes. Spacers in the annular gap between the pressure tube and the calandria tube separate the pressure tube from the calandria tube.

The zirconium-2.5wt% niobium alloy used for the pressure tubes combines low neutron absorption cross-section with high strength and good corrosion resistance, and low hydrogen absorption. A corrosion and wear allowance is included in the wall thickness of the pressure tubes. Extensive testing on this material has been done, and continues, to ensure the pressure tubes perform as required. This work has resulted in many advances in pressure tube technology including improved manufacturing procedures that provide lower initial hydrogen content and higher fracture toughness properties than previously obtained.

Fuel Channel Spacers (Garter Springs)

Four spacers per fuel channel assembly prevent direct contact between the pressure tube and calandria tube during normal operation. When installed, the spacers conform to the outside diameter of the pressure tube and are a snug fit around it, leaving a small diametral space between the spacer and the calandria tube to accommodate diametral creep and thermal expansion of the pressure tube. The design of the spacer does not impede the flow of the annulus gas. The spacers are a close-coiled helical spring, formed into a torus about a girdle wire.

2.2 FUEL

The functional requirements for a CANDU fuel bundle are as follows:

- The fuel bundle shall maintain its structural integrity, leaktightness and dimensional stability during transportation, during reactor operation under normal operating conditions including power maneuvering, and during refueling, storage and transportation following irradiation.
- The bundle shall have a specified hydraulic resistance to coolant flow, have a uniform coolant flow distribution within the bundle, have no local areas of flow stagnation adjacent to any element, and have sufficient margin-to-dryout under normal operating conditions.
- The bundle shall deliver its rated fission power at the specified operating conditions.
- The fuel element design shall be such as to maintain internal gas pressure below that of the coolant under normal operating conditions.

The CANDU 9 reactor uses the 37-element fuel bundle design of the CANDU 6. The fuel bundle uses two main materials: Zircaloy and uranium dioxide with 0.71% U235. When loaded with uranium dioxide pellets the bundle weighs about 24 kg, of which more than 90% is uranium oxide fuel. The bundle is shown in Figure 2.8.

The individual fuel elements contain three basic component parts: the uranium dioxide pellets, the sheath (with the CANLUB coating on the inside surface) and the end caps. In addition each element has bearing pads and/or spacer pads brazed to the outer surface. End plates are welded to the end caps to hold the elements in a bundle assembly and bearing pads brazed near the ends and at the mid-point of each outer element to provide spacing between the bundle and the pressure tube.

The Fuel Sheath are designed to:

- contain the uranium dioxide under normal operating conditions,
- minimize neutron absorption,
- minimize corrosion and hydrogen/deuterium pickup,
- minimize strain effects,
- minimize resistance to heat transfer,
- minimize hydraulic head loss,
- withstand normal operating (including refueling) loads.

Zircaloy-4 is chosen as the fuel sheath material because of its excellent nuclear characteristics of low neutron absorption, good corrosion resistance and low hydrogen pickup. Material properties and heat treatments are specified to optimize sheath ductility at high irradiation levels.

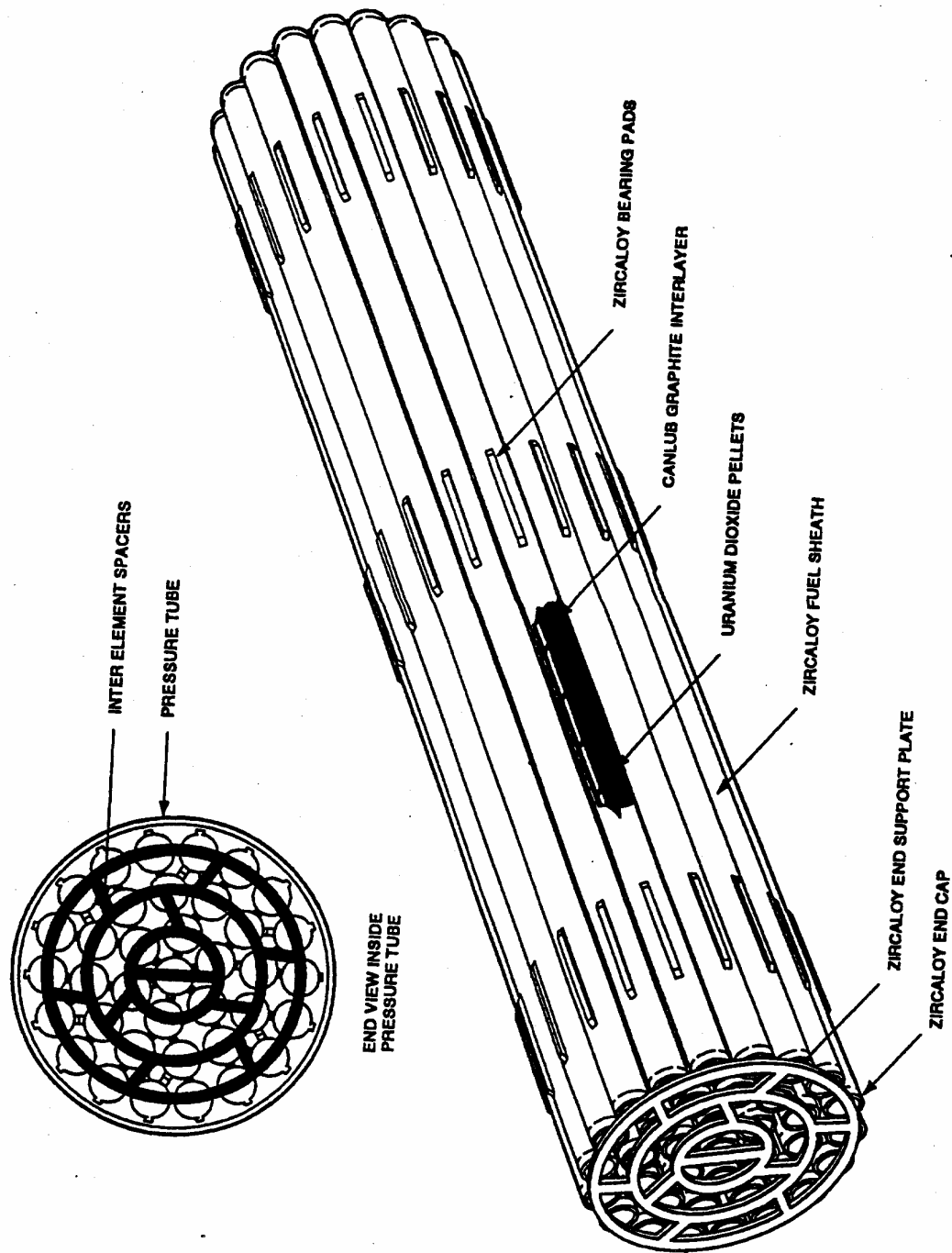

Figure 2.8. 37-Element Fuel Bundle.

The sheath dimensions are specified, as in all CANDU fuel designs, to allow the sheath to collapse into diametral contact with the uranium dioxide pellets at operating conditions. At the same time, production dimensions are controlled to prevent longitudinal ridges, to prevent axial collapse and to allow easy pellet loading.

The uranium dioxide pellets are designed to:

- maximize the amount of fissile material in each fuel element,
- minimize volumetric changes during irradiation,
- control fission gas releases,
- minimize circumferential ridging of the sheath, and
- be economical to produce.

The material properties of the uranium dioxide (0.71% U235) are maintained within precise limits, for example, density and oxygen-to-uranium ratio, which strongly affect the thermal behaviour and, hence, fission gas release of the uranium dioxide. Other features of the uranium dioxide pellets, such as pellet dishing and length/diameter ratio, optimize fuel performance.

A thin layer of graphite is applied on the inner surface of the sheath to reduce the effects of pellet-cladding interaction. Since the introduction of CANLUB to the production of CANDU fuel in 1973 there have been very few power ramp defects in the commercial power reactor fuel.

The fuel elements are filled with unpressurized helium to allow all elements to be helium leakage tested during fabrication. The helium also enhances the pellet/sheath contact conductance at start of life.

2.3 MODERATOR SYSTEMS

This group of systems includes the main moderator system and a number of auxiliary systems.

The main moderator system consists of two interconnected circuits, each containing a pump and two heat exchangers, that circulate the heavy water moderator through the calandria, and remove the heat generated within the moderator during reactor operation. The moderator system also acts as a medium for dispersion of reactivity control agents, and the liquid neutron absorber of shutdown system number 2. The concentration of reactivity control agents is controlled by the moderator liquid poison system and the moderator purification system. Other integrated moderator auxiliary systems include the cover gas system for pressure and deuterium control, the moderator heavy water collection system, and the moderator sampling system.

Should moderator loss or leakage occur at a rate beyond the capability of the heavy water makeup system, the reserve water tank can be valved in to supply light water by gravity to the moderator thereby maintaining the moderator heat sink capability.

The moderator in the calandria provides a medium to slow down high energy fission neutrons in the reactor to the appropriate thermal energy level to promote further nuclear fission. To provide the necessary operating conditions the moderator system performs the following functions:

- Removes the heat that is continuously generated in the moderator and maintains a controlled bulk temperature in the calandria.
- Maintains the chemical purity within specified limits by providing a means for diverting a stream through a purification loop.
- Allows short term and long term reactivity control by providing a means for injection and removal of neutron absorbing chemicals.
- The supply, drainage and sampling of the heavy water.
- Maintains a controlled bulk temperature in the calandria by providing sufficient heavy water cooling flow through the heat exchangers and ensures adequate net pump suction head for the pumps under all normal and upset reactor operating conditions.
- Maintains the moderator level in the calandria within the design operating level during normal operation.
- Maintains moderator level within design limits to minimize cover gas compression and hydrostatic pressures on the lower calandria tubes during upset conditions.
- Provides adequate circulation during maintenance and normal shutdown with one moderator system circuit operating.
- Serves as a heat sink with adequate circulation for heat removal following a loss-of-coolant accident coincident with loss of emergency core cooling, with or without Class IV power.

The moderator takes away almost 5% of the heat energy produced in the reactor. If moderator heat removal stops, the moderator in a reactor at full power will boil in just a few minutes. At full reactor power, there are several sources of moderator heat.

- 70% to 80% of the heat in the moderator is produced by neutron thermalization and absorption of gamma ray energy and indirectly by heating of the moderator structure. The neutrons typically contribute more than half of this. This heat source disappears when the fission process stops.
 - Gamma rays from fission product decay and from decay of activation products in reactor components indirectly produces 15% to 25% of the heat in the moderator. Decay gamma rays from fission products generate most of this decay heat. This heat decreases slowly after a reactor shutdown.
 - Conventional heating (conduction, convection, thermal radiation and friction) accounts for about 3% to 5% of moderator heating. The annulus gas does not insulate the hot pressure tube perfectly. Conduction, convection and heat radiation transfers some heat across the annulus. The moderator pumps, when running, also produce heat by fluid friction.
-

The main moderator system is shown in Figure 2.9. It is comprised of two parallel interconnected circuits, each consisting of one 50 percent pump, two 25 percent heat exchangers, and associated isolation valves, piping and instrumentation. Moderator system connections are provided for the purification, liquid poison addition, heavy water collection, heavy water supply, sampling systems, and the reserve water system.

Circulation of the moderator in the calandria is attained by drawing heavy water from both sides of the upper portion of the calandria and returning it, after cooling, through the nozzles located on both sides of the calandria at an elevation lower than the outlet nozzles. The inlet nozzles inside the calandria are directed downward close to the calandria shell to promote a flow pattern that achieves a uniform temperature distribution.

The moderator pumps provide circulation of the moderator heavy water through the heat exchangers which remove the heat generated in and transferred to the moderator. During normal reactor operation both moderator cooling circuits provide circulation through the calandria. During reactor shutdown, only one cooling circuit is required for moderator circulation.

The calandria is initially filled with heavy water from the heavy water supply system. On initial startup and on startups following a long shutdown the heavy water is heated to the normal operating temperature by low reactor power and pump heat. Volumetric expansion of the heavy water from heating causes the moderator to rise into the moderator head tank, to the normal operating level.

The moderator level in the calandria during warm-up and cooldown is accommodated by the head tank. During normal operation, inventory is maintained by feed from D₂O supply when D₂O is being removed from the system for upgrading.

Relief valves, connected to the cover gas system provide overpressure protection to the moderator system and the calandria during normal plant operation.

Austenitic stainless steel is used for all moderator system components in contact with heavy water.

The moderator heat exchanger rooms and the moderator pump rooms are inaccessible during normal operation due to radioactivity in the circuits. Repair to one of the 50 percent capacity moderator circuits can be carried out after isolating the respective circuit with the reactor power at 60 percent or less of full power. Access to the individual equipment rooms is permitted after a six hour period to allow activity decay.

Drains are provided from all moderator equipment rooms for collection of moderator heavy water in case of a leak or a break in the moderator system, or a leak in the recirculated cooling water system. A pump is used for pumping leakage to the radioactive liquid waste management system.

The moderator inlet and outlet pipes from the calandria shell up to the first pipe support outside the reactor structure and the drain pipe from the bottom of the calandria up to and including the manual isolation valve are qualified for a design basis earthquake, Category A.

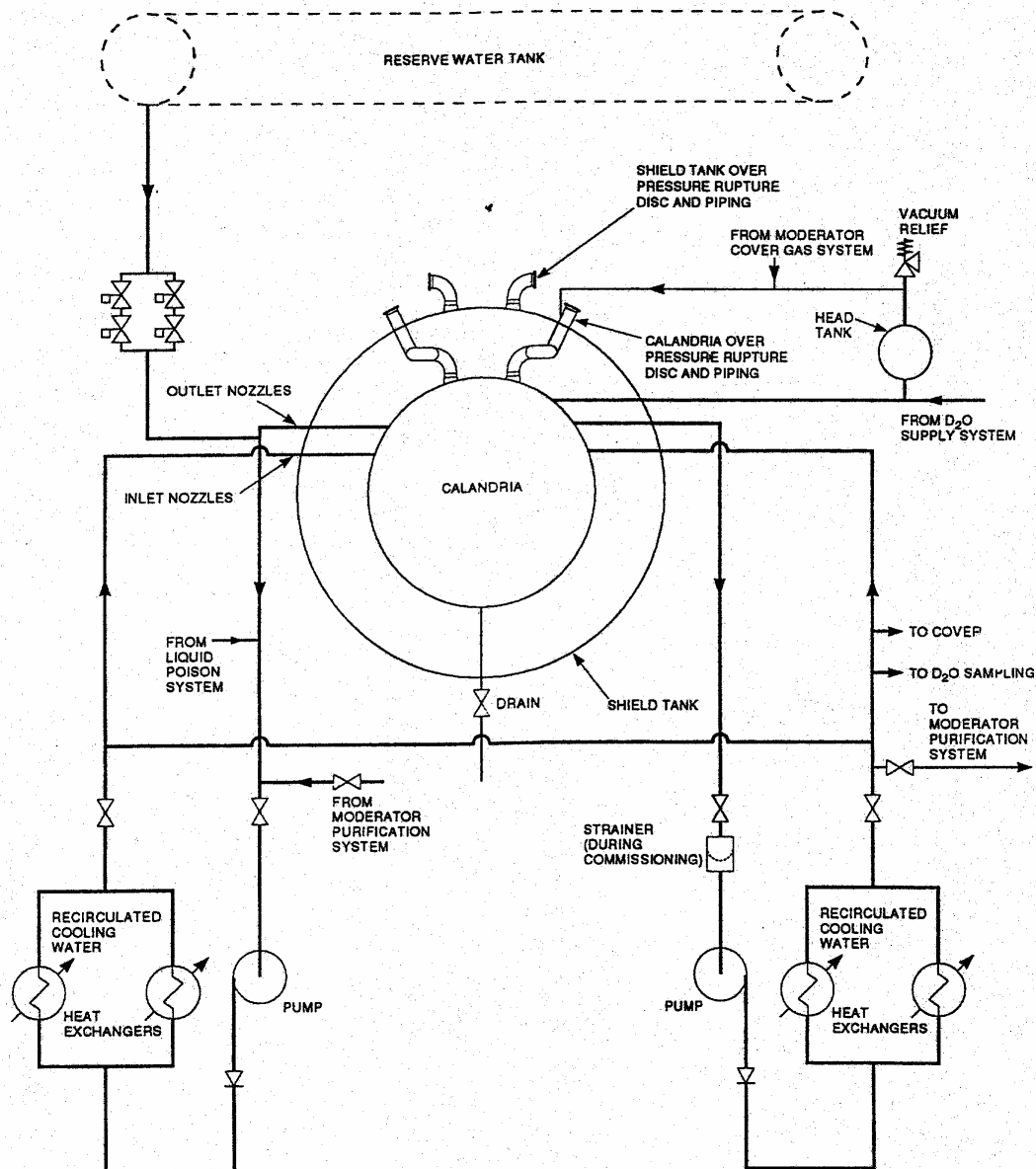

Figure 2.9. Moderator System Flow Diagram.

The seismic qualification as described precludes the calandria from draining following an earthquake of design basis intensity since the moderator inlet and outlet nozzles are connected to the calandria at a high elevation.

In the case of a site design earthquake 24 hours following a loss-of-coolant, the heat transport system is at a low temperature due to cooling by the emergency core cooling system. Therefore the heat load to the moderator system is reduced to insignificant levels in the long term.

In the event of an accident that requires the moderator as a heat sink, coincident with moderator system leakage at a rate in excess of the supply capability of the D₂O makeup system, the moderator makeup is provided by the reserve water system. In this scenario, demineralized water from the reserve water tank can be gravity fed to the moderator system. For long term operation under this condition, the reserve water system recovery pump returns the water collected from the vault floor to the moderator system.

The moderator system is environmentally qualified to withstand the moisture, temperature, pressure, radiation and water level associated with either an in-core or an out-of-core loss-of-coolant.

Control of the moderator temperature at the calandria outlet is accomplished through the use of a feedback control temperature loop and a feed forward term that is a function of reactor power. The temperature of the moderator, measured at the suction of the pumps, is utilized to modulate the control valves on the recirculated cooling water flow line to the moderator heat exchangers.

The feedback signal is the median signal from the temperature sensors. Control of the calandria moderator outlet temperature is achieved by the use of two control valves, one large and one small, for each pair of heat exchangers. At high reactor power the larger diameter valve is manipulated with the smaller valve fully open. At low power the larger valve is closed and the smaller valve is used for control.

The temperature of the moderator at the exit of the moderator heat exchanger is monitored by temperature sensors located at the outlet of the heat exchangers. Control room indication is provided. High and low temperature alarms are annunciated in the control room when the temperature settings, which are a function of reactor power, are exceeded.

The level of the moderator in the head tank is measured by narrow range differential pressure transmitters, and annunciation is provided in the control room for high and low level. In addition, the moderator level is measured between the top of the calandria and the bottom of the calandria to indicate level changes during filling or draining of the calandria.

Moderator Cover Gas System

The moderator cover gas system performs the following functions:

- Provides an inert (helium) gas cover for the moderator to prevent corrosion and reduce radioactivity.
- Prevents explosive concentrations of deuterium gas from accumulating in the system.
- Limits variations in pressure to keep stress levels at values acceptable for the calandria assembly and the fuel channel calandria tubes.
- Provides pressure balance between the liquid injection shutdown system and the cover gas system, and between the reactivity control unit thimbles and the cover gas system.
- Purges air from the calandria and the reactivity control unit thimbles after maintenance.
- Purges the cover gas if the deuterium concentration increases above a limit determined by flammability considerations.
- Blankets the inside of the calandria when the moderator is drained.
- Provides connections to the gas chromatograph for continuous monitoring of the amount of deuterium in the cover gas.

The moderator cover gas system is a closed recirculating circuit comprising two compressors, two recombination units (each equipped with flame arrestors and heaters), a cooler, helium and oxygen bottle stations and associated valves, piping and instrumentation.

Under normal operating conditions one compressor operates, with the other on standby. The compressor draws cover gas from the gas space over the moderator free surface in the thimble guide tubes and two of the four calandria relief ducts and discharges to the two recombination units, in a parallel configuration. Although each of the recombination units is rated at 100 percent capacity, both units function simultaneously during normal operation. Each of the recombination units is equipped with an upstream and downstream flame arrestor and upstream heaters. Flame arrestors prevent flame propagation in either direction from the recombination units. The cover gas stream from the recombination units is cooled in a direct-contact cooler using moderator as the cooling medium.

The moderator cover gas system equipment is located in an accessible area of the reactor building. Operation of the cover gas system is not necessary for public safety during or after an earthquake; therefore seismic qualification is not required.

Moderator Liquid Poison System

The moderator liquid poison system performs the following functions:

- Adds negative reactivity to compensate for excess reactivity in new fuel.
- Adds negative reactivity to compensate for the reduction of the fission product xenon-135 during a startup following a prolonged shutdown.
- Provides a means for adding negative reactivity, to compensate for reactivity increase caused by non-normal refueling or adjuster operation.
- Adds negative reactivity to compensate for the temporary reduction in xenon-135 during startups and upward power maneuverings.
- Adds sufficient negative reactivity to guarantee that the reactor cannot become critical during a major shutdown.

Boron, as boric anhydride, used for long term control, may be used to compensate for excess reactivity in a core loaded with fresh fuel. Gadolinium, as gadolinium nitrate, satisfies the short-term reactivity control requirements, including a xenon transient during a reactor power increase or following a reactor 'poison-out'.

Moderator Purification System

The moderator purification system performs the following functions:

- Maintains the purity of the moderator heavy water to minimize radiolysis, thus preventing excessive production of deuterium and minimizing corrosion of components and crud activation.
- Adjusts the concentration of the soluble neutron poisons (boric anhydride and/or gadolinium nitrate) in response to reactivity demands.
- Removes the soluble poison, (gadolinium nitrate), after operation of the liquid injection shutdown system.

The purification system motorized ion exchanger inlet valves are automatically closed during reactor shutdown and when either of the shutdown systems is not available to guard against inadvertent criticality while the reactor is in a guaranteed shutdown state. Purification flow is manually shut off if the high temperature limit is exceeded for an extended period, to preclude thermal degradation of the ion exchange resins.

Five ion exchange columns are provided in the moderator purification system to satisfy the three modes of operating conditions. The operating mode dictates the ion exchange column required to be valved in for purification. Two columns are designated for normal clean-up operation, two ion exchange columns are used for boron removal and one column is provided for gadolinium removal. Once the core has achieved the equilibrium fuel condition, following initial reactor operation, the resin type used in all columns is uniform to allow full interchangeability of columns during all modes of operation if needed. Any solid particles including fine corrosion products are removed in the ion exchange bed and with the spent resins.

Heavy Water Collection System

The moderator heavy water collection system performs the following functions:

- Collects heavy water leakage from various points in the moderator and auxiliary systems including:
 - moderator pump seals,
 - the interpacking space of the moderator system gate valves,
 - drains from the moderator sample station,
 - discharge from the overpressure protection devices in the purification system,
 - drains between pump isolation valves and from pumps during maintenance,
 - drains between heat exchanger isolation valves during maintenance.
- Transfers accumulated reactor grade heavy water to the main moderator system and the downgraded heavy water to the heavy water cleanup system.
- Provides recirculation, sampling and storage facilities for the accumulated heavy water.
- Provides means for monitoring D₂O leakage and drain flows and of determining the source.

The heavy water collection system includes a tank, a pump, and a sample station, and associated instrumentation and shielding. Heavy water from the moderator pump seal leakage and the moderator valves interpacking leakage flows by gravity through drain lines, each containing a sight glass. Leakage can be visually monitored at the sight glasses. All of these drain lines discharge into the collection tank after passing through a strainer. Drains between the heat exchanger isolation valves and the pump isolation valves are at a low elevation and are forced to the collection tank by instrument air. The heavy water collected is usually of reactor grade.

The heavy water collection pump transfers the collection tank contents to the main moderator circuit, provided that the collected heavy water is reactor grade. If the collected heavy water is of downgraded isotopic, the tank contents are transferred to the heavy water cleanup system. The quality of the collected water is determined by a sample station connection. A recirculation line from downstream of pump to the collection tank ensures the sample is representative.

Common lines connect the pump suction and discharge with those of the heat transport heavy water collection pump for redundancy. There is an isolation valve on each interconnect to segregate heat transport system and moderator system heavy water.

Copyright information for Chapter 2:

Figures on pages 2-3, 2-4, 2-5, 2-6, 2-8, 2-11 and 2-15 are from CANDU® 9 480/NU Technical Description, AECL document 69-01371-TED-001 Rev. 1, January 1995. Reprinted with permission of Atomic Energy of Canada Limited (AECL).

Figures on pages 2-2 and 2-7 are from unpublished training documents of Ontario Hydro. Reprinted with permission.

CHAPTER 3

REACTOR CONTROL

CHAPTER OBJECTIVES:

At the end of this chapter, you will be able to describe the following features of the reactor control systems:

1. The main functions and unique requirements of reactor control;
2. The instruments and techniques used to monitor reactor power;
3. The devices and systems used to control reactor power;
4. The control algorithms used to achieve the objectives of reactor control.

This chapter describes the systems, equipment and techniques used to achieve control of reactor power throughout its designed range of operation. The requirements for reactor control are first examined, followed by the instrumentation needed to monitor reactor power. The various methods available for reactivity control are described next, including the devices and support systems needed to assure the reliable operation of these control systems. The last section explains how the computer programs implement the control algorithms that take the various power measurements and compute the reactivity device changes needed to achieve the desired reactor response.

3.1 REACTOR CONTROL REQUIREMENTS

The main functions of the reactor control system are as follows:

- Automatic control of reactor power to a given setpoint at any power level between 10^{-7} full power and 1.0 full power. The setpoint may be specified by the operator (alternate mode) or by the steam generator pressure control program (normal mode).
- Maneuvering of reactor power at controlled rates between any two power levels in the automatic control range (above 10^{-7} full power).
- Insertion or removal of reactivity devices at controlled rates to maintain a reactivity balance in the core. These devices compensate for variations in reactivity arising from changes in xenon concentration, fuel burnup, moderator poison concentration or reactor power.
- Maintaining the neutron flux distribution close to its nominal design shape so that the reactor can operate at full power without violating bundle or channel power limits. This requirement, along with the natural spatial instability of the core, dictates the need for spatial control.
- Monitoring of a number of important plant parameters and reduction of reactor power when any of these parameters is out of limits.
- Withdrawal of shutdown rods from the reactor automatically when the trip channels have been reset following a reactor trip on shutdown system number 1.

The reactor control system is an integrated system comprising reactor flux and thermal power measurements, reactivity control devices, and a set of control system programs, all coordinated to perform three main functions:

- a. Monitor and control total reactor flux and power so as to satisfy the station load demands.
- b. Monitor and control reactor flux shape.
- c. Monitor important plant parameters and reduce reactor power at an appropriate rate if any parameter is out of limits.

There are several unique characteristics of nuclear power plants in general and CANDU generating units in particular which need to be appreciated before studying the equipment and techniques used to control such reactors. These special requirements are discussed in the following sections.

First Criticality

During and after initial fuel loading, the reactor is kept in a guaranteed shutdown condition by means of moderator poison. First criticality is achieved by gradual removal of this poison using the ion exchange columns of the moderator purification system.

The reactor regulating system monitors power level over the full operating range. Three systems of instrumentation are used, each covering a different range:

- a. The startup instrumentation is used from the spontaneous fission power level (approximately 10^{-14} of full power) up to approximately 10^{-6} of full power.
- b. The ion chamber system from 10^{-7} to 1.5 full power.
- c. The in-core flux detector system above 10^{-1} full power.

The power range monitored by the startup instrumentation corresponds to an in-core thermal neutron flux range up to approximately 2×10^8 n/cm² s. To accomplish this, BF₃ counters in conjunction with standard neutron counting equipment are used. To monitor a power range of eight decades without saturating the counting capability of the instrumentation, both in-core and out-of-core detectors are used. The startup counters provide alarm trips and indicators to trip three channels for shutdown system number 1 for: high power, high rate, and failure of detector voltage.

A small neutron source (e.g., 370 MBq Am-Be) giving approximately 2.5×10^4 neutrons per second is used solely for testing the entire startup instrumentation system prior to installing the BF₃ counters in-core and in the ion chamber housing. Subcritical multiplication of spontaneous fission neutrons provides a sufficiently large count rate to be accurately measured.

Load Following

In the load-following case, if power reductions are large enough and of sufficient duration to require a significant number of the adjuster rods to be withdrawn to compensate for the associated transient in Xenon-135, restraints on the rate of recovery to full power may occur. As discussed in Section 3.1.2.6, the adjuster system can compensate for Xenon buildup after a power reduction to any level above about 60 percent of nominal power.

Assuming an initial power of 100 percent with equilibrium fuel in the reactor, the Xenon load at a steady level, and normal flux shape (all adjuster rods fully inserted, all mechanical absorbers fully withdrawn), the reactor power may be reduced to about 60 percent of full power at rates of up to 10 percent of full power per minute. The power may be held at the new lower level, indefinitely. Time to return to high power depends on the degree and duration of the power reduction. In most cases, a maximum of four hours is required to return to 98 percent of full power from 60 percent of full power.

Trip Recovery

When the reactor trips or the power is reduced in a controlled manner because of load-following or other requirements, a temporary increase in the Xenon-135 concentration occurs. The magnitude of the increase depends on the time period that the reactor is shut down or is operated at a reduced power level. It also depends on the magnitude by which the power level has been reduced and the rate at which it is reduced in the case of a controlled change in power level.

In the event of a reactor trip from full power, power must be raised again within about 35 minutes or the xenon concentration will rise beyond the capacity of the regulating system to compensate. At this point, all of the adjuster rods must be withdrawn to compensate for the xenon buildup. This results in peaking of the power distribution relative to the normal steady-state full-power condition. Consequently, power cannot be increased immediately to 100 percent. However, the power can be raised sufficiently to 'burn out' the excess Xenon-135, and as this happens, the adjuster rods can be reinserted, which in turn permits increasing power.

Spatial Instability and Sources of Perturbation

During operation, the reactor can be subjected to perturbations such as those caused by refueling, power cycling, reactivity device movements and reactor trip with subsequent startup. The response of the reactor to these perturbations will depend upon its inherent stability - a characteristic determined largely by the lattice properties, the reactor size, the unperturbed flux distribution and the magnitude and sense of any feedback (due to change in fuel temperature, coolant density, Xe-135 concentration and control rod position).

Spatial flux instability results from neutronic decoupling of reactor regions. For an unstable reactor, a small flux perturbation can lead to power oscillations between opposite regions of the core; diverging with time, due to separation by a neutron-removing medium. In general, the larger the reactor core, the greater is its tendency to spatial instability.

The most common flux perturbations arise from on-power refueling operations and from movements of reactivity devices. Apart from exciting the flux harmonics, on-power refueling leads to local channel power variations about the nominal value. These are local effects and are allowed for in the design margins.

Automatic Spatial Control

The spatial control system in CANDU 9 prevents any global flux tilts which asymmetric fuelling would tend to induce and maintains a stable power distribution for all of the normal movements of reactivity devices (adjuster rods or mechanical control absorbers).

The zone controller compartments are used both for bulk and for spatial flux control. Bulk reactivity and flux level are controlled by varying the average zone controller fill. Spatial control is achieved by individually varying the zone controller fills.

A prompt measurement of zone flux is made with self-powered in-core detectors. A slightly delayed zonal power signal is obtained from calibration of an on-line flux mapping system. Such signals are used to drive each of the zone control compartments.

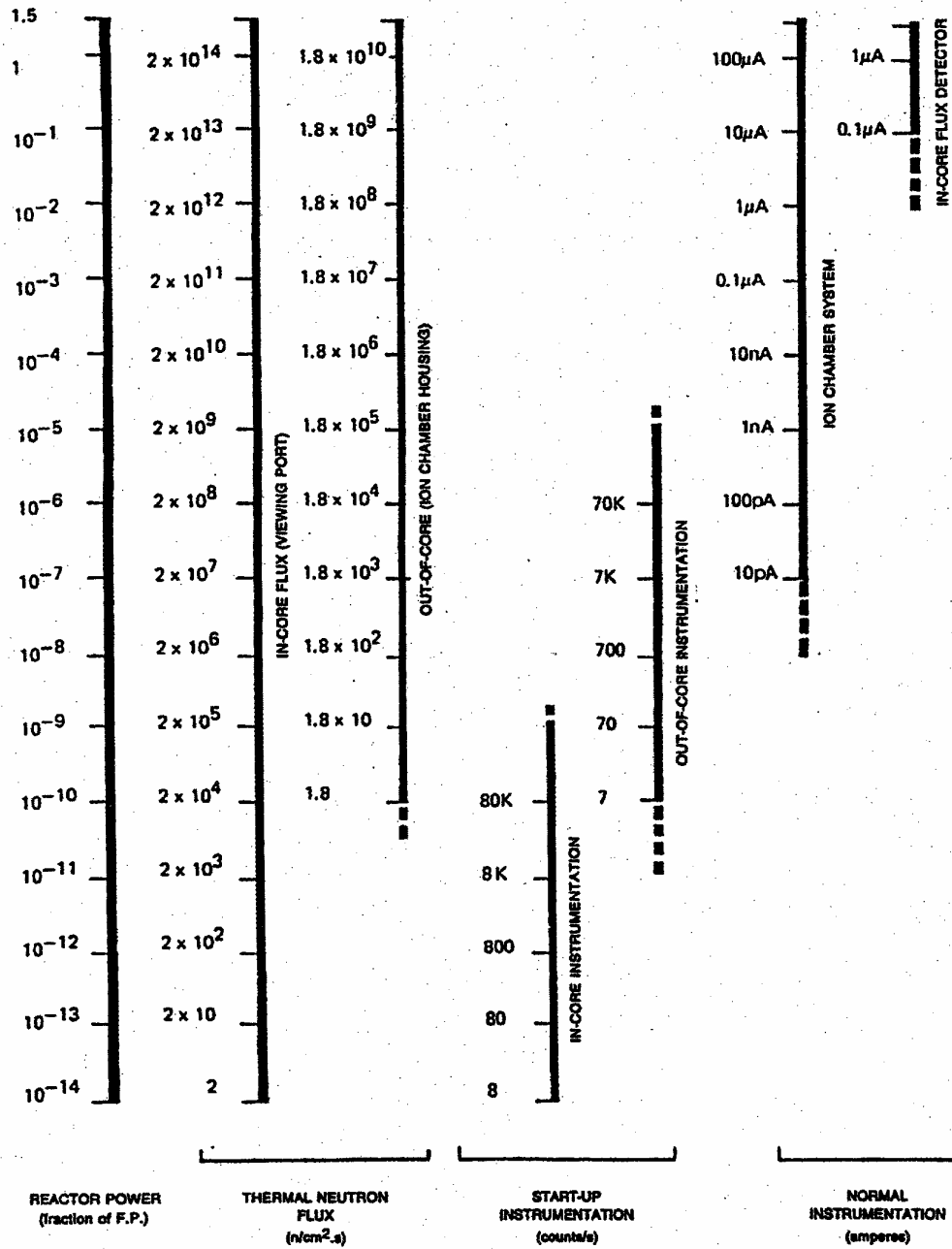

Figure 3.1. Range of Sensitivity of Nuclear Instrumentation for Reactor Power Measurement.

3.2 REACTOR INSTRUMENTATION

Three instrumentation systems are provided to measure reactor thermal neutron flux over the full power range of the reactor. Startup instrumentation covers the eight-decade range from 10^{-14} to 10^{-6} of full power; the ion chamber system extends from 10^{-7} to 1.5 of full power, and the in-core flux detector system provides accurate spatial measurement in the uppermost decade of power (10 percent to 120 percent of full power). This is shown graphically in Figure 3.1.

The fuel channel temperature monitoring system is provided for channel flow verification and for power mapping validation.

Startup Instrumentation

This system is used on initial plant startup or after a prolonged shutdown, and performs a dual regulating and protective role over the lowest power range when the normal flux measuring instrumentation of the regulating and shutdown systems is off scale. This occurs on the initial reactor startup and during a shutdown of 40 to 70 days or more when the photo-neutron source decays below the sensitivity of the ion chamber system.

Two sets of neutron detectors (BF_3 counters) are used covering the range from 10^{-14} of full power up to 10^{-6} of full power. One set, located in-core, covers the range from spontaneous source level (10^{-14} full power) to 10^{-9} full power. The in-core detectors are installed via the vertical viewing port penetration from the reactivity deck. This instrumentation is removed after the low power commissioning period.

The other set of neutron detectors is located out of core in the three spare cavities of the shutdown system number 2 ion chamber housings.

The detector outputs are connected to startup monitoring instrumentation located temporarily in the main control room. The signals are processed to give log and linear count rate indications and rate of change information. This information is used for protection and monitoring during the approach to criticality.

In this range, the reactor is controlled manually by the operator from the control room. The operator monitors and records the output of the neutron counting instrumentation which is mounted in a mobile cabinet. This instrumentation is divided into three redundant channels and includes trip comparators which are connected into the D, E and F channels of the trip logic of the shutdown system number 1. Shutdown rods will drop into the core under any one of the following three conditions:

- a. the count rate exceeds the setpoint,
- b. the rate of change is excessive,
- c. two or more channels of the instrumentation fail.

On restart after an extended shutdown, the system is normally on-scale with the out of core detectors; in-core counters are used only on the initial startup. The arrangement of the system is shown in Figure 3.2.

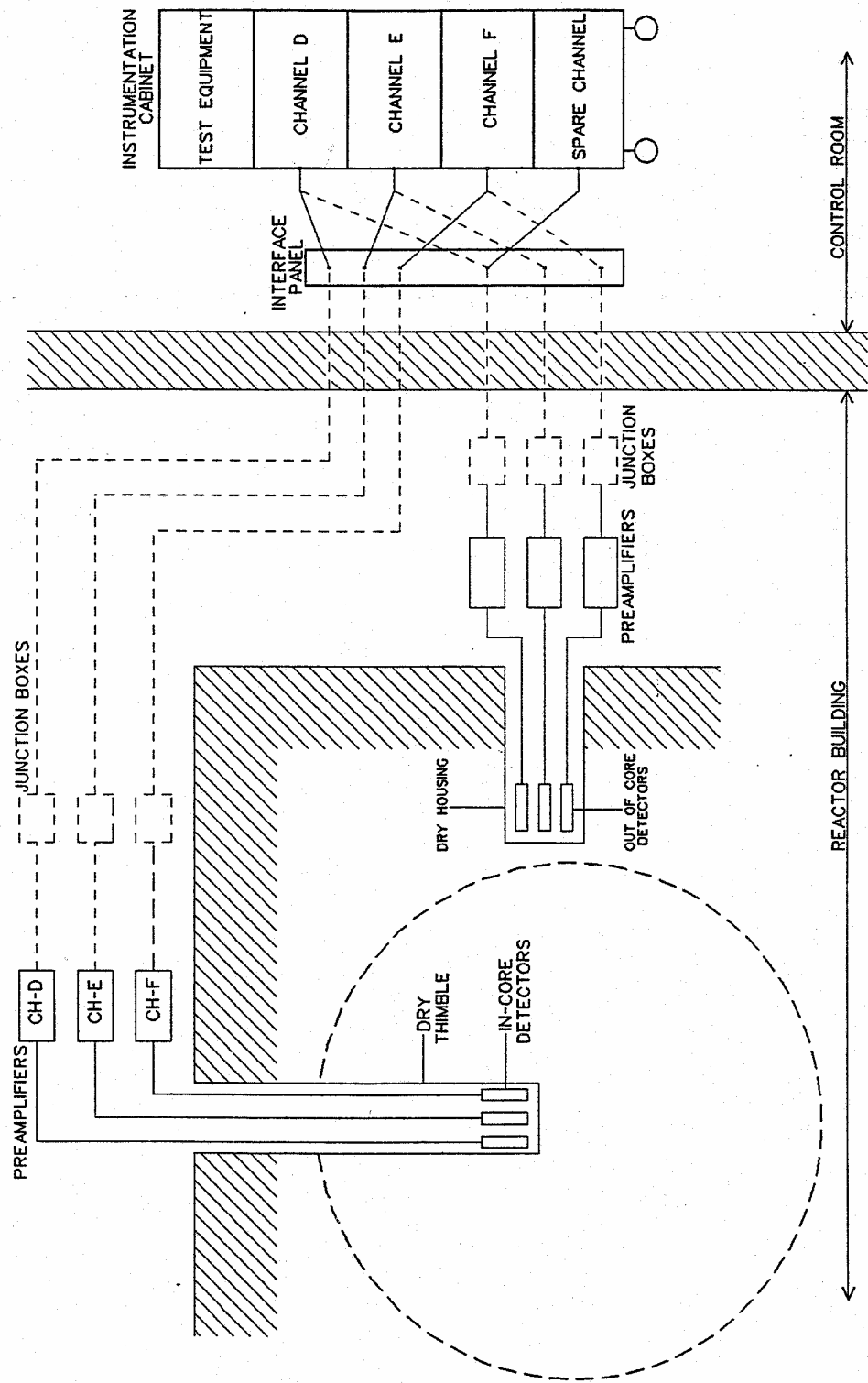

Figure 3.2. Arrangement of Startup Instrumentation.

Ion Chamber System

The ion chamber system is a part of the on-line power measurement equipment of the reactor control system. This instrumentation is on-scale during normal operation, and remains on-scale during a normal shutdown. If the shutdown lasts more than 40 to 70 days (depending on reactor operating history and ion chamber neutron and gamma sensitivity), the flux decays below 10^{-7} of the full power value and start-up neutron detectors are needed.

The ion chamber units consist of lead-shielded housings mounted on the outside of the calandria shell, in which ion chamber instruments and calibration shutters are installed. The lead attenuates gamma radiation so that the ion chambers measure neutron flux, primarily. The output current from separate ion chamber instruments is amplified to generate independent inputs for the reactor control system and each shutdown system, as follows:

- a. log neutron power, 10^{-7} to 1.5 full power,
- b. linear neutron power, 0 to 1.5 full power,
- c. rate of change of log power, -15 percent to +15 percent of present power per second.

Ion chambers measure only the average flux, as seen at the side of the core, but are sensitive to very low flux levels, for monitoring sub-critical as well as full power behavior. Because they are outside the calandria, the neutron flux they detect has been attenuated by the moderator and any poison dissolved in the moderator.

In-Core Flux Detectors

In-core flux detectors are used at high power levels (above 10 percent of full power) because they provide spatial information needed, at high power, to control xenon-induced flux tilts and to achieve the optimum flux distribution for maximum power output.

Vertical Flux Detector Assemblies

The control system flux detectors are of two types. One type has an Inconel emitter and is used for the zone control system. The other type has a vanadium emitter, and is used for the flux mapping system.

Both types of control system detectors, along with the Inconel detectors used for the shutdown system number 1 high neutron power trip, are contained in vertical flux detector assemblies located throughout the core. These assemblies extend from the reactivity mechanisms deck to the bottom of the reactor.

The assemblies are of the straight individually replaceable type with each detector housed in individual well tubes. There are 13 well tubes, 12 for detectors of various types and a central tube reserved for a potential traveling flux detector (for periodic detector recalibration).

The self-powered detectors are in the form of a coaxial, mineral-insulated cable. A lead cable portion joins the detector to a channelized, environmentally qualified connector on the deck. From there the signals are fed through twisted-pair shielded cables to amplifiers and multiplexer stations in the Group 1 instrumentation.

Zone Control Flux Detectors (Inconel)

The self-powered in-core flux detectors are installed in flux detector assemblies to measure local flux over two decades, 10^{-1} full power to 1.2 full power, in the regions associated with the liquid zone controllers. At each location there are two detectors for redundancy. An amplifier converts each detector current to a suitable input signal for the distributed control system.

These detectors have an Inconel emitter which provides a prompt response to a change in neutron flux. The control system transforms this response into a signal which closely matches corresponding changes in reactor power. The Inconel detectors have a relatively slow rate of burnup (loss of sensitivity due to accumulated exposure to neutron flux).

The zone control detectors and their amplifiers are grouped into two redundant channels and supplied by Class II power buses. Special measures are taken to avoid ground loops and noise pickup.

Flux Mapping Detectors (Vanadium)

The flux mapping system (described in Section 3.4) uses vanadium detectors distributed throughout the core to provide point measurements of the flux.

These detectors are almost totally neutron-sensitive; however, their response is delayed by 5.4 minutes due to the half-life of the beta emission from vanadium-52. The signals, approximately 3 μ A at full power, are fed to amplifiers in a stand alone distributed control system station inside the reactor building, where they are multiplexed and sent to the plant display system computer. The flux mapping instrumentation is powered by a Class II bus.

Fuel Channel Temperature Monitoring

The channel temperature monitoring system serves the following two functions:

- a. Channel flow verification: On startup, before boiling starts in the channels, channel outlet temperatures are calculated from channel powers provided by the flux mapping routine and estimated channel flows, and compared with the measured outlet temperatures. After the onset of boiling, the system only monitors the detectors for possible malfunctions.
- b. Power mapping validation: The channel temperature differentials are used with measured flows (instrumented channels) or predicted flows (other channels) to determine the estimated channel powers, which are then compared with the powers calculated from the flux mapping readings; this provides an ongoing validation of the accuracy of the flux-mapping channel powers.

The channel temperature monitoring system has resistance temperature detectors mounted on each of the outlet feeders. These detectors are externally mounted, thermally insulated from adjacent feeders, and have a reliable and secure mounting design to provide system sensitivity and reliability.

Since coolant boiling occurs at full power, the reactor power must be reduced somewhat for the channel temperature monitoring system measurements to be meaningful. Hence, channel flow verification is done while the reactor is returning to full power, especially if the heat transport system has been opened for maintenance purposes. In addition, several times a year, the reactor power is reduced to a level that results in zero quality in the coolant for channel flow verification and power-mapping validation.

Thermal Power Measurement

The fast, approximate estimate of reactor power is obtained by either taking the median ion chamber signal (at powers below 5 percent of full power) or the average of the in-core Inconel flux detectors (above 15 percent of full power) or a mixture of both (5 percent to 15 percent of full power). These signals are filtered and calibrated by comparison with estimates of reactor power based on thermal measurements from one of the following two sources:

- a. Several pairs of resistance temperature detectors are located on the reactor inlet and outlet headers. Each pair measures the temperature rise across the reactor. At power levels below the onset of coolant boiling in the fuel channels, the average temperature rise generates an accurate estimate of reactor power; this estimate is used to calibrate the Inconel flux detectors on-line below 50 percent of full power.
Reactor thermal power is directly proportional to average heat transport system coolant flow. The calculation of reactor power therefore requires an estimate of heat transport coolant flow. Since the reactor regulating program does not have access to heat transport system coolant flow measurements a constant value based on off-line calculations and commissioning measurements is used. In the power range of interest (below 50 percent of full power) there is no boiling and the heat transport system coolant flow does not vary significantly with power. A constant pre-calculated value is therefore adequate.
- b. At high reactor power, boiling commences in the fuel channels. With boiling in the fuel channels, the average temperature rise across the reactor fuel channels does not provide a good estimate of reactor power; flow variations also become significant. Therefore reactor power estimates above 70 percent of full power (for calibration purposes) are based on secondary side measurements. Steam flow, feedwater flow and feedwater temperature are measured and reactor power estimated from on-line enthalpy/flow calculations.

In the intermediate power range (50 percent - 70 percent of full power) a linear combination of the temperature differential measurements (used below 50 percent of full power) and the secondary side measurements (used above 70 percent of full power) are utilized as the calibrating signal. This assures a smooth and accurate transition.

3.3 REACTIVITY CONTROL DEVICES

Reactivity devices are provided to alter the rate of neutron multiplication (either as controllers or as shutdown devices). Control is provided for the following effects:

- Long-term bulk reactivity, mainly controlled by on-power fuelling.
- Small, frequent reactivity changes, both global and spatial-controlled by the liquid zone control system.
- Additional positive reactivity for xenon override and fuelling machine unavailability, mainly resulting from the withdrawal of adjusters.
- Additional negative reactivity for fast power reductions and to override the negative fuel temperature effect, provided by the insertion of mechanical control absorbers.
- Initial excess reactivity and decay of xenon following a long shutdown, compensated by moderator poison.

Because of on-power refueling and relatively small thermal hydraulic feedback effects, the flux shape, and hence the worth of reactivity devices, varies only marginally with power level and with time. In the following sections, the given reactivity worth of the various devices are typical nominal values and correspond to the reference adjuster design with the following core conditions: equilibrium fuelling, steady-state xenon, and full reactor power.

The reactivity control mechanism layout is shown in Figure 3.3. All reactivity control devices are located between rows of fuel channels, in the cool low pressure moderator.

Liquid Zone Control System

The zone control system is designed to perform two main functions:

- a. To provide short term reactivity control to maintain reactor power at the demanded level during normal operation (i.e. operating control of reactivity). This must be adequate for compensating the zero to full power reactivity change when equilibrium fuelling is achieved.
- b. To control spatial power distribution by suppressing regional power transients associated with space dependent reactivity perturbations. The dimensions of the CANDU 9 reactors are large in comparison to the thermal neutron diffusion length of the lattice and the reactor flux levels are high enough that the rate of burnup of xenon-135 is about 10 times its decay rate. These are sufficient conditions for xenon induced spatial power oscillations to occur and these must also be controlled.

For the purpose of spatial control, the reactor is divided into zones, as shown in Figure 3.4. Spatial control is obtained by means of light water zone control assemblies and associated thermal neutron detectors in each zone. The zone control assemblies consist of compartmentalized vertical Zircaloy tubes which traverse the core; as shown in Figure 3.5. Bulk reactivity control is achieved by varying the light water level in all compartments by the same proportion. Spatial flux control is achieved by differential adjustment of the light water level in individual compartments.

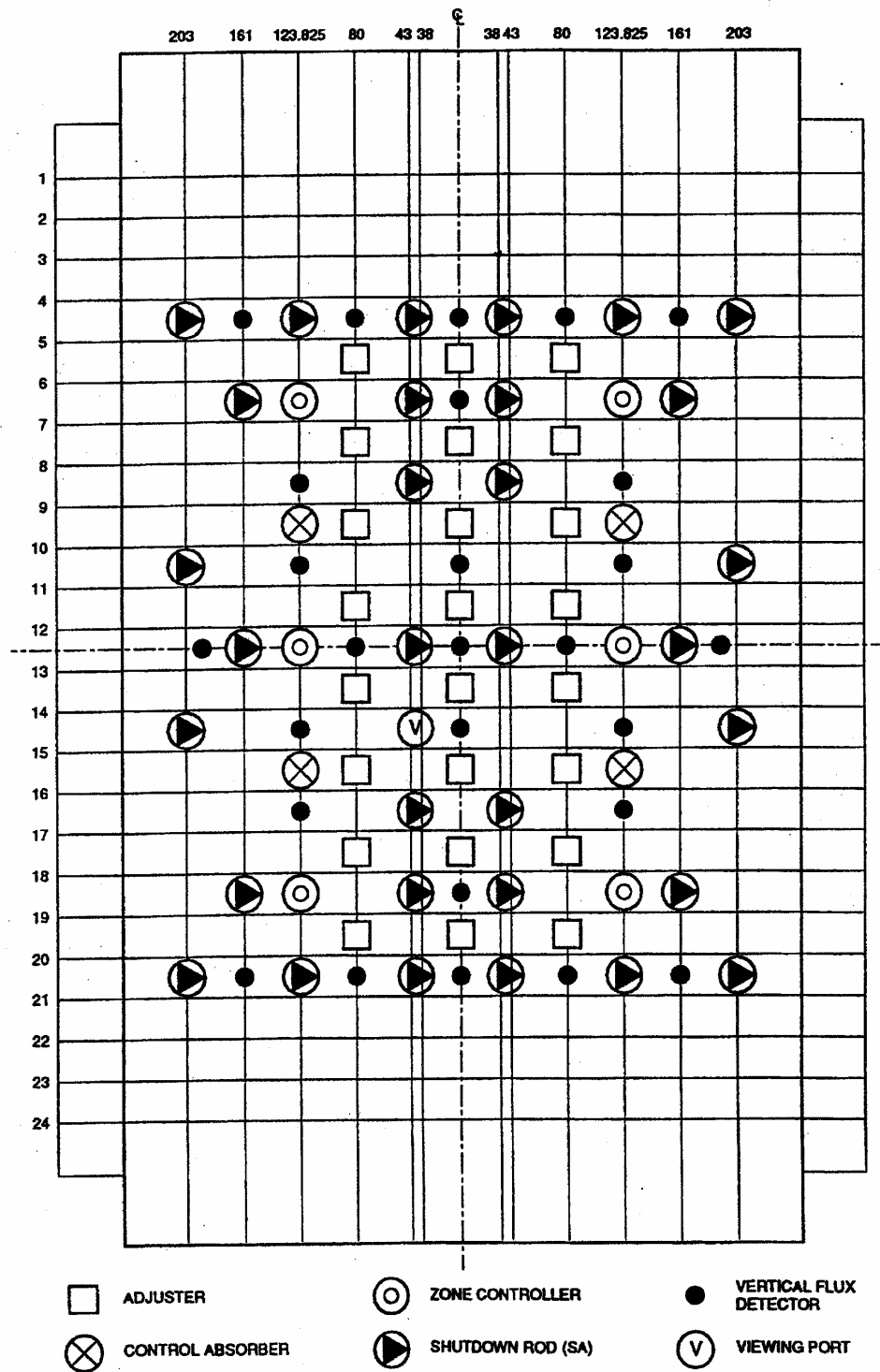
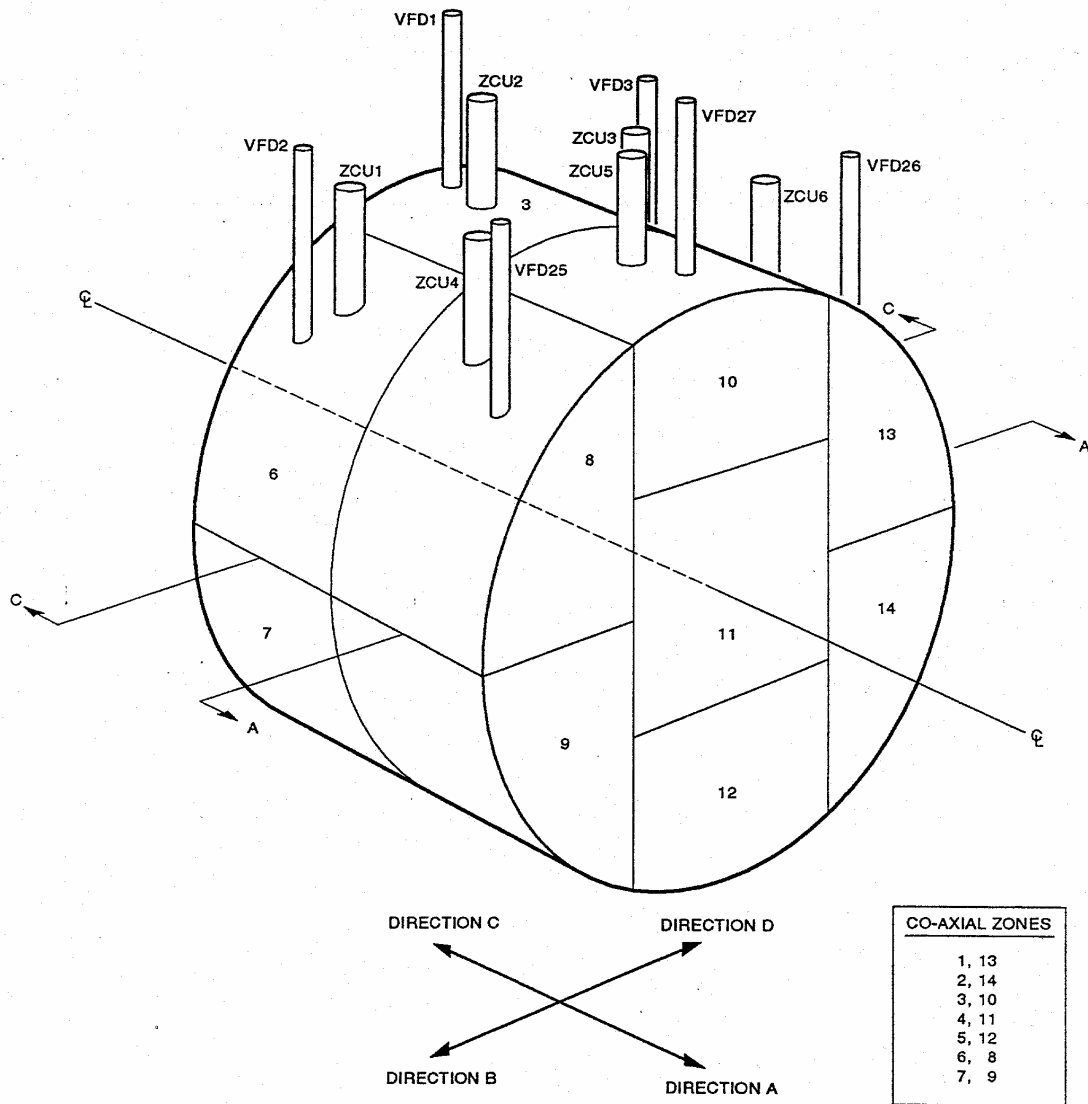

Figure 3.3. Reactivity Mechanism Layout.



950243-2

Figure 3.4. Relation of Zone Control Units to the Fourteen Zones and the Reactor Regulating Detector Assemblies (Vertical Flux Detectors) 1, 2, 3, 25, 26, 27.

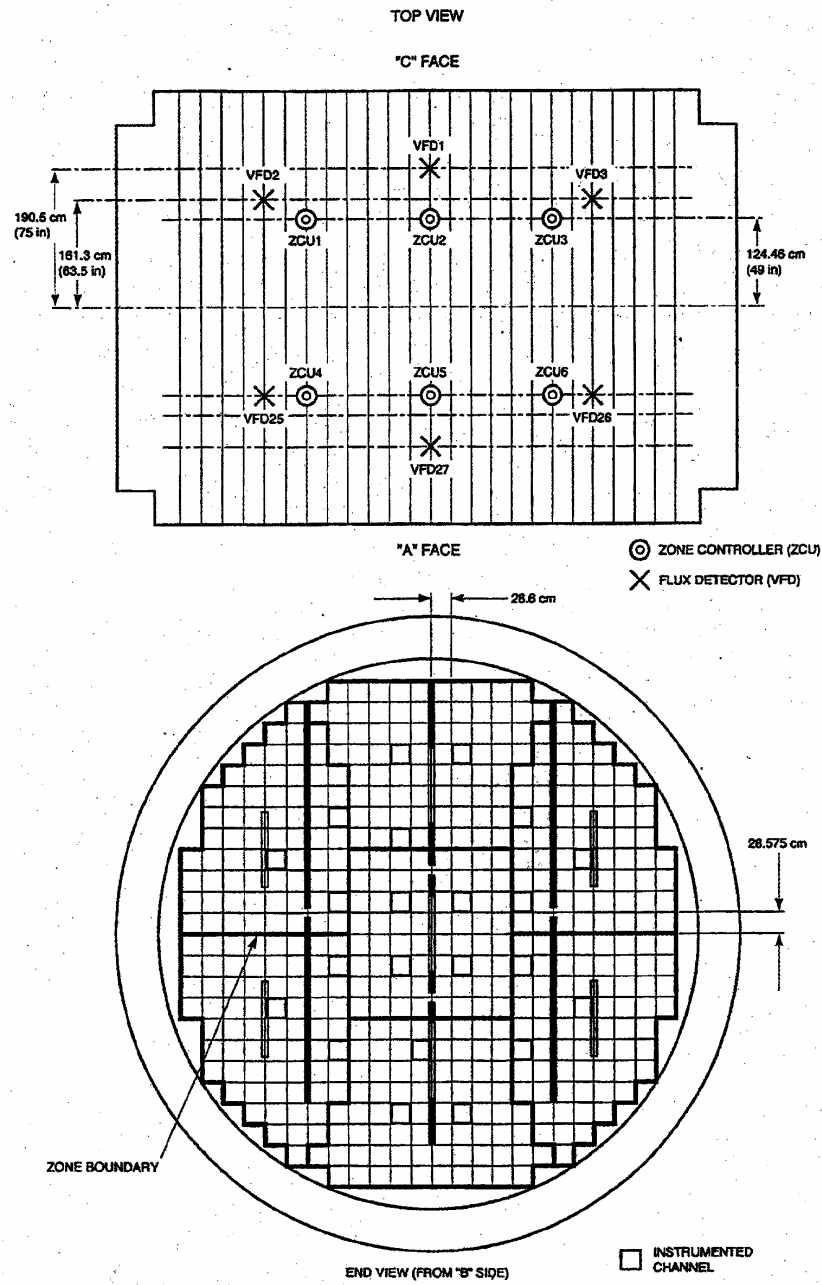

Figure 3.5. Zone Control Absorbers and their Associated Flux Detectors.

The total reactivity worth of the liquid zone control system from empty to full is -8.2 mk for the fresh initial core, and -7.2 mk for the equilibrium core using the homogeneous model. The difference in the liquid zone control system reactivity worth in the two states is mainly due to the difference in core flux distributions.

Table 3.1 gives the reactivity worth of the liquid zone control system for the CANDU 9 equilibrium core as a function of the average percentage fill. In the nominal operating range of between 20 percent and 70 percent fill, the worth of the liquid zone control system is essentially proportional to the average level; the corresponding reactivity coefficient is -0.077 mk/percent of fill.

Table 3.1. Variation of Zone Control System Reactivity Worth with Average Zone Level (Equilibrium Core Homogeneous Model).

Average Zone Level (% Fill)	Zone Control System Reactivity (mk)
0	0
10	0.86
20	1.70
30	2.53
40	3.34
50	4.12
60	4.87
70	5.56
80	6.17
90	6.73
100	7.19

A simplified flowsheet for the liquid zone control system is presented in Figure 3.6. A typical liquid zone control unit is shown in Figure 3.7.

The system consists of two subsystems; one for demineralized water circulation and one for gas circulation. With the exception of the delay tank and helium storage tank, the system equipment is located in an area of the reactor building which is accessible during operation.

The demineralized water subsystem is a closed circuit consisting of three 100 percent centrifugal pumps, a 100 percent tube and shell heat exchanger, a delay tank, two ion exchange columns, supply and return headers, pneumatic control valves and interconnecting piping and tubing, which connects to each liquid zone compartment via supply and drain lines.

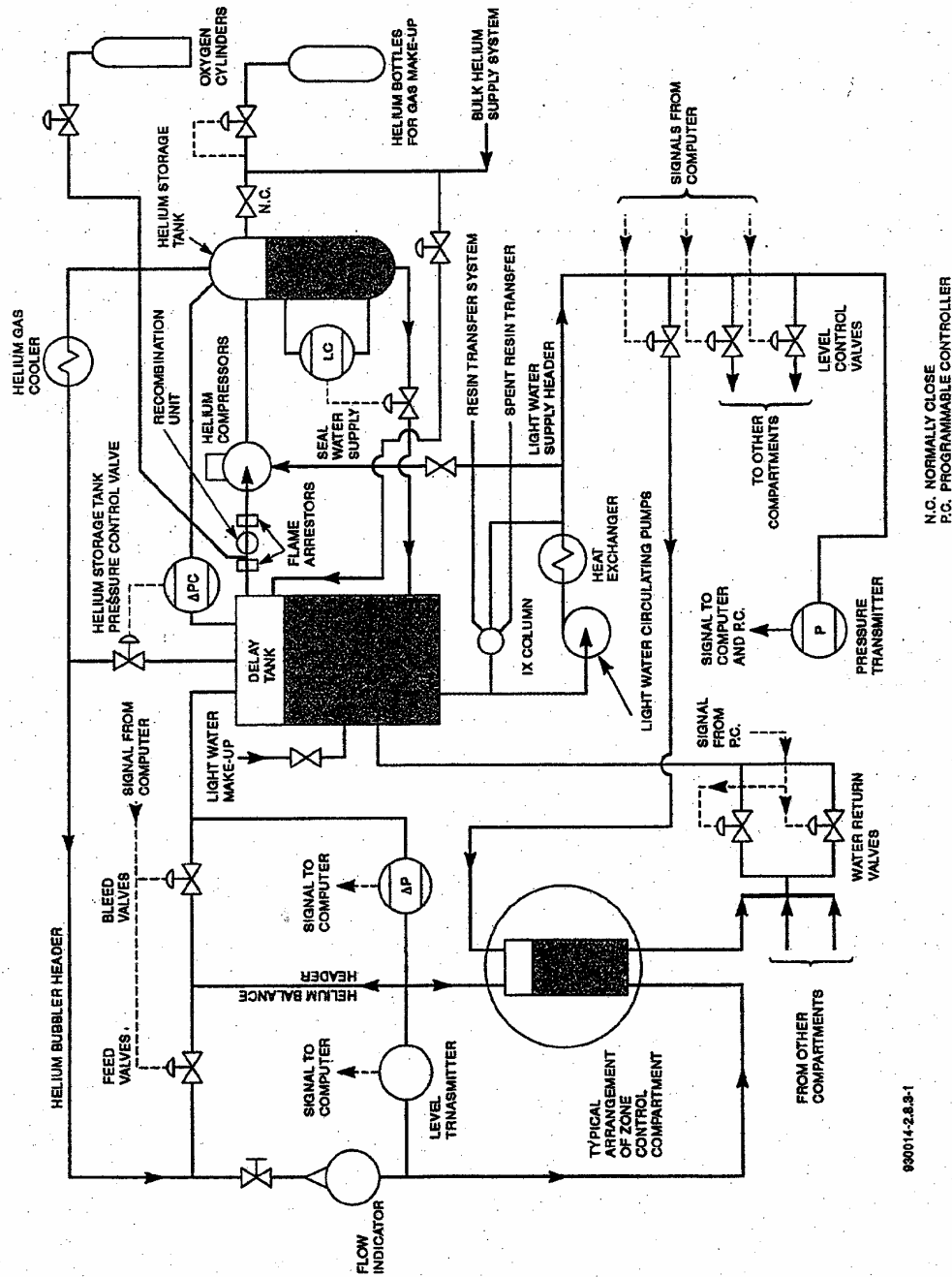

Figure 3.6. Liquid Zone Control Flow Diagram.

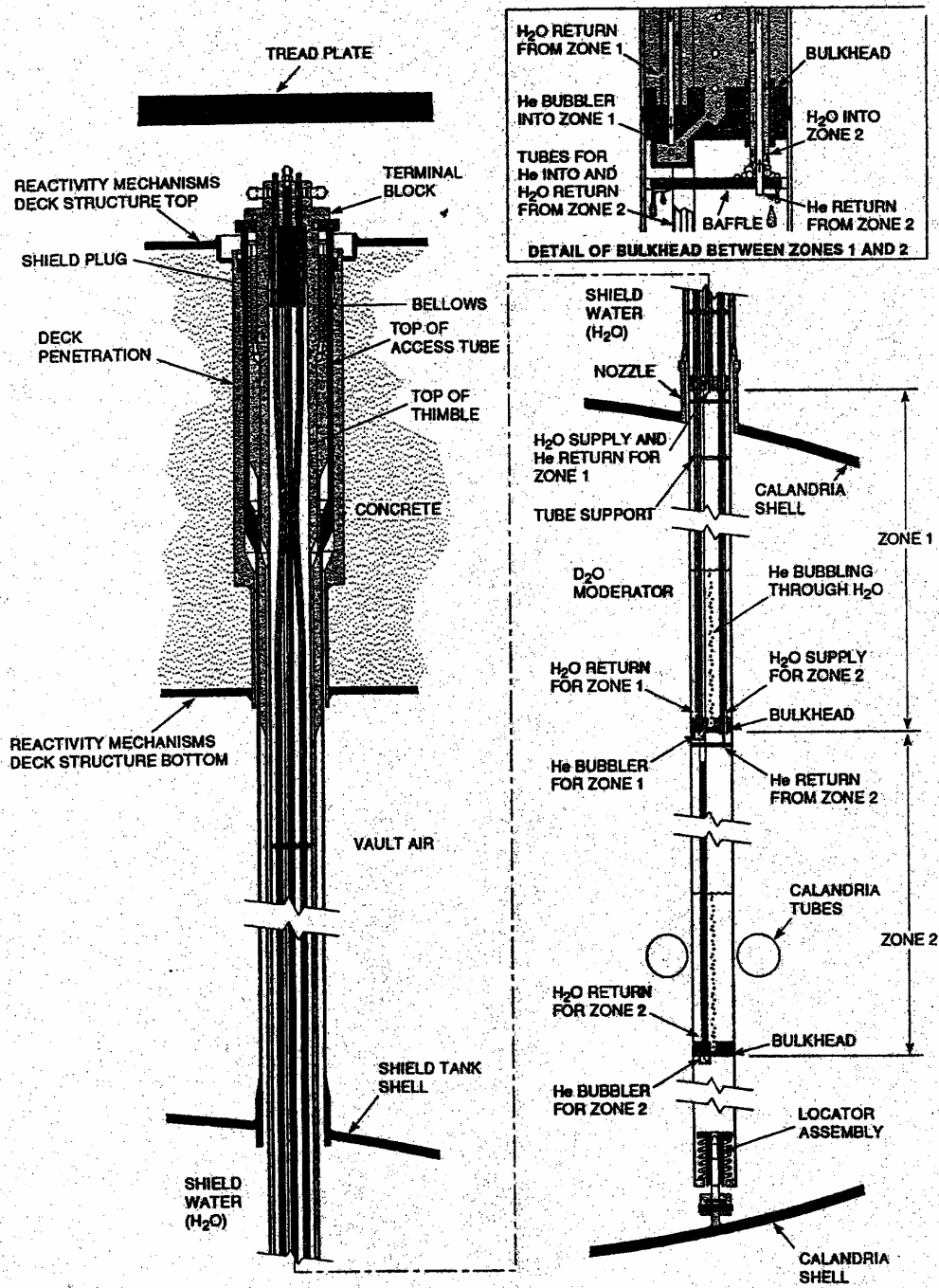

Figure 3.7. Liquid Zone Control Unit (2 Zone).

A constant outflow of water from each liquid zone compartment permits the quantity of water in the compartment to be controlled by varying the rate of inflow. The outflow from the liquid zone control compartments is discharged to the delay tank through the return header. The delay tank is used for the decay of short lived neutron activation products before they enter the accessible area of the reactor building. The delay tank also functions as a water storage tank.

The delay tank is connected to the suction of three centrifugal pumps, one of which normally operates with the other two on standby. The pumps are driven by electric motors connected to the Class IV power supply. The discharge from the pumps supplies water to the compartments, through individual control valves and also supplies seal water to the two compressors. A portion of the pump discharge flows to the ion exchange columns for removal of ionic and suspended particles.

The helium subsystem is a closed circuit, consisting of two liquid ring type compressors, a storage tank, two flame arrestors, a pre-heater, a recombination unit, a balance header pneumatic control valve train and interconnecting pipe and tubing which connects to each liquid zone compartment via supply and return lines.

Helium is used as the cover gas because it is chemically inert and does not become activated. The helium for the liquid zone control system is supplied from the bulk helium supply system. A back up helium supply is provided from cylinders.

The compressors maintain pressure in the helium storage tank and supply gas to bubblers in each of the compartments and to the helium balance header. The helium storage tank pressure is kept constant and higher than that of the delay tank by means of control valves. The helium feed and bleed valves control the gas pressure in the compartments. The feed valves open as the pressure decreases when the water inventory in the compartments decreases and the bleed valves open as the pressure increases when the water inventory increases. The bleed valves return the helium to the delay tank.

A catalytic recombination unit upstream of the compressors reduces the concentration of radiolytic hydrogen in the helium to acceptable limits. The recombination unit uses palladium as a catalyst and is capable of operating at a high temperature without damage.

Oxygen is added manually from cylinders when required to facilitate recombination. Flame arrestors are provided at the inlet and outlet of the recombination unit.

The helium balance header pressure is controlled by feeding helium from the storage tank into the header or by bleeding excess helium from the helium balance header into the delay tank. The pressure difference between the delay tank and the helium balance header is used to control the feed and bleed valves.

The helium balance header triplicated differential pressure transmitters provide measurement signals to the computers in the distributed control system, which compute feed and bleed valve lifts to maintain a fixed differential between the helium balance header and the delay tank. One pair of feed and bleed valves is used for primary control while the second pair provide backup operation should the primary valves fail.

Adjuster Rods

The adjuster rods are provided to shape the neutron flux for optimum reactor power and fuel burnup, and to supply positive reactivity beyond the normal control range of the zone controllers when required.

The adjusters are arranged in rows, as shown in Figure 3.3. The rods are normally fully inserted in the core, and their movements are controlled in banks. The maximum total reactivity which may be gained on withdrawal of all adjuster rods is about -16 mk. This is sufficient to compensate for the negative xenon reactivity at 35 minutes after a shutdown from full power (during fresh fuel conditions the adjuster worth is somewhat less than -16 mk; however, the xenon override capability is not significantly affected).

The operation of the adjusters is normally controlled by the reactor regulating system, but can also be manually operated under prescribed conditions. The maximum reactivity change rate of any one bank of adjusters is ± 0.07 mk/s.

Mechanical Control Absorbers

The mechanical control absorbers are normally poised out of the core, and are driven in by the reactor control system to supplement the negative reactivity of the liquid zone control units, or dropped to effect a fast reactor power reduction (stepback). They can be driven into or out of the reactor core, at variable speed, or dropped by releasing their clutches. When dropped, the elements are fully inserted in three seconds. By re-energizing the clutch while the elements are dropping, a partial insertion to any intermediate position can be achieved.

The maximum total reactivity worth of the mechanical control absorbers is about -11.0 mk in the initial core and -9.4 mk in the equilibrium core. These absorbers consist of tubes of cadmium sandwiched between stainless steel. Their arrangement is shown in Figure 3.3.

Moderator Poison

Moderator poison is used to reduce excess reactivity during fresh fuel conditions or during shutdown to compensate for xenon decay. Boron is used in the former situation and gadolinium in the latter situation. The burnout rate of gadolinium on a subsequent startup is comparable to the xenon growth rate, hence smooth control is possible when gadolinium is used for this purpose (this poison addition system is independent of the liquid poison injection system used as a shutdown system).

The design rate of poison addition is equivalent to -0.75 mk/min. Removal rates depend on poison concentration. At a poison level of -30 mk, the removal rate is approximately +0.05 mk/min.

3.4 REACTOR REGULATING SYSTEM PROGRAMS

A block diagram of the reactor regulating system is shown in Figure 3.8. Some logic blocks are shown only for convenience and do not necessarily imply separate, self-contained programs. The functions of each program logic block are discussed in detail below.

The regulating system is characterized by a high degree of immunity to small process upsets, and measurement failures, by redundancy in control devices and process measurements. Extensive checks are performed in the programs to ensure that faulty signals are discarded. In case of loss of a signal or an entire set of signals, alternative measurements are used. In case of failure of a control device, a backup is used. However, it may be necessary to derate the reactor because of limited information or imperfect flux shape.

This ability to maintain control in the presence of partial system failures, combined with the high reliability of the distributed control system, leads to a very high availability of the reactor control system.

Power Measurement and Calibration

The regulating system controls bulk reactor flux level and flux shape, by increasing or reducing the level of the light water in the zone controllers to equalize and/or change the powers in the power zones of the core. Spatial flux control is required to prevent xenon-induced instabilities and other space dependent perturbations.

Total reactor power is determined by a combination of ion chamber signals (at low power) and Inconel zone detector signals (at high power). The crossover occurs around 10 percent of full power. Because neither measurement is absolute, the flux signals are continuously calibrated against reactor power measurements based on thermal signals.

The zone power measurements are based on the Inconel flux detectors. Absolute measurements are less important here because the spatial control system acts to equalize the measurements. However, a single flux measurement may not be exactly representative of average power in a region of the core because of local flux disturbances such as refueling. Therefore, the Inconel detector signals are calibrated continuously using the flux mapping routine.

Flux Mapping Routine

The flux mapping routine collects readings from the Vanadium flux detectors distributed throughout the reactor core and computes a best fit of this data with respect to flux modes expected for the given core configuration. Flux mapping provides an accurate estimate of average zone flux in each of the power zones. These estimates are available once every two minutes and lag the neutron flux by approximately five minutes, the Vanadium detector time constant. Spatial calibration in a zone is done by matching the average zone flux estimate generated by flux mapping with appropriately filtered zone Inconel flux detector readings. The flux mapping routine rejects individual detectors whose readings disagree with the rest of the detectors. The net result is a smoothed accurate steady state estimate of relative zone power.

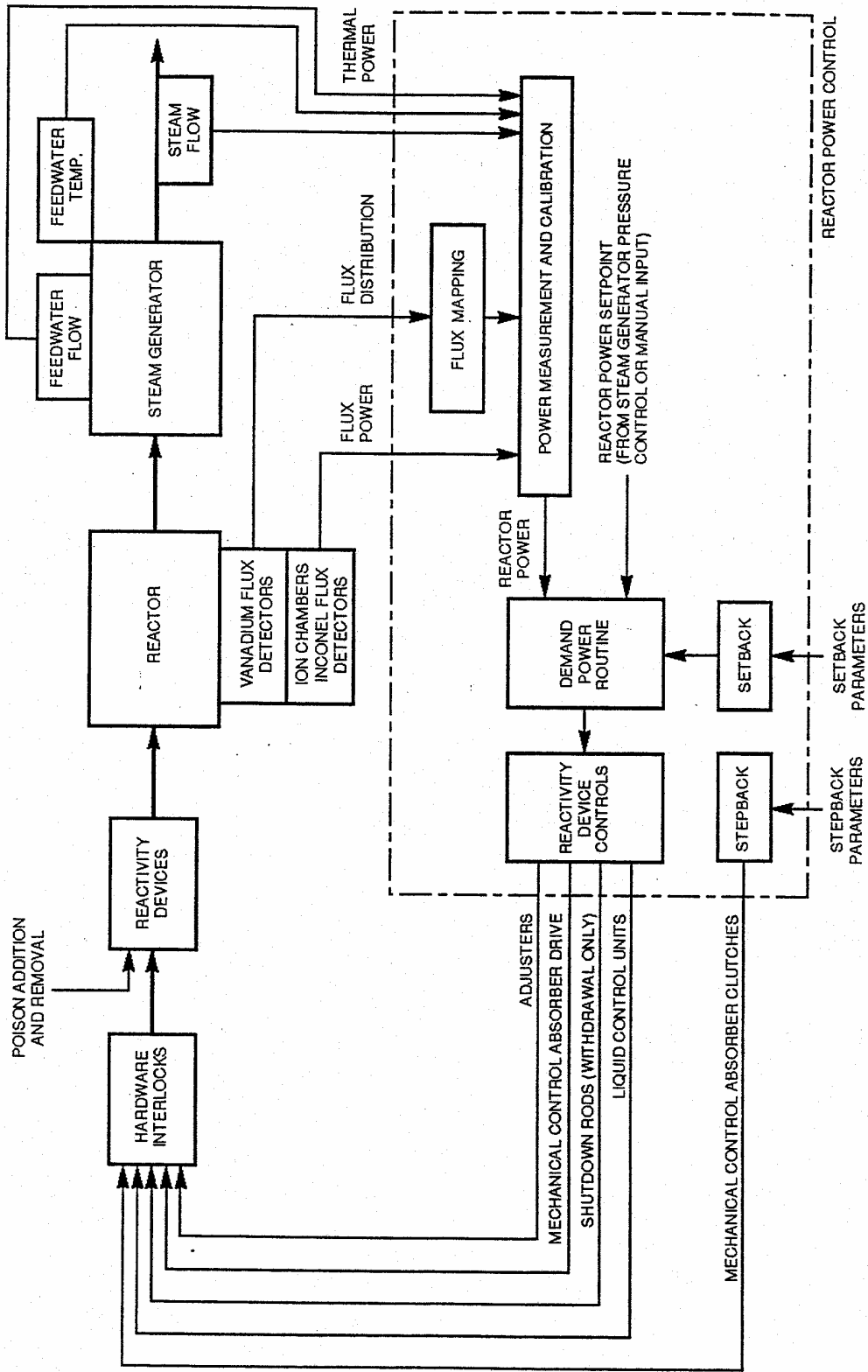

890014 2/18-11

Figure 3.8. Reactor Regulating System-Block Diagram.

Demand Power Routine

The demand power routine generates the reactor power setpoint on the basis of demands from three sources:

- a. the steam generator pressure control program (normal mode),
- b. the operator (alternate mode),
- c. the setback routine.

Normally at high power the steam generator pressure control program dictates reactor power changes to give a reactor-follows-turbine type of control.

At low power, during upset conditions or at the operator's discretion, the reactor power setpoint is under manual control via the keyboard.

Setbacks override both of the above modes to ensure that reactor power is reduced when selected plant parameters exceed acceptable operating limits.

All reactor power setpoint changes are limited by the control program to safe rates and safe upper limits. A deviation limiter prevents the power setpoint from being more than 5% above the actual power to preclude the possibility of a large power increase at excessive rates.

Reactivity Mechanism Control

The reactivity mechanism control logic is summarized in Figure 3.9. The primary method of short-term reactivity control is by varying the liquid level in the zone controllers. Normally, the adjusters are fully inserted, the control absorbers are fully withdrawn and the average liquid zone control compartment level is between 30 percent and 50 percent. The total control signal to the zone control valves consists of the bulk power control term plus a differential component proportional to that zone's power error.

In case of a shortage of negative reactivity, indicated by a high zone controller level or a positive power error, the mechanical control absorbers are driven in, one bank at a time.

In case of a shortage of positive reactivity, indicated by a low zone controller level or a negative power error, the adjusters are driven out in a specific sequence.

The adjusters and mechanical control absorbers are driven at a speed proportional to power error to minimize, at low power errors, the shim reactivity rate which must be canceled by the zone controllers.

The program also automatically withdraws all the shutdown rods unless: all rods are fully out, the reactor is tripped, the power error is too large, mechanical control absorbers are not in the core or the measured lograte is too large.

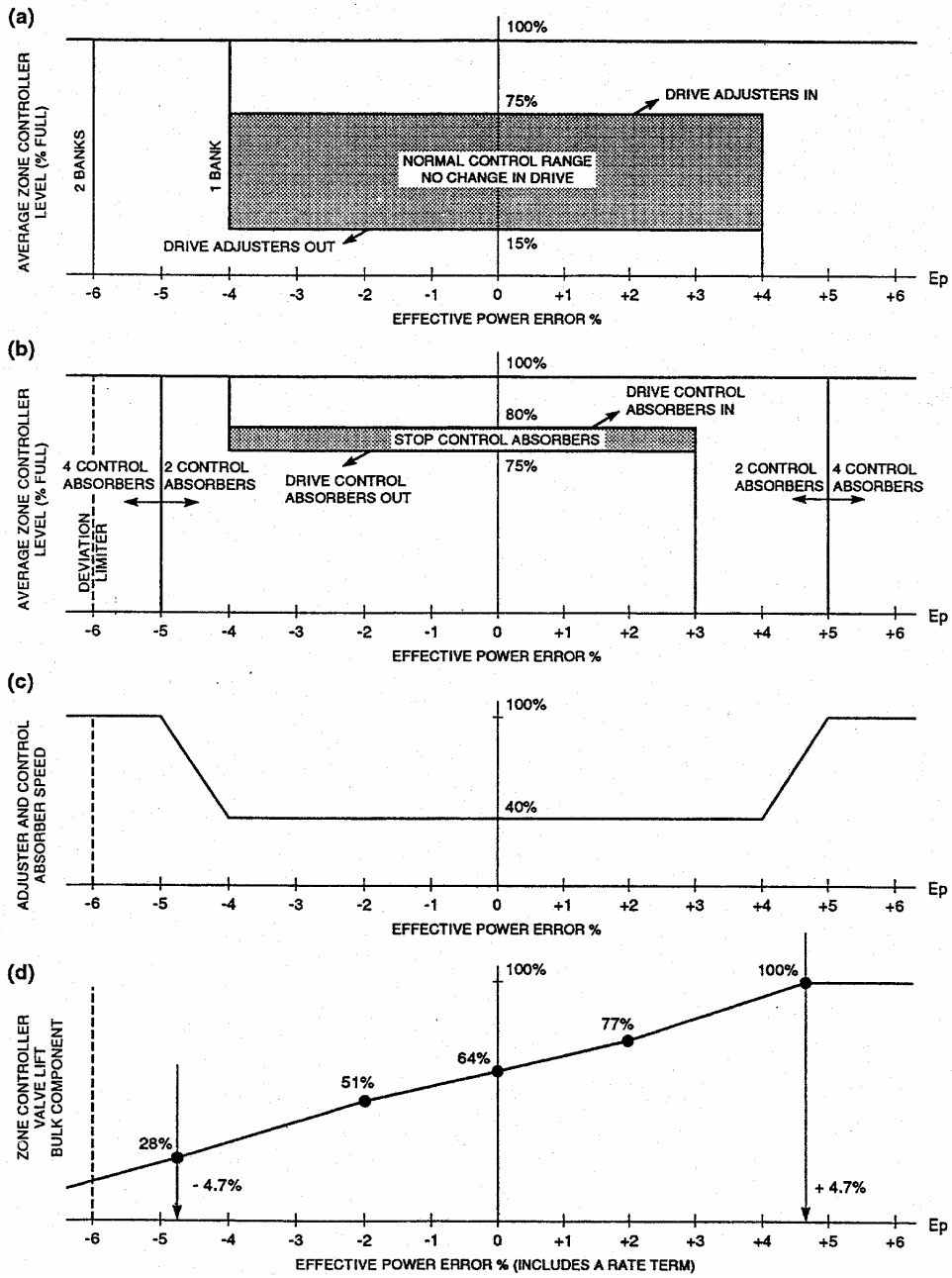

Figure 3.9. Reactivity Limit Control Logic Diagram.

Setback Routine

The setback routine monitors a number of plant parameters and reduces reactor power promptly in a ramp fashion if any parameter exceeds specified operating limits. The rate at which reactor power is reduced and the power level at which the setback ends will be appropriate for each parameter. Typical conditions leading to setbacks are listed in Table 3.2.

The setback overrides other reactor power demands and is accompanied by alarm window annunciation.

Table 3.2 Typical Setback System Conditions

Conditions	Setback Rate (percent per second)	End Point (percent of Full Power)
Zone Control System Failure	0.2	60
Spatial Control Off Normal	0.1	-
Zone power > 110 percent at full power	-	60
Flux tilt >20 percent above 60 percent full power	-	20
Flux tilt >40 percent between 20 percent and 40 percent full power	-	20
High Local Neutron Flux	0.1	60
High Steam Generator Pressure	0.5	10
Low Deaerator Level	0.8	2
High Moderator Level	0.8	2
Turbine Trip or Loss of Line	0.8	60
Endshield Flow	0.8	2
Endshield Temperature	0.8	2
Sustained Low Condenser Hot Well Level	0.8	2
Manual	0.5	2

Stepback Routine

The stepback routine also reduces reactor power, but instead of reducing reactor power gradually like the setback routine, it drops the mechanical control absorbers either fully or partly into the reactor, causing a sudden power reduction. Typical plant upsets causing stepbacks are summarized in Table 3.3.

Table 3.3 Typical Stepback System Conditions

Conditions	Control Absorber Response
Reactor Trip	Full rod drop
2/3 contacts on SDS1 or SDS2	
All Heat Transport Pumps Trip	Full rod drop
Single pump trip	Full rod drop
Trip of two pumps at same end of reactor	Full rod drop
Heat Transport High Reactor Outlet	Full rod drop
Header pressure and	
reactor power > 1 percent full power	
High Zone Power	Full rod drop
High Rate of Log Neutron Power	Full rod drop
Low Moderator Level	Full rod drop
Low Steam Generator Level	Full rod drop

Control Logic for the Reactivity Mechanisms

This logic functions as an interface with the power circuits of the motor control centers and the clutch coils of the mechanical shutdown units and mechanical control absorber units. This logic incorporates interlocks to limit the consequences of a gross loss of regulation.

Adjuster Control Logic

A block diagram of the system is shown in Figure 3.10. It incorporates ‘in’ drive logic, ‘out’ drive logic, element position indication, end stop logic, manual controls and interlocks.

The logic allows the operator to select either the automatic or the manual mode of adjuster control. The logic stops the drive motor when the element is fully in or fully out (end stop), as determined by the signal from one of the two potentiometers on the mechanism. The logic inhibits the 'out' drive if either or both of the shutdown systems are not poised and overrides any attempt made to withdraw, simultaneously, more than a specified number of adjusters from the core. This limits the potential rate of reactivity addition; however, this rate interlock and the end stops can be bypassed, if the ‘emergency manual’ mode is selected by the operator.

The logic provides the operator with information on the status of the system and generates alarm signals if faults occur (e.g., motor trouble, too many adjusters driving out).

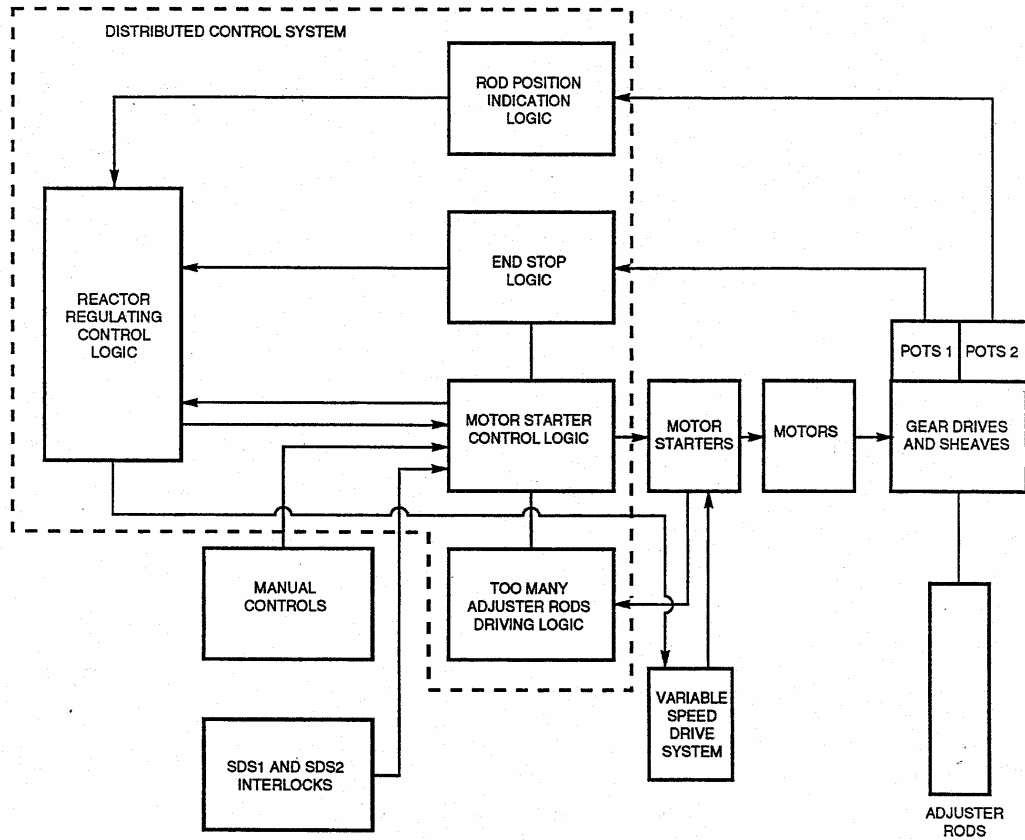

930044-2.18-14

Figure 3.10. Block Diagram of the Adjuster Control System.

Mechanical Control Absorber Control Logic

This logic is similar to that of the adjusters, but includes power supplies and control circuits for the clutches. The clutches allow the mechanical control absorber elements to be dropped into the core to achieve a fast power reduction (stepback).

The mechanical control absorber logic allows the operator to select either the automatic or the manual mode of mechanical control absorber drive.

The logic stops the drive motor when the element is fully in or fully out, as determined by the signal from the potentiometer on the mechanisms. The drive motor is inhibited if either or both of the shutdown systems are not poised. The logic over-rides any 'out' drive command if the 'in' drive is requested. The status of the system is displayed and alarm signals are generated if faults occur.

The clutch control circuit drops the mechanical control absorber elements when a stepback is demanded. The clutches can be re-energized during the drop to terminate the stepback at an intermediate power level.

Two clutch power supplies, fed from different buses, are provided to ensure that failure of one supply does not initiate a stepback. The units are set at different voltages, 90 and 93 V direct current. They provide supply power through diodes, so that the 90 V unit is on "hot" standby.

The instrumentation permits the operator to perform a partial drop test on the rods. The duration of the test is controlled by an adjustable time delay. Software test circuits are also provided.

Shutdown Rod Withdrawal Logic

Dropping of the shutdown rods is controlled by shutdown system number 1. However, withdrawal of the rods is controlled by the regulating system. Withdrawal is inhibited until the shutdown signal is cleared. The design of this logic is similar to that for the adjuster and mechanical control absorber rods, except that constant speed drive is used. The logic counts the number of shutdown rods withdrawn to determine when shutdown system number 1 is poised.

For withdrawal, the shutdown rods are arranged in two banks. For normal withdrawal, controlled by the reactor regulating system, both banks are withdrawn simultaneously, with withdrawal being stopped if the power error or the rate log power change exceeds a specified limit. Manual withdrawal is by separate banks and is allowed only if computer control is unavailable. The operator may also select individual rods to be driven in or out under manual control. Analog rod position signals are provided from potentiometers on the mechanisms for all shutdown rods to the distributed control system.

Speed Control System for the Reactivity Mechanisms

Variable speed control is provided to drive the adjuster and mechanical control absorber elements into or out of the core. Each mechanism has a reliable, three-phase induction motor whose speed is controlled by varying the frequency of the input power. This is done by means of a variable frequency inverter which functions as a voltage-controlled oscillator over the range from 12 to 60 Hz. It is powered from redundant, three-phase, Class III buses. If bus C fails, the system can be switched to bus A. Operation without variable speed control is satisfactory for the time necessary to repair or replace the inverter. A manually controlled contactor bypasses the variable frequency inverter and supplies all induction motors with line frequency power.

Dedicated reversing motor starters control the elements individually. Speed, normally on automatic control, can be manually set from the main control room. A manual speed setting will also apply to the automatic control of adjusters and mechanical control absorbers. The main control panel also annunciates major failures of the system.

Hardware Interlocks

The automatic control of the reactivity mechanisms is subject to a number of interlocks to limit the consequences of a gross loss of regulation.

To prevent the reactor from being started up with the safety systems unavailable, the adjusters and mechanical control absorbers are inhibited from being withdrawn unless both shutdown systems are poised.

The adjusters are further interlocked to prevent more than a certain number of rods from being withdrawn at the same time. This limits the maximum rate of addition of positive reactivity. Another interlock is provided which prevents the reactor from coming critical on shutdown rod withdrawal. It prevents the shutdown rods from being withdrawn unless the mechanical control absorbers are in the core.

Copyright information for Chapter 3:

Figures on pages 3-5, 3-7, 3-12, 3-13, 3-14, 3-16, 3-17, 3-21, 3-23 and 3-26 are from CANDU® 9 480/NU Technical Description, AECL document 69-01371-TED-001 Rev. 1, January 1995. Reprinted with permission of Atomic Energy of Canada Limited (AECL).

CHAPTER 4

HEAT TRANSPORT

CHAPTER OBJECTIVES:

At the end of this chapter, you will be able to describe the following features of the CANDU heat transport systems:

1. The functions of the main or primary heat transport system, the pressure and inventory control system, and the shutdown cooling system;
2. The layout and major components of the main circuit;
3. The major components and operation of the pressure and inventory control system;
4. The equipment and operation of the shutdown cooling system;
5. The main operating characteristics of the heat transport system.

The heat transport system is the first main link in the process of transferring the energy released from fission to electricity. It also has key safety functions in assuring constant cooling of the fuel, as well as forming one of the containment barriers against fission product release. Along with reactor core calculations, the response of the heat transport system under abnormal and accident conditions has been the subject of extensive research and analysis.

This chapter describes the functions, features, equipment and operation of the main (or primary) heat transport system, the pressure and inventory control system, the shutdown cooling system, and auxiliary systems that deal with heat transport purification and heat transport heavy water collection.

The Emergency Core Cooling System that operates to assure cooling of the fuel during a loss of coolant accident will be discussed in Chapter 6.

4.1 MAIN HEAT TRANSPORT SYSTEM

The main (or primary) heat transport system circulates pressurized heavy water coolant through the reactor fuel channels to remove heat produced by fission of natural uranium fuel. The heat is carried by the reactor coolant to the steam generators where it is transferred to light water to produce steam, which subsequently drives the turbine-generator. A schematic flow diagram for the heat transport system and its auxiliary systems is shown in Figure 4.1.

The main functions and features of the heat transport systems are as follows:

- Transports heat produced by the fission of natural uranium fuel in the reactor fuel channels to the steam generators, where the heat is transferred to light water to produce steam.
 - Provides cooling of the reactor fuel at all times during reactor operation and provide for the coolant to remove decay heat when the reactor is shut down.
 - Each heat transport pump has sufficient rotational inertia so that the rate of coolant flow reduction matches the rate of power reduction following the reactor trip if power to the pump motor is lost.
 - A shutdown cooling system is provided to remove reactor decay heat following shutdown. This system permits the draining of the heat transport pumps and the primary side of the steam generators for maintenance.
 - Allows decay heat removal by natural circulation under total loss of pumping power.
 - Limits the effect of postulated loss-of-coolant accidents to within the capability of the safety systems and provide a path for emergency coolant flow to the reactor fuel in the event of such an accident.
 - Heat transport system pressure is controlled for all normal modes of operation, and overpressure protection is provided by instrumented relief valves and reactor regulating and/or safety shutdown system action.
 - Contains the heat transport system heavy water inventory with minimum leaking or downgrading.
 - Provides containment for fission products that may be released from defected fuel during normal operating conditions.
 - Potential heavy water leak sources (such as at valves and mechanical joints) are kept to a minimum by using welded construction wherever practicable. Where potential leak sources exist, they are connected to closed collection and recovery systems.
 - Purification by filtering, ion exchange and degassing is provided to control the chemistry of the reactor coolant.
 - Provides process measurements for tripping and shutting down the reactor to ensure that system pressure is within allowable limits.
 - Provides process measurements for detection of loss-of-coolant conditions and initiation of emergency core coolant injection, in conjunction with other process signals.
 - The heat transport system is seismically qualified to the design basis earthquake. Auxiliary systems which form part of the heat transport system boundary are also seismically qualified. These include the shutdown cooling system, part of the pump seal system and part of the pressure and inventory control system.
-

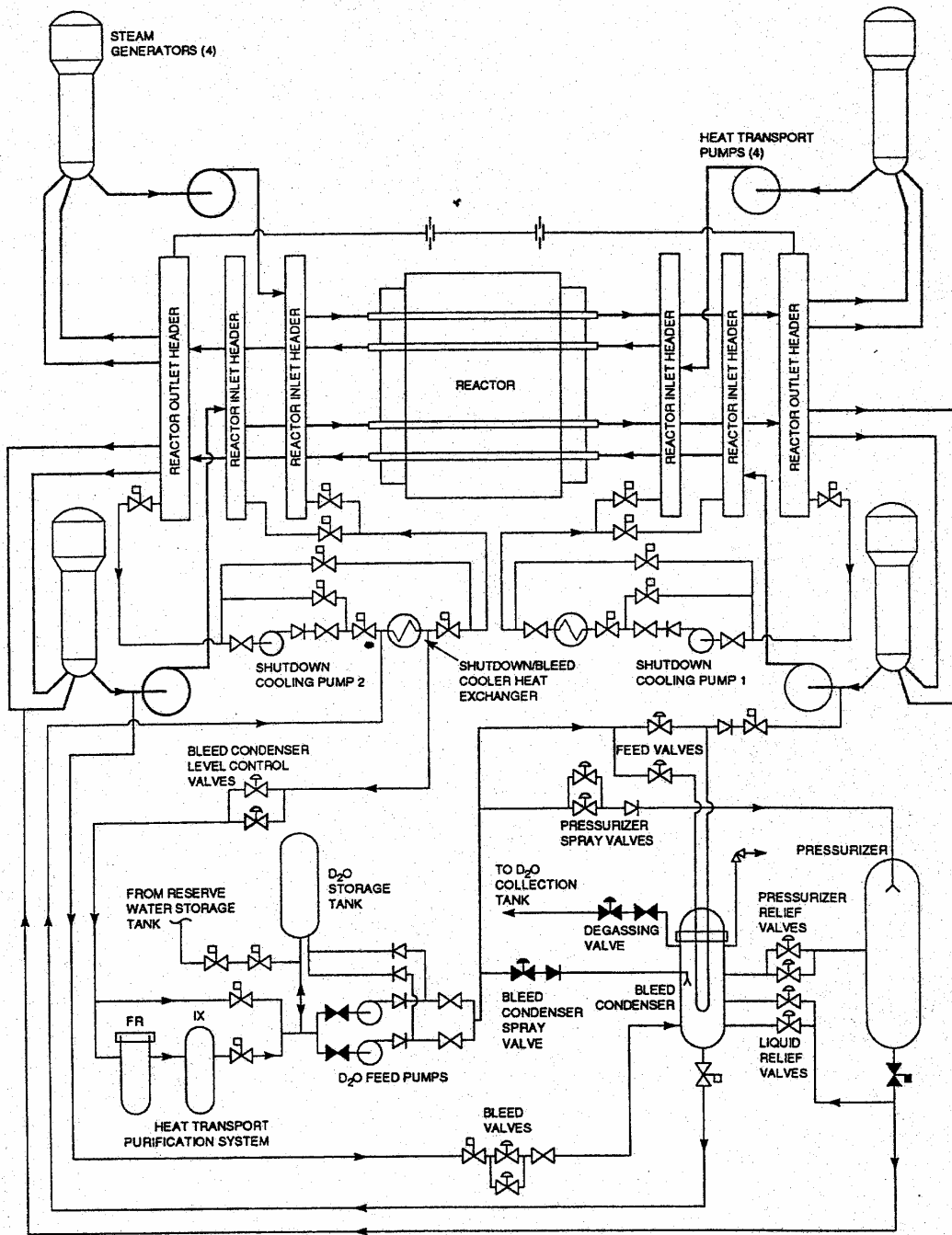

Figure 4.1. Heat Transport Systems Simplified Composite Flow Diagram.

The major components of the heat transport system are the reactor fuel channels, four vertical steam generators, four motor-driven pumps, four reactor inlet headers, two reactor outlet headers and the interconnecting piping.

The reactor coolant outlet of each steam generator is connected to one heat transport pump by a pump suction line. Each pump has one discharge pipe, connected to a reactor inlet header which supplies flow to the fuel channels in one quarter of the reactor fuel channels via individual inlet feeders. Each steam generator has two reactor coolant inlet pipes connected to a reactor outlet header which receives flow from the fuel channels via individual outlet feeders. Adjacent channels are alternatively connected to separate inlet and outlet headers by means of inlet and outlet feeders. The complete circuit forms a figure-of-eight loop, as can be seen from Figure 4.1.

The reactor outlet headers are interconnected by a relatively small pipe with an orifice to assure system thermohydraulic stability.

Four identical steam generators using inverted vertical U-tube bundles in a shell transfer heat from the heavy water reactor coolant on the steam generator primary side to the light water on the secondary side. Details of the secondary side are described in Chapter 5.

The primary side of the steam generators consists of the head, the primary side of the tubesheet and the tube bundle. A partition plate separates the inlet section of the head from the outlet section. The U-tubes are welded to the primary side of the clad carbon steel tubesheet. The head is provided with two access manways, one for the inlet side and one for the outlet side.

The rate of incidence of heavy water leakage from a steam generator is minimized by very high standards in design and manufacture. High recirculation ratios, low heat fluxes, elimination of tube vibration, material selection and both primary side and secondary side chemistry control contribute to long steam generator tube life. When maintenance of the primary side of the steam generator is required, the coolant level in the heat transport system be lowered below the bottom of the steam generators, with coolant circulation and decay heat removal provided by the shutdown cooling system.

The four heat transport pumps are vertical, single-stage, single-suction, single-discharge centrifugal pumps. A heat transport pump is shown in Figure 4.2. The pump casing is of a double-volute design and consists of a vertical bottom suction nozzle, the main bowl, and one horizontal discharge nozzle. The pump cover is mounted on top of the casing and sealed by a double gasket. The cover consists of a bottom flange which mates with the casing and a vertical section housing. The cover consists of a bottom flange which mates with the casing and a vertical section housing the shaft seals.

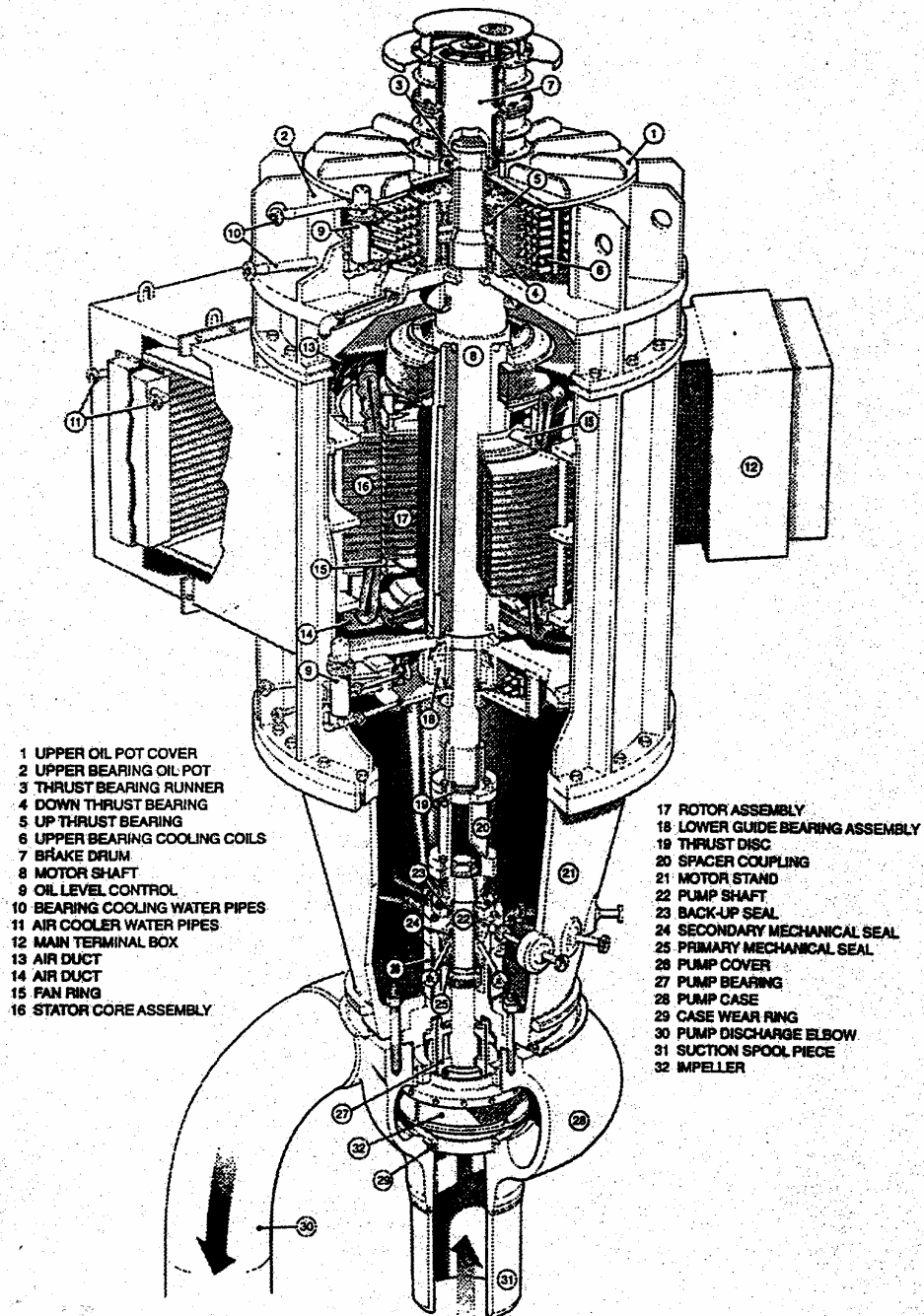

Figure 4.2. Heat Transport Pump.

The pump bearing is located above the impeller. The shaft seals are located above the bearing. The shaft sealing arrangement consists of three mechanical seals and one backup seal in series. Each mechanical seal is designed to withstand the full system pressure. All three rotary seal components are attached to the seal sleeve, which in turn is attached to the shaft. The stationary components are attached to the seal housing which is bolted to a seal flange. In turn, the seal flange is bolted to the pump cover. The backup seal is located at the top of the seal assembly. In the unlikely event that all three mechanical seals fail, the backup seal prevents significant leakage of heavy water to containment while the heat transport system is being depressurized.

When maintenance of the shaft seals or the pump internals is required, the coolant level in the heat transport system is lowered to below the heat transport pumps, while fuel cooling is maintained by the shutdown cooling system.

The pump seal cooling system supplies cooled, filtered, and purified heavy water for lubricating and cooling the mechanical seals. The heavy water is injected below the lowest mechanical seal, at a pressure above pump suction pressure. A small portion of the seal coolant flows upwards through the mechanical seals and the remainder flows downwards into the pump casing. If external gland seal cooling system flow becomes unavailable, heavy water is supplied to the mechanical seals directly from the pump casing.

A leakage recovery cavity, located between the uppermost mechanical seal and the backup seal, routes the normal seal leakage and leakage from a failure of all three mechanical seals, to the leakage collection system.

Each pump is driven by a vertical, totally enclosed, air/water-cooled squirrel cage induction motor. The motor is supported by the motor mount which is bolted to the top of the pump case. A removable coupling connects the motor shaft to the pump shaft. Removal of the coupling allows sufficient space for the pump seals and bearings to be removed without removing the motor.

The pump/motor unit has sufficient rotational inertia, supplemented by inertia packets in the motor so that, on loss of power, the rate of coolant flow reduction matches the power rundown following the reactor trip. Natural circulation maintains adequate cooling of the fuel after the pumps stop.

The motor is equipped with two removable radial bearings and a double-acting thrust bearing. The motor bearings are lubricated by cooled and re-circulated oil. An oil lift system, referred to as the jacking oil system, supplies high pressure oil to both sides of the thrust bearing simultaneously, during startup.

Shielding is installed between the pump casing and the pump motor to reduce the irradiation of personnel engaged in pump and motor maintenance and other maintenance tasks above the pump casing.

The power supply for each heat transport pump is normally from the unit service transformer. The motor is able to withstand the supply interruption caused by automatic transfer between the unit service transformer and the station service transformer.

Instrumentation and Control

The heat transport system requires no automatic feedback control devices for proper operation. Flows, pressure differentials and temperature distributions are determined by pump characteristics, line sizes, steam generator characteristics and reactor power level. The instruments connected to the heat transport system are for the control of related systems and the reactor, and are described in detail in other sections.

Instrumentation is provided to monitor and/or control the following:

- Heat Transport Pumps.
 - The pumps are fitted with transducers to measure speed and jacking oil pressure, and to detect vibration. Alarms are annunciated in the control room on high vibration, and on low jacking oil pressure during pump startup.
 - The motor is fully instrumented, and data on oil level on upper and lower oil sumps, bearing temperatures, winding temperatures and current are fed to the distributed control system.
 - The pump motor is tripped on high thrust bearing temperature which could result from a loss of service water.
 - Reactor Outlet Header Pressure Measurements for Heat Transport System Pressure Control.
 - Reactor outlet headers carry two sets of pressure measurements.
 - Triplicated measurements are used for narrow-range pressure control of the system during normal operation. A single measurement in each outlet header is used for wide-range pressure control of the system, during warm-up of the heat transport system.
 - Reactor Outlet Header Pressure Measurements for the Emergency Core Cooling System.
 - After a loss-of-coolant accident and reactor trip, fuel is cooled by injecting water from the emergency core cooling system into the reactor headers. For operation of this system, pressure measurements are taken off each reactor outlet header.
 - Reactor Outlet Header Pressure Measurements for Heat Transport System Overpressure Protection, and for shutdown system number 1 and shutdown system number 2.
 - Each reactor outlet header carries triplicated pressure measurement loops for each of the safety shutdown systems. These signals are also used to open the two liquid relief valves on high system pressure.
 - Header Level Measurements.
 - During repair or inspection of a heat transport pump or steam generator the heat transport system coolant is drained to a level just above the headers and fuel cooling is maintained via the shutdown cooling system. Coolant level is maintained within a range that provides adequate coolant level above the reactor inlet feeder inlets, and avoids starving the shutdown cooling pumps.
 - Gross Low Flow Trip System.
 - Gross low flow is detected by triplicated flow measurements. Shutdown systems number 1 and number 2 trip the reactor when certain combinations of feeder flow measuring elements detect low flow.
-

4.2 HEAT TRANSPORT PRESSURE AND INVENTORY CONTROL SYSTEM

The heat transport pressure, and inventory control system performs the following functions:

- Controls the pressure and heavy water inventory in the heat transport system for all normal operating conditions.
 - Limits pressure increases and decreases in the heat transport system due to various operating transients to acceptable values.
 - Accommodates heat transport system coolant swell and shrinkage associated with warm-up, cool-down, power maneuvering and other unit disturbances.
 - Provides for suitable heat transport system pressure recovery following sudden pressure reduction due to power reduction, such as a trip or a stepback.
 - Limits pressure reduction in the heat transport system due to sudden depressurization of the secondary side of the steam generators.
 - Provides overpressure protection for the heat transport system for all modes of operation and a means of containing any relief from the heat transport system in the short term.
- Provides adequate net positive suction head for the heat transport heavy water feedpumps during normal reactor operation.
- Provides the heat transport pump glands and the fuelling machines with a cool and purified heavy water supply flow.
- Minimizes outflow of heat transport coolant due to the failure of associated valves.
- Provide the heat transport purification system with a cool heavy water flow.
- Transfers heavy water from the heat transport system to the heavy water supply storage tanks via the heavy water storage tank when maintenance of heat transport system equipment, requiring partial draining of the heat transport system, is undertaken.
- Provides light water make-up to compensate for a small loss-of-coolant accident, if normal D₂O makeup is depleted or unavailable.
- Provides a means of degassing the heat transport system coolant.
- Provides a process parameter (pressurizer level) for safety system action (shutdown systems number 1 and number 2).

A simplified flowsheet of the system is shown in Figure 4.3. The pressurizer is connected to the main heat transport system at one of the steam generator inlet lines by the pressurizer connection line. A valve is provided to isolate the pressurizer from the heat transport system during maintenance shutdowns.

The heavy water in the pressurizer is heated by electric heaters if the liquid's temperature falls below the desired saturation temperature. During heat transport system warm-up, the heaters are used to increase the pressure in the pressurizer.

The cushioning effect of the heavy water steam volume in the pressurizer is supplemented by pressurizer spray when the pressure rises above a setpoint. The spray flow is supplied from the discharge of the heavy water feedpumps. Two steam relief valves are provided for overpressure protection of the pressurizer when it is isolated from the heat transport system.

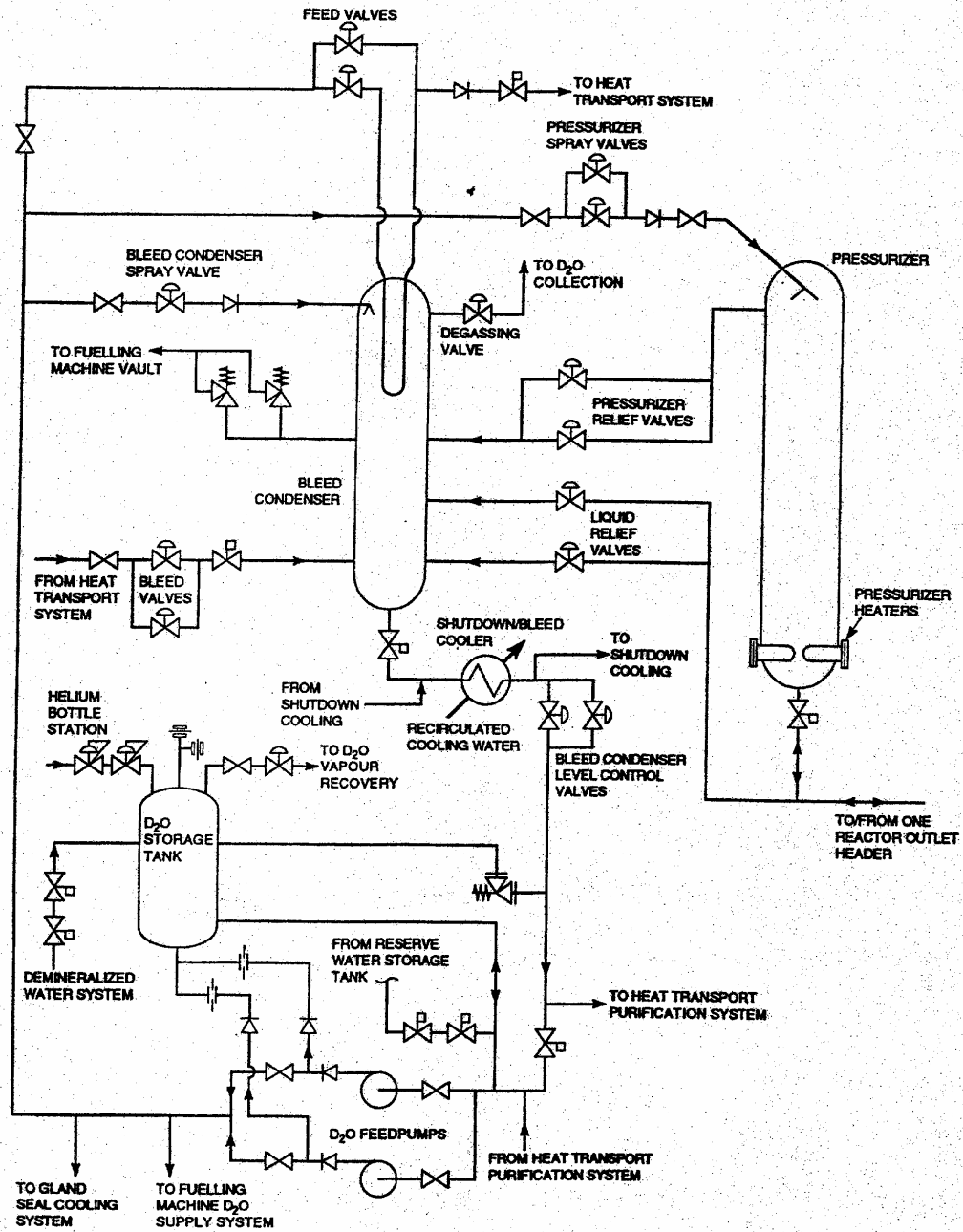

Figure 4.3. Heat Transport Pressure and Inventory Control System.

The pressurizer stores the heavy water displaced by the change in volume of the reactor coolant in the heat transport system during warm-up and startup from 100°C to full power. The pressurizer level setpoint increases with heat transport system temperature during warm-up and with reactor power during startup to accommodate the volume change between zero power cold and full power. The heavy water level is automatically controlled at the setpoint by the heavy water pressure and inventory control system under the control of computers.

Vapourization of part of the saturated liquid heavy water stored in the pressurizer minimizes the pressure decrease caused by the outflow of heavy water following a reduction in reactor power. The pressure is restored to the setpoint by the electric heaters.

When the reactor is at low power and the heat transport pumps are shut off, the pressurizer may be isolated from the heat transport system. In this case, the pressure control of the heat transport system is achieved by feed and bleed. This is called 'solid mode' operation.

Feed and Bleed Circuit

Inventory control (or pressure control during the solid mode) for the heat transport system is achieved by feed and bleed.

Bleed flow is taken from the suction of one of the heat transport pumps and discharged into the bleed condenser via the bleed valves as two phase flow. The steam is condensed in the bleed condenser by a reflux cooling tube bundle with cooling flow from the feed flow. The tube bundle recovers part of the heat from the bleed flow. The bleed flow is then further cooled by the shutdown/bleed cooler before entering the heat transport purification system via the bleed condenser level control valves. The shutdown/bleed cooler is isolated from the shutdown cooling system during reactor operation by two motorized valves (refer to Section 2.6 for more details on the shutdown/bleed coolers). The bleed condenser level control valves maintain the heavy water level in the bleed condenser at the setpoint.

One heavy water feedpump is normally operating and takes water from the heavy water storage tank and/or the heat transport purification system. It supplies the required flow through feed control valves to the heat transport system via the heat transport pump suction line.

The signal to feed or bleed heavy water to or from the heat transport system is based on the pressurizer level during power operation, and on reactor outlet header pressure during 'solid mode' operation with the pressurizer isolated.

The heavy water feedpump also provides:

- a cool spray flow to the pressurizer for pressure control,
 - a cool spray flow to the bleed condenser for pressure control,
 - cool heavy water to the fuelling machine heavy water supply system, and
 - a cool flow through the bleed condenser reflux tube bundle for heat recovery.
-

Storage and Transfer Circuit

The heavy water storage tank, which is connected to the suction side of the heavy water feedpumps, serves as the head tank for the pumps. During initial warm-up to 100°C, the heavy water swell from the heat transport system is accommodated in the heavy water storage tank. This volume of heavy water provides more than 30 minutes of feed flow, for heat transport pump gland cooling in the event of loss of bleed flow. Heat transport pump seal cooling return flow and feedpump recirculation flow circulates through the heavy water storage tank before returning to the heavy water feedpump suction. Helium is used as cover gas for the heavy water storage tank.

The heavy water storage tank is connected to the heavy water transfer system by a line with a normally closed valve. This line is used to transfer heavy water to and from the heavy water storage tank. Transfer is required typically during a maintenance shutdown, when it is necessary to partially drain the heat transport system to service the steam generators and/or the heat transport pumps.

Following a small leak in the heat transport system, operator action can be initiated to supply make-up to the heat transport system. Make-up water is drawn from the reserve D₂O inventory at the station (including downgraded D₂O) and transferred to the D₂O storage tank. If the leak cannot be stopped before the D₂O reserve is exhausted, light water make-up from the reserve water tank can be valved in to provide light water make-up to the suction side of the heavy water feed pumps.

Instrumentation and Control

The pressure and inventory control system includes flow, level, pressure and temperature measurement and control loops which provide pressure and inventory control for the heat transport system. The most important parameters to be controlled are described in the following sections.

Normal (or Narrow-Range) Heat Transport System Pressure Control.

The heat transport system pressure is controlled by condensing steam or by heat addition to the pressurizer, utilizing the pressurizer spray or the heaters at the bottom of the pressurizer respectively, under normal power-producing operation.

Triplicated sets of pressure measurements taken from the reactor outlet headers are used for heat transport system pressure control. The control system selects the reactor outlet header that has the highest pressure and controls this pressure to the desired value. This is done by feeding all the outputs of the pressure transmitters into the distributed control system. The median pressure on each header is determined, and the higher of the median pressures is compared with the system setpoint. If the pressure is above the setpoint, the spray valves on the pressurizer open to reduce pressure and, if below the setpoint a heater in the pressurizer is turned on to increase pressure. This pressure control system operates on a narrow-range transmitter signal for greater accuracy.

The variable heater is used under normal steady state conditions. The on-off heaters come on when the pressure drops below the proportional control band setting of the pressure

controller. The on-off heaters also come on if the water temperature falls a predetermined amount below the normal saturation value.

Wide-Range Pressure Control.

During 'solid mode' feed and bleed pressure control operation, the pressurizer is isolated from the heat transport system. In this case the wide-range pressure control system is used. This is a single-channel system and uses signals from pressure transmitters located on the reactor outlet headers. The higher of the reactor outlet header pressures is selected and is compared to the setpoint. The output from the distributed control system is fed to the two feed valves and the two liquid bleed valves which control heat transport system pressure. The wide-range pressure control is not used above 5% reactor power.

When isolated, the pressurizer pressure is controlled by a single-channel pressure control loop which controls the spray valves and the heaters. Overpressure protection is provided by two pressure relief valves on the pressurizer.

Pressurizer Level (Inventory Control) and Temperature Control.

The level in the pressurizer when connected to the heat transport system is controlled via the feed and bleed valves. Triplicated level measurements are fed to the distributed control system where the median is calculated. The level setpoint is programmed as a function of heat transport system reactor inlet header temperature, reactor outlet header pressure and reactor power.

During increases in reactor power, the pressurizer accommodates the resultant heat transport system swell. The water flowing into the pressurizer is below the saturation temperature. This condition is sensed by temperature detectors in the pressurizer and the heaters are turned on to increase the water temperature to the saturation value. The rising water level compresses the vapour space above the water and pressure is maintained at the setpoint by the spray valves. The pressurizer heaters are shut off automatically on low pressurizer water level.

Bleed Condenser Level and Pressure Control.

Level in the bleed condenser is controlled via the distributed control system. Two 50 percent capacity level control valves regulate the outflow from the bleed condenser to maintain a constant level in the bleed condenser.

Pressure in the bleed condenser is controlled via the distributed control system. Pressure is regulated by condensing the vapour in the bleed condenser with cooling flow through the reflux tube bundle and a spray flow supplied from the heavy water feedpumps. The reflux bundle flow and the spray flow are regulated by control valves as demanded by the pressure controllers.

Shutdown/Bleed Cooler Temperature Control

Control of the cooler outlet temperature is performed via the distributed control system. The downstream heavy water temperature must be sufficiently low to ensure feedpump net positive suction head and to avoid damage to the ion exchange resin and to the glands of the heat transport pumps. Over-temperature protection is provided by override controls, which close the bleed condenser level control valves on high temperature at the cooler outlet.

4.3 SHUTDOWN COOLING SYSTEM

The major functions of the shutdown cooling system are to:

- a. Cool the heat transport system after a reactor shutdown and following an initial cool-down by steam rejection, to a temperature suitable for maintenance.
- b. Maintain the heat transport system temperature at the maintenance level for any desired length of time.
- c. Provide a means of draining, refilling and level control of the heat transport system to allow maintenance of the heat transport pumps or steam generators.
- d. Cool down the heat transport system from the zero power hot temperature under abnormal conditions.
- e. Provide a long term heat sink after a design basis earthquake, following depletion of Group 2 feedwater to the steam generators.

A simplified flowsheet of the shutdown cooling system is shown in Figure 4.1.

The system consists of two circuits, one located at each end of the reactor. Each circuit consists of one pump, one heat exchanger, valves and piping. Since the heat transport system layout at each end of the reactor features two inlet headers and one outlet header in a single loop arrangement, the symmetry provides good flow distribution during normal shutdown operation.

In each circuit, the pump takes suction from reactor outlet header and discharges via the heat exchanger into the two inlet headers at the same end of the reactor. The design pressure and temperature for the shutdown cooling system are compatible with the heat transport system. The system is normally full of heavy water and isolated from the heat transport system by the header isolation valves.

One of the coolers, called the shutdown/bleed cooler, carries out the dual functions of shutdown cooling and bleed cooling. A small isolation valve, called the warm-up valve, is located in parallel with one of the inlet header isolation valves. This valve is used for warming the shutdown cooling system. Cooling water to both heat exchangers (shutdown/bleed cooler and shutdown cooler) is provided by the re-circulated cooling water system. The shutdown cooler is provided with seismically qualified Group 2 raw service water backup cooling supply, which can be initiated if the normal re-circulated cooling water supply fails. This improves the shutdown cooling system reliability as a heat sink, following a DBE and when the steam generators are drained during maintenance.

There are two bypass lines; one bypassing the pump/heat exchanger and another bypassing the pumps only. Both lines have a motorized valve for isolation. The pump/heat exchanger bypass line is used to moderate the cooling efficiency of the heat exchangers. The pump bypass allows the shutdown coolers to be used with the heat transport pumps when the shutdown cooling pumps are unavailable.

For normal heat transport system cool-down, steam from the steam generators bypasses the turbine and flows into the turbine condenser to reduce the heat transport system temperature from the hot shutdown temperature to 177°C in approximately 30 minutes.

Cool-down from 177°C to 54°C or below is achieved using the shutdown cooling system. Initially all motorized valves in the system are closed. The bleed condenser is isolated before switching from steam generator to shutdown cooling for cool-down. The outlet header isolation valves are opened to pressurize the system and ensure adequate NPSH. The heat transport pumps are shut down and the shutdown cooling pumps are started. The isolation valves to both heat exchangers and the pump/heat exchanger bypass valve are opened. The warm-up valves are opened to allow warm-up of the shutdown cooling piping. The inlet header isolation valves are then gradually opened. Both coolers are valved in for cool-down and the pump/heat exchanger bypass valve is maintained in a partially open position to prevent the cool-down rate from exceeding the design rate of 2.8°C per minute.

When the shutdown cooling system is in the long-term cool-down mode with both shutdown cooling pumps operating and with the heat transport system full, part of the shutdown cooling flow bypasses the core through the steam generators and pumps. In the event of failure of one of the shutdown cooling pumps, the reactor outlet header temperature increases slightly but does not result in boiling in any of the fuel channels.

For steam generator or pump maintenance, or inspection requiring the opening of the pressure boundary, the heat transport system coolant is drained to near the header level. The heavy water removed from the heat transport system is sent to the heavy water storage tank. Under this operating condition, all the shutdown cooling system flow goes through the core. Manual feed and bleed is used to control the heavy water level in the heat transport system. If one pump fails under this condition, header water level changes are within an acceptable range. The heavy water feedpumps are used to refill the heat transport system.

With re-circulated cooling water available, the shutdown cooling system can be used to cool the heat transport system from 260°C for a limited number of cycles. The cool-down procedure is similar to that of normal cool-down using the shutdown cooling pumps, with the exception that only one heat exchanger is valved in initially. The second heat exchanger is valved in at a lower temperature.

Under abnormal conditions, such as loss of both shutdown cooling pumps, the shutdown cooling system can operate under the heat transport pump mode. In this mode, the shutdown cooling system pumps are off, the pump bypass valve is opened and coolant flow is driven through the shutdown coolers by the heat transport pump, from the inlet header to the outlet header.

The shutdown cooling system can be valved in as a long term heat sink after a design basis earthquake. The shutdown cooler is provided with seismically qualified Group 2 raw service water as a backup to the normal re-circulated cooling water supply. The re-circulated cooling water isolation valves to the heat exchanger are closed before raw service water is valved in.

4.4 HEAT TRANSPORT AUXILIARY SYSTEMS

Heat Transport Purification System

The heat transport purification system performs the following functions:

- Minimizes buildup of radioactive corrosion products in the heat transport circuit.
- Minimizes the concentration of fission products released from fuel defects into the heat transport coolant.
- Assists in maintaining proper pH (pD) control of heat transport coolant.
- Provides for purification during normal reactor operation and during initial stage of shutdown and cool-down (whenever the heat transport pumps are operating).
- Provides a source of clean heavy water for heat transport system makeup.
- Suppresses oxygen generated from radiolysis of heavy water by the addition of hydrogen.

The purification system is a low pressure and low temperature system. The bleed valves are conditioned by a biased signal which provides the required purification flow into the bleed condenser. The pressure in the bleed condenser provides the head to circulate the flow through the purification circuit. The purification flow passes through cartridge filters and ion exchange columns before routing to the heavy water feed pump suction. A bypass line connects the heavy water feed pump suction to the outlet side of the shutdown/bleed cooler to provide a bleed path when the purification system is isolated. To evaluate the performance of the system, coolant samples are taken at the outlets of the cooler, filter and each ion exchange column.

The maximum purification flow rate is based on a purification half-life of approximately one hour. During normal operation, purification flow is reduced to provide a purification half life of four hours. (The purification half-life is the time taken to reduce the concentration of dissolved solids by 50 percent, assuming no addition of solids.)

The purification system functions during normal reactor operation to limit activity and corrosion product buildup in the coolant by removing soluble and insoluble impurities and by maintaining the pH_A (apparent pH) of the heavy water at the required value. It also removes soluble and insoluble impurities following a sudden increase caused by a chemical, hydraulic or temperature transient. In this manner, the activity buildup caused by activated corrosion products is minimized. Hydrogen is added via the purification system to suppress oxygen generated by the radiolysis of heavy water.

Corrosion products deposit on piping surfaces throughout the heat transport system. These products move around the system in both ionic and particulate forms, being released from surfaces, transported some distance and then deposited elsewhere. The recommended coolant alkalinity inhibits the deposition of corrosion products on the fuel surfaces, thus minimizing activation. This minimizes the contribution made by activated corrosion products to

radiation fields and, hence, to the radiation dose to operating personnel. The purification system assists in maintaining proper pH_A of the coolant through the use of mixed-bed resin with the cation resin portion being in the lithium form (Li^+). The ion exchange resin releases lithium ions which slowly raises the heat transport pH_A as cation impurities are removed. Alternatively, use of deuterium-form cation resin reduces the lithium concentration and also the pH_A .

The purification system assists by removing corrosion products both before and after their activation and by removing fission products, notably iodine and cesium which may be released from fuel defects.

Heat Transport Heavy Water Collection System

The heat transport heavy water collection system performs the following functions:

- Collects heavy water leakage from double-packed valve stems, pump seals and inter-gasket cavities during reactor operation.
 - Collects heavy water drainage from equipment before performing maintenance.
 - Provides a means of venting equipment containing heavy water.
 - Provides for sampling to determine the D_2O isotopic and chemical impurity concentrations.
 - Cools and transfers the collected heavy water, if of reactor grade isotopic, to the heat transport pressure and inventory control system.
 - Transfers the collected heavy water, if not of reactor grade isotopic, to the heavy water cleanup system.
 - Provides for monitoring of the heavy water leakage and drainage flows.
 - Provides alarm upon detection of water in the heat transport pump motor stand drains line and on the heavy water collection tank support floor.
 - Provides a means for condensing degassing flow from the heat transport system and to vent off non-condensable gases to the reactor building ventilation system.
 - Provides tank level indication and alarm to avoid D_2O going up the vent line during a period of abnormally high leakage collection.
-

4.5 HEAT TRANSPORT SYSTEM OPERATION

System Warm-up

Following a prolonged shutdown, the heat transport system could be at atmospheric pressure and at ambient temperature. The heat transport system coolant may be drained to near the header level or it may be completely filled. The heat transport pumps are stopped and cooling is provided by the shutdown cooling system. The pressurizer is partially filled with heavy water and is isolated from the heat transport system.

In preparation for system warm-up, the heat transport system must be refilled if it has been partially drained and then put on 'solid mode' pressure control. The main circuit can be pressurized by the heavy water feedpumps.

The initial stage of warm-up involves activating the pressurizer heaters which results in a gradual increase in pressurizer temperature and pressure. The pressurizer isolation valve is opened and heat transport pressure control is transferred to the normal mode prior to startup of the heat transport circulating pumps.

The next step of warm-up involves stopping both shutdown cooling pumps and closing the shutdown cooling/reactor outlet header isolation valves. The heat transport pumps are started. The system is warmed up by pump heat and low reactor heat. The shutdown cooling/reactor inlet header isolation valves are closed when the heat transport temperature reaches 177°C and normal bleed is established via the bleed condenser and bleed valves. System swell up to 100°C is stored in the heavy water storage tank. The swell during the remaining warm-up period is accommodated in the pressurizer. The heat transport system is pressurized in steps as the system temperature increases.

Startup

After warm-up, the heat transport system coolant temperature and pressure at the outlet header are the zero power hot values. The pressurizer is hot and pressurized and is connected to the main heat transport circuit. Raising of reactor power can now begin.

The design maneuvering rates are:

Power Range	Maximum Rate
0 - 25 percent of full power	4 percent of actual power per second
25 - 80 percent of full power	1 percent of full power per second
80 - 100 percent of full power	0.15 percent of full power per second

As reactor power increases, the reactor outlet header pressure rises as a result of the swell in the system. Thus heavy water is forced into the pressurizer compressing the vapour phase. The control system corrects the mismatch between the actual and the desired pressure of the pressurizer by condensing steam in the pressurizer utilizing the heavy water spray. As the reactor power is increased, the level setpoint in the pressurizer increases automatically so that all the swell resulting from power increases is stored in the pressurizer.

Full Power Operation

During normal operation the pressure and inventory control system controls the heat transport system inventory by maintaining the pressurizer level at the required value. The heat transport system pressure is controlled by maintaining the heavy water vapour space in the pressurizer at the desired pressure.

Shutdown

The sequence of operation performed during heat transport system shutdown generally follows the startup sequence in reverse, except for one major difference. Whereas startup from zero power hot to full power can be achieved at constant or rising heat transport system pressure, shutdown is accompanied by falling pressure. The reason is that as reactor power is reduced, system shrinkage causes an outflow and, hence, a falling level in the pressurizer. The pressure decrease due to heavy water steam expansion in the pressurizer is acceptable. The net positive suction head available for the heat transport pumps is adequate at all times.

Cool-down

Cool-down of the main circuit from zero power hot to 177°C is achieved by discharging steam from the steam generator secondary side through the condenser steam discharge valves to the condenser or, in case of loss of condenser vacuum, to the atmosphere via the atmospheric steam discharge valves.

Below 177°C the shutdown cooling heat exchanger becomes the heat sink and circulation is provided by the shutdown cooling pumps. Heat transport pumps can be used for circulation if the shutdown cooling pumps are not available. The bleed condenser is isolated and the bleed condenser level control valves take over the function of the bleed valves.

Under abnormal conditions, the shutdown cooling system can achieve cool-down from zero power hot conditions.

The system is depressurized in steps as the system temperature decreases. The system is under 'normal' mode pressure control until the heat transport pumps are shut down, to minimize the chance of pump cavitation due to a sudden depressurization. Once the heat transport pumps are shut down, the operator has the option to continue cool-down in 'normal' mode or switch to 'solid' mode control.

When the heat transport system temperature falls to 54°C, the heat transport system may be depressurized and the coolant level lowered to near the header level. The coolant is removed via the shutdown cooling system and transferred to the heavy water storage tank. To assist in removing coolant from the heat transport system, nitrogen is added through the heat transport pump seal cavity.

If a short shutdown is expected it is desirable to isolate the pressurizer and maintain it pressurized, since heating the pressurizer takes much longer than heating the heat transport system. If an extended shutdown is planned, the pressurizer will usually be isolated from the

heat transport system and depressurized with the pressurizer heaters switched off. Heat transport system pressure control is under 'solid' mode.

Degassing

After the heat transport system is refilled following maintenance, it will have a high concentration of nitrogen. The concentration of nitrogen can be reduced by opening the degassing valve which discharges to the heavy water collection tank. The steam is condensed by a spray flow in the heavy water collection tank and the gas effluent is discharged to the reactor building ventilation system via the vapour recovery system.

Copyright information for Chapter 4:

Figures on pages 4-3, 4-5 and 4-9 are from CANDU[®] 9 480/NU Technical Description, AECL document 69-01371-TED-001 Rev. 1, January 1995. Reprinted with permission of Atomic Energy of Canada Limited (AECL).

CHAPTER 5

STEAM, TURBINE AND FEEDWATER

CHAPTER OBJECTIVES:

At the end of this chapter, you will be able to describe the following features of the steam, turbine and feedwater systems used in CANDU generating stations:

1. How steam is produced, transferred to the turbine, condensed, and returned to the boilers;
2. The reasons for the main design and operating features of the Turbine;
3. The process of optimizing the thermodynamics of the steam and feedwater cycle;
4. The use of three element control to minimize fluctuations of steam generator level;
5. The use of standby equipment to ensure that the boilers are maintain their role as heat sinks;
6. The steam flows during 'Poison Prevent' Operation, regulation of steam generator pressure and protection against overpressure.

The steam and feedwater system performs the following functions:

- a) Provides the means for the transfer of heat energy from the primary heat transport system, and for the production of steam.
 - b) Conveys the steam produced in the steam generators to the high pressure turbine and other balance of plant loads.
 - c) Provides for overpressure protection of the steam generator secondary side.
 - d) Provides instrumentation for steam generator level and pressure control.
 - e) Provides for a crash cool of the steam generators on a loss-of-coolant.
 - f) Enables testing of one turbine stop valve at a time without interruption to the unit and without causing problems in control of steam generator water levels.
 - g) Provides feedwater to each steam generator and maintains steam generator secondary side water levels.
 - h) Provides for cool-down of the heat transport system following a design basis earthquake.
 - i) Provides for a remote manual isolation of each pair of steam generators from the steam system (as may be required in the event of a tube leak).
-

The simplified flowsheet of the 'secondary' side of a nuclear generating station that includes the steam, turbine-generator and feedwater systems is shown in Figure 5.1. The values of pressure, temperature, etc., quoted in the text refer to full power operation and are approximate. Real values differ slightly from station to station. The systems we will consider in some detail are the Steam Generator, Main Steam, Turbine, Condenser, Feedheating and Feedwater, including the major process, control and protective systems.

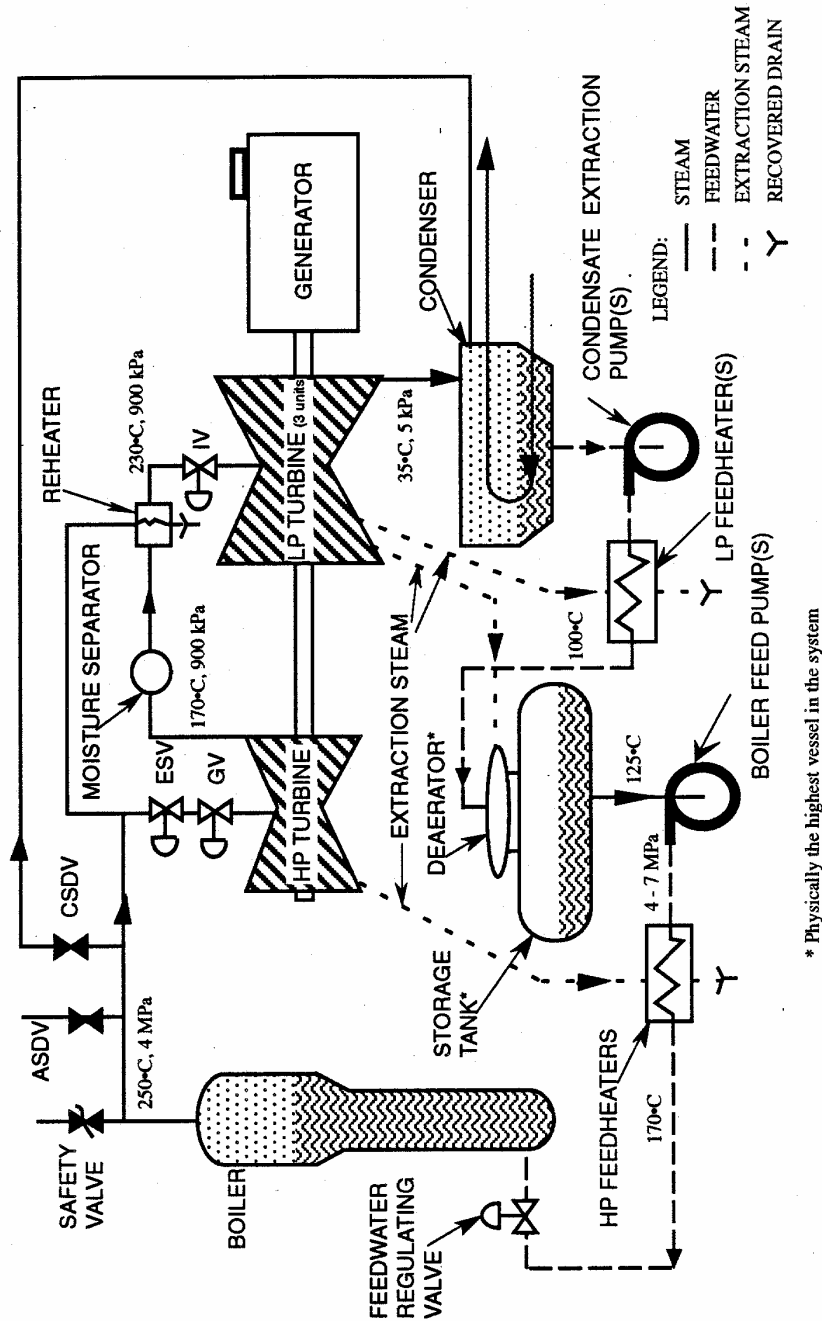

Figure 5.1. Simplified Diagram of Balance of Plant Systems, including Steam Generator, Main Steam, Turbine, Generator, Condenser and Feedwater Systems.

5.1 STEAM GENERATOR (BOILER)

During normal operation, the heat transport system transfers heat from the reactor to the secondary coolant by way of the boilers. The boilers thus act as the principal heat sink for the reactor. Reactor heat is transferred from the heat transport system to the boiler feedwater. As a result, the boiler produces steam to drive the turbine.

Figure 5.2 shows a boiler typical of those used in large nuclear generating stations. Hot, pressurized heavy water enters the boiler and passes through the tube bundle. The heavy water inside the tube is hotter than the feedwater around the tubes. This allows heat transfer from the heavy water to the feedwater, causing the feedwater to boil.

The steam leaving the top of the tube bundle is about 90% water. To prevent damage to the steam piping, valves and (most important) the turbine, only dry steam must leave the boiler. Cyclone separators, located above the tube bundle, dry the steam by giving the steam/water mixture a swirling centrifugal motion. The water, being denser than steam, moves to the outside area of the separator and is drained off. The steam that leaves the top of the cyclone separators has low moisture content but is still unacceptable for use in the turbine. The steam scrubbers, located above the cyclone separators, remove the last traces of moisture.

Water separated from the steam in the cyclone separator and steam scrubber drains to the outside of the boiler's tube shroud. The water flows down to the bottom of the boiler through the downcomer annulus and re-enters the tube bundle area enabling it to generate more steam. The amount of water cycling through the tube bundle, through the downcomer, is typically ten times as much as feedwater entering the boiler.

The water in the boiler moves through natural circulation without the use of pumps. The water and steam in the tube bundle move upward because of the decrease in density due to the addition of heat. The water that comes out from the cyclone separators is relatively dense, because it has no steam bubbles, and falls down the downcomer to begin the cycle again.

The feedwater flow in the boiler starts from the preheater. The preheater heats the feedwater to near saturation temperature. Inside the boiler the feedwater circulates up around the tube bundle and down the downcomer many times while acquiring the latent heat of vaporization, and finally leaves the boiler as nearly saturated steam.

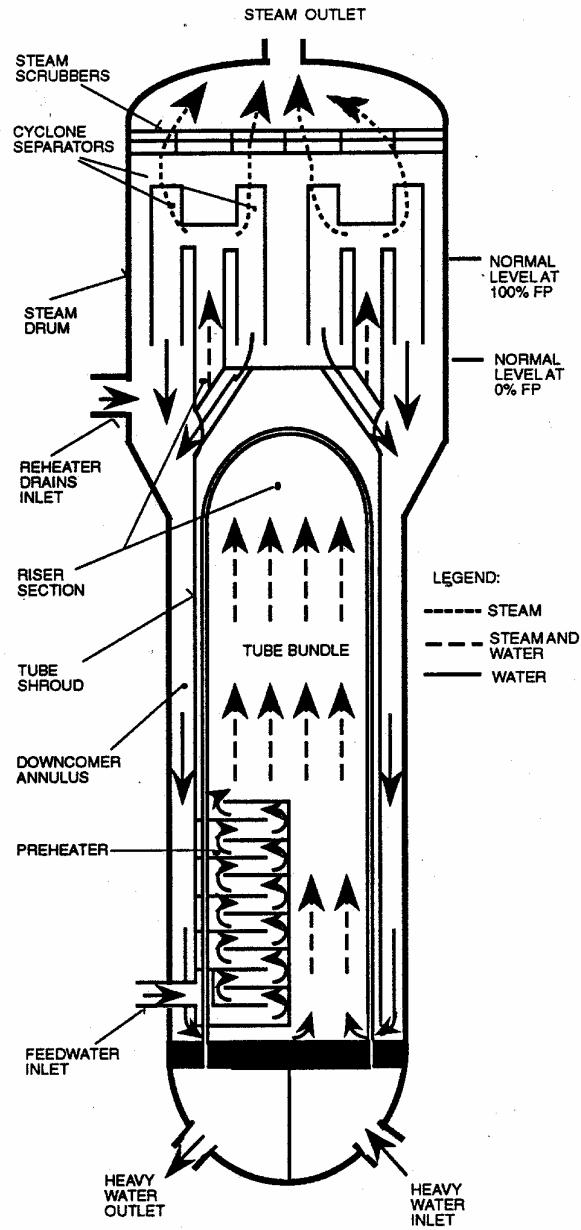

Figure 5.2. Typical Steam Generator or Boiler used in CANDU stations.

5.2 STEAM SYSTEM

Figure 5.3 shows a simplified schematic of the steam system and components typical of a large turbine unit. Safety valves installed on top of the boiler protect the steam system components from over pressure. The pressure from the boilers drives the steam to the high pressure (HP) turbine. On route to the turbine the steam travels through several valves. Two of interest are the emergency stop valves and the governor valves. The governor valve controls the quantity of steam flowing to the turbine, and therefore controls the speed of the turbine when not connected to the grid, and when the generator is synchronized to the grid, it determines the electrical output of the unit. Before reaching the governor valve the steam passes through the emergency stop valve. The emergency stop valve quickly stops the steam flow to the turbine in the event of an emergency that could damage the turbine.

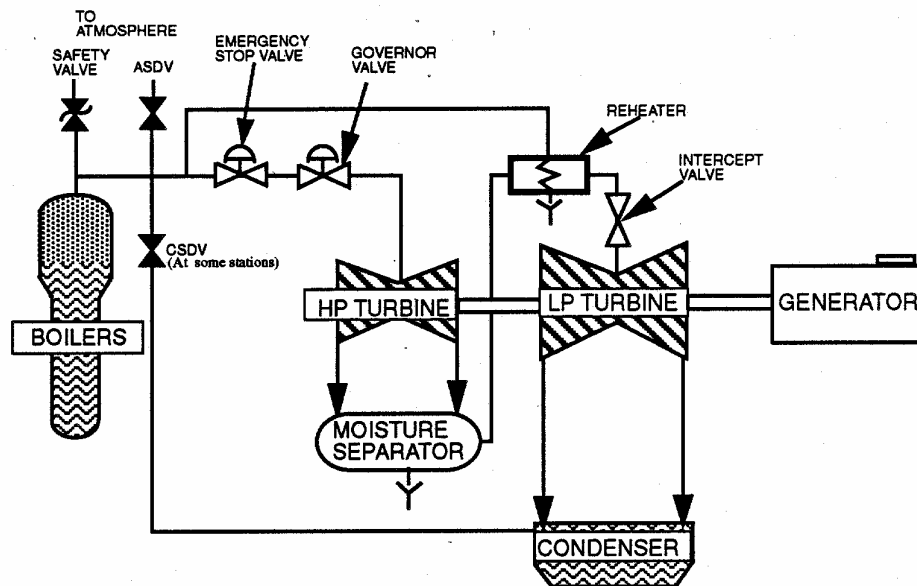

Figure 5.3. Simplified Steam System.

From the governor valve the steam passes through the HP turbine. The HP turbine converts the latent heat of the steam to mechanical energy. As the HP turbine uses the latent heat in the steam, the steam becomes wet (moist). Moisture content of more than 10% will cause excessive erosion on the turbine blades. Removing the moisture in the steam allows further conversion of the remaining available energy. The HP/LP arrangement of the turbine provides an opportunity at this stage to improve the quality of the steam to allow more energy to be converted with risk of damage to the turbine.

Steam leaves the high pressure turbine at approximately 900 kPa and 170°C at 10% moisture. It passes to the moisture separator which removes the moisture in the steam. Steam leaving the moisture separator has the same temperature and pressure as that at the turbine outlet but without moisture. It then passes through a reheater to heat the steam. This increases the work that the steam can do in the Low Pressure (LP) turbine. The reheater uses steam directly from the boiler to heat the steam from the moisture separator. The steam leaves the reheater in a superheated condition at about 230°C and 900 kPa. Before entering the LP

turbine, the steam passes through intercept valves. In a fashion similar to the emergency stop valves, these valves shut off steam to the LP turbine in an emergency. Steam passes through the normally open intercept valves, passes through the low pressure turbine, and is then exhausted to the condenser at approximately 5 kPa(a), 35°C and 10% moisture.

Stopping the flow of steam to the turbine results in increased boiler pressure. This can happen on a turbine trip. Reducing reactor power and getting rid of the steam prevents excessive boiler pressure build up. Adjusting the reactor power level too low can poison out the reactor. However, if the power level is kept above 60% full power, the reactor can keep operating. Providing an alternative heat sink, while operating at this power level, will prevent a boiler pressure increase. The alternate heat sink can be provided by blowing the steam to atmosphere or directly to the condenser. All CANDU units have large steam reject valves able to discharge steam either to the atmosphere or to the condenser with the reactor at 60% FP They are also equipped with smaller steam reject valves that are able to discharge steam to the atmosphere at the decay heat power level, if the condenser is unavailable.

Main Steam

The steam system of a typical CANDU unit is shown on Figure 5.4. All the valves and other major equipment shown on the previous simplified diagrams can be identified, and the ones of particular relevance to the operation of the Main Steam system are discussed in the following sections.

Main steam safety valves are provided on each steam main to protect the steam system and the steam generators from overpressure.

Provision is made to detect heavy water in the steam. Connections from each steam line to the D₂O in light water detection system provide a continuous on-line measurement capability. Each sampling line also has a low pressure low temperature grab sample valve for periodic assessment of steam chemistry and tritium content.

It may be desirable to isolate any one pair of steam generators following a steam generator tube rupture, or a process failure while operating with a steam generator tube leak. This is accomplished by closing the appropriate turbine stop valves on the steam lines from two steam generators (the steam generator with the tube leak and its companion) and the appropriate steam main interconnect valves by remote manual operation from the main control room. Steam supply to balance of plant steam loads are provided by connections between the steam main interconnect valves. Closure of both steam main interconnect valves also isolates these steam loads.

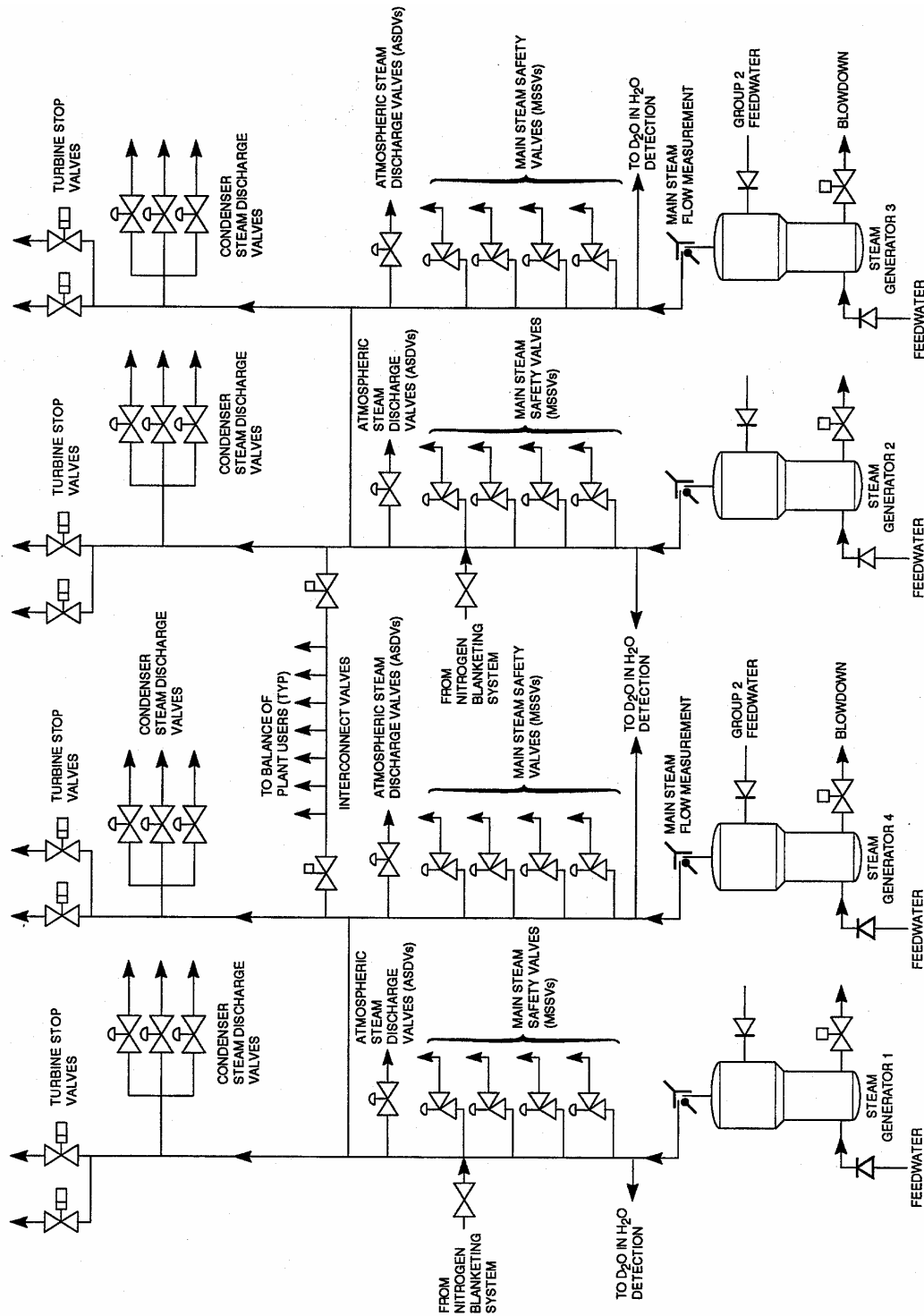

950255-5

Figure 5.4. Typical CANDU Main Steam system.

Steam Generator Blowdown

The steam generator blowdown system is provided to limit impurities in the steam generator. To accomplish this, provision has been made for a continuous blowdown, from the secondary side, at a mass flowrate equal to 0.1 percent of the steaming rate. In the event that the feedwater quality becomes poor, the blowdown rate can be increased to 0.3% of the steaming rate. Blowdown flow is taken from the downcomer area and the tube free lane. Shutoff valves are provided to close off flow from either of these areas. The blowdown rate is controlled by a control valve located in the turbine building. Environmentally and seismically qualified isolation valves are provided in each blowdown line to prevent draining of the steam generators, in the unlikely event of a line break. These valves automatically close on initiation of Group 2 feedwater. The steam generator blowdown discharges into tanks which reduce the temperature and pressure of the blowdown water and provide an effective separation of flashed steam from the water.

Condenser Steam Discharge Valves

The main function of these valves is to discharge live steam to the condenser on loss of turbine so that the reactor can continue to operate at the power required to prevent a 'poison-out'. They are also used to discharge steam on a loss of line, or on a turbine trip, so that the main steam safety valves do not lift. The valves function as follows:

- a. During normal operation they operate on the pressure control mode, with an offset to bias them closed.
- b. During 'poison-prevent', their steady state opening is proportional to the power mismatch between the poison-prevent reactor power level and actual turbine steam consumption.
- c. On a turbine trip, they are first opened fully and then returned to the pressure control mode.
- d. During shutdown to provide a heat sink through the condenser for decay heat removal.

Operation of the condenser steam discharge valves is conditional on the maintenance of adequate condenser vacuum.

Atmospheric Steam Discharge Valves

These low capacity valves are used to control steam generator pressure via the steam pressure control program. They are opened in proportion to the pressure error, normally with an offset in the steam pressure setpoint. These valves may also be used to provide a heat sink during shutdown for decay heat removal when the main condenser is unavailable.

Steam Generator Pressure Control

During normal operation, steam pressure is primarily controlled by adjusting reactor power. If for some reason the reactor regulating system does not allow the reactor to respond to pressure controller demands, or if a reactor power reduction occurs because of a trip, a stepback, or a setback, the reactor setpoint is controlled directly by the respective reduction signal, and the 'normal' mode of control of steam generator secondary side pressure is interrupted. Steam pressure control switches to the 'alternate' mode of adjusting the plant loads.

Turbine Control

When the plant is in the 'normal' mode, the turbine governor valves are controlled through the unit power regulator program; i.e., the unit power regulator calculates what the valve setpoint should be and pulses to that position. If the plant is in the 'alternate' mode, the steam generator pressure control system controls the turbine in response to the steam pressure error, steam pressure error rate of change, and the rate of change of reactor power.

The turbine has a low steam pressure unloader external to the control computers. This overrides directly the turbine governor action including the steam generator pressure control signal, and causes a fast runback of the turbine.

5.3 TURBINE

The turbine converts the pressure of the steam to rotational energy. This conversion involves transformation of the heat energy into high velocity steam through fixed nozzles. The fixed nozzles form the turbine fixed blades. The high velocity steam directs its kinetic energy on to the moving blades forcing them to move (rotate).

From the first set of fixed and moving blades, the steam then moves through succeeding sets to repeat the process of energy conversions. A set of fixed blade nozzles and moving blade constitutes a turbine stage. It is common to use a number of stages in a turbine to convert the useful heat energy in the steam into mechanical energy. The moving blades are attached to a blade wheel and the blade wheel is mounted on the rotor shaft. The high velocity steam leaving the nozzle drives the wheel which in turn rotates the shaft.

The turbine wheels and casing get progressively larger as the steam goes from the high pressure end to the low pressure end. This is necessary to accommodate the expansion of the steam as a direct result of pressure and temperature reduction. Steam entering the high pressure end of a modern nuclear turbine set is typically around 250°C and 4000 kPa. At this temperature and pressure one kilogram of steam occupies 0.05 m³. The steam leaving the turbine unit and entering the condenser is typically around 35°C and 5 kPa(a). At this temperature and pressure one kilogram of steam occupies 25.2 m³. The steam expands roughly five hundred times from the inlet to the exhaust. In a large turbine generator set it is usually not possible to accommodate the large volume of steam in one turbine unit. Normally one high pressure turbine will exhaust to two or more low pressure turbines in combination with the double flow design.

Figure 5.5 shows a turbine unit typical of those installed at CANDU Generating Stations.

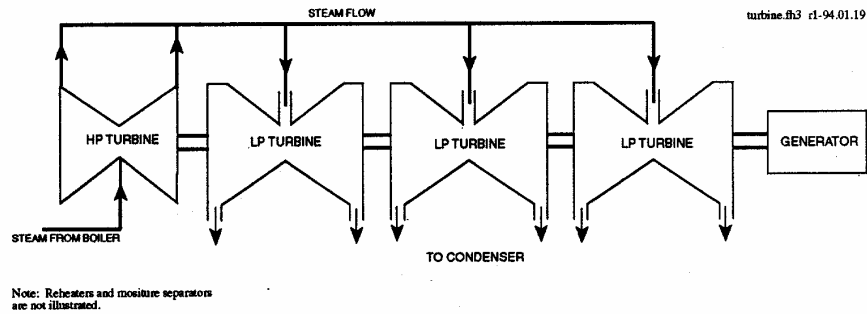

Figure 5.5. Typical Turbine Layout.

The double flow turbine design not only provides double the expansion volume within a common casing, it also balances the large pressure drop between the turbine steam inlet and exhaust which tends to force the blade wheels from the high pressure side towards the low pressure side.

Figure 5.6 shows a double flow turbine. Steam enters the turbine in the middle of the casing and expands outward in both directions before exhausting at the ends of the turbine. Turbine operational problems can still produce an imbalance in forces on the two sides. The resultant force will produce an axial thrust that is commonly dealt with by installing a thrust bearing.

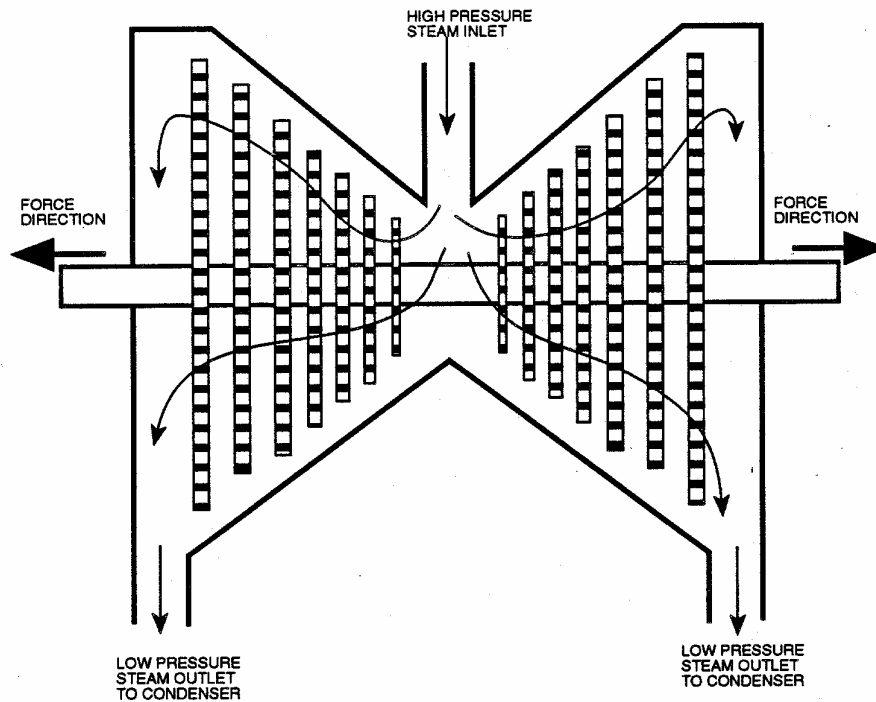

Figure 5.6. Double Flow Turbine

5.4 CONDENSER

The condenser is the final destination for most of the steam produced in the boiler, where it is turned back into water. The large decrease in volume creates a vacuum in the condenser. This permits steam flow from the high pressure boiler to the low pressure condenser so the turbine can extract mechanical energy efficiently.

Figure 5.7 shows a typical condenser used in most CANDU turbine units. The condenser cooling water (CCW) system supplies cooling water to the condenser. The water enters through the inlet water box, passes through the condenser tubes and discharges to the lake through the outlet water box. The turbine exhaust steam enters the condenser through the condenser exhaust trunk and reaches the outside surface of the condenser tubes. The large volume of CCW absorbs the latent heat of vaporization of the steam. The condensate falls into the bottom of the condenser and collects in the hotwell.

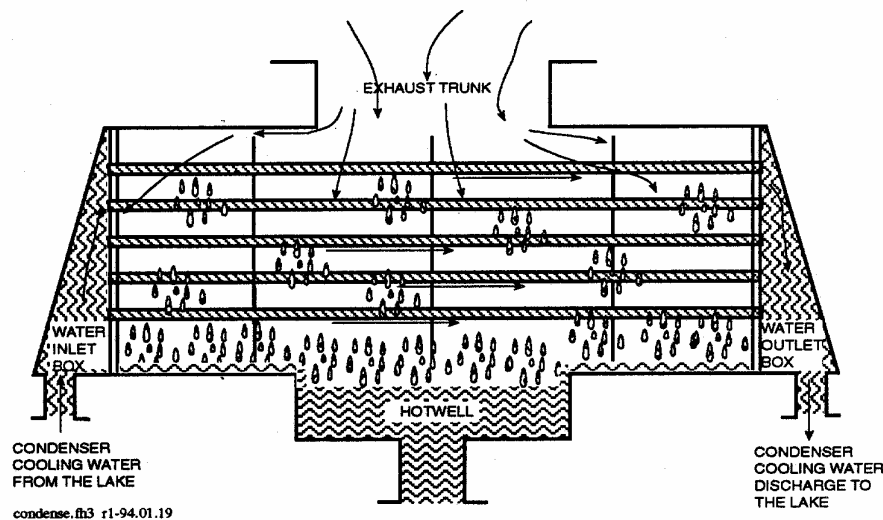

Figure 5.7. Typical Condenser used in CANDU stations.

The CCW flow maintains the saturation temperature of the condensate. This is achieved through proper adjustment of CCW flow. Maintaining the condensate temperature at its saturation point maximizes the retention of the condensate's heat. The lower the turbine exhaust temperature and pressure the greater the amount of steam energy that can be converted into mechanical energy in the turbine. As mentioned, steam leaves the turbine at about 35°C and 5 kPa absolute. This condition is near a perfect vacuum. This allows roughly 35% more energy extraction than if the steam is left at atmospheric pressure (101.3 kPa). The condenser provides the means of maintaining this low absolute pressure at the turbine exhaust through condensation of steam (the 25.2 m³ of steam reduces to 0.001 m³ of water or 25200 times volume reduction).

The steam/feedwater system is a closed loop because it would be wasteful and expensive to reject the clean, chemically treated, demineralized water after it has completed its work in the turbine. It would also be wasteful to throw away the heat held by the 35°C condensate, especially as the CCW flow is adjusted to keep the condensate at saturation temperature and not cool it more than necessary for condensation.

5.5 FEEDWATER SYSTEM

The feedwater system supplies normal feedwater to the steam generators. The feedwater system comprises the main feedwater pumps on Class IV power and a diesel-driven auxiliary feedwater pump. The feedwater is demineralized and preheated light water. The feedwater lines run from the feedwater regulating valve station in the turbine building to the reactor building and hence, to each steam generator.

Figure 5.1 shows a simplified steam system and boiler feedwater system. The feedwater system is generally divided into three parts:

- low pressure feedheating system;
- deaerator and storage tank;
- high pressure feedheating system.

The water leaving the condenser is at relatively low temperature and pressure. A series of heat exchangers raises the condensate temperature to 170°C. The preheaters then increase the temperature to 240°C (almost saturation temperature in the boiler). A set of pumps, known as boiler feed pumps (BFP), force the feedwater into the boilers operating at 4000 kPa.

Low Pressure Feedheating System

The first stage in the boiler feedwater heating is through the LP feedheating system. The condensate extraction pump (CEP) delivers the condensate from the condenser hotwell to the LP feedheaters. The low pressure feedheating system gets its name from the low pressure condition of the feedwater, at about 1400 kPa, compared to the 4000 kPa in the boiler.

The LP feedheaters use extraction steam (wet steam removed from the turbine before it reaches the exhaust end) from the LP turbines as their heating medium. The extraction steam transfers its latent heat of vaporization to the feedwater through a process similar to that in the condenser. A series of low pressure feedheaters heat the feedwater. The extraction steam condenses in the shell of the heater. A separate pump recovers this condensate by pumping it to the condenser hotwell. The feedwater leaves the last LP feedheater at approximately 80°C to 100°C. The heated feedwater then goes to the next stage of the feedheating process.

Deaerator and Storage Tank

The deaerator is the next stage in the feedwater heating process. This is the highest vessel in the system. The deaerator adds heat to and removes non-condensable gases from the feedwater. Some of these gases can increase the corrosion rate of the metals in the high pressure feedheating system and boiler. All non-condensable gases will take-up space in the steam system we wish to occupy with steam.

Figure 5.8 shows a typical deaerator and its associated storage tank. The incoming feedwater enters the deaerator near the top and sprays downward over cascade trays. Extraction steam from the LP turbine enters the deaerator near the bottom and passes upward. As a result the feedwater heats up to about 125°C. The steam passing over the water droplets scrubs the non-condensable gases off their surface. As the extraction steam condenses, the water droplets release the non-condensable gases which are vented to the atmosphere. The deaerated feedwater and condensed steam drain from the deaerator into a storage tank. The storage tank supplies water for boiler operation.

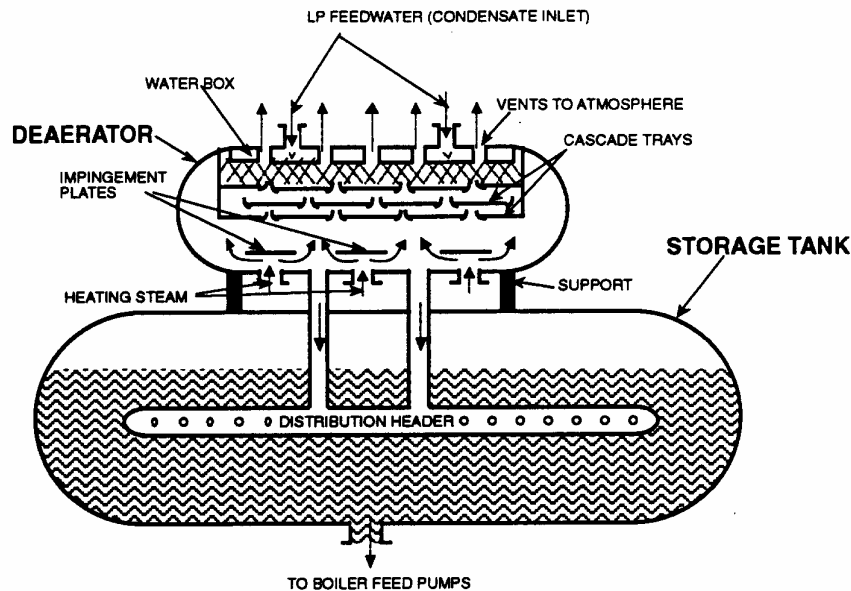

Figure 5.8. Simplified Deaerator and Storage Tank Assembly

High Pressure Feedheating System

From the deaerator storage tank, the feedwater undergoes one more stage of having its temperature and pressure raised. The boiler feed pumps (BFP) take suction from the deaerator storage tank and raise the feedwater pressure to between 4 and 7 MPa. The pump discharges the high pressure feedwater to the high pressure (HP) feedheaters. The HP feedheaters heat the feedwater to about 170°C. HP feedheater operation and construction are similar to that of the LP feedheaters. Extraction steam from the HP turbine normally supplies the heating medium.

The feedwater regulating valve controls the flow of feedwater into the boiler. This valve allows sufficient feedwater to enter the boiler to match the steam flow leaving it, so as to maintain a constant water mass in the boiler. To do this, the controller for the valve compares steam flow out of the boiler with feedwater flow into the boiler and positions the valve to make the two equal. It also compares the actual boiler water level with a predetermined programmed level and positions the valve to make these two equal.

It is critical to maintain a proper boiler level. If the boiler water level is too high, the cyclone separators and scrubbers will not operate properly. This results in wet steam being delivered to the turbine which could lead to damage to the turbine blades. If water level is too low, there would not be enough inventory to cool the heat transport coolant.

CANDU Boiler Feed Pumps and Level Control

Figure 5.9 shows the boiler feed pumps, associated valves, the two high pressure heaters and the steam generator level control valves as configured for a typical CANDU generating station.

Three main boiler feed pumps are required to supply the necessary flow, and one additional pump is on standby. Two auxiliary pumps are also provided, these are sized so that either one can supply the flow to remove decay heat in case of a loss of class IV supply to the main pumps. Connections to the Condensate system allow for re-circulating flow when the pumps are operating but the level control valves are closed.

The level in each steam generator is controlled individually. Since the measured level in a boiler is higher for a given mass of inventory as the power level increases due to the expansion of the water with increased boiling, the level setpoint as well as alarm and trip settings are increased automatically as a function of reactor power.

Because of safety, range of control and maintenance considerations, each steam generator has a set of three control valves for feedwater control connected in parallel: one small valve to control feedwater during shutdown, startup, and low power operation, and two larger valves to control feedwater for on-power conditions. Each of the two large valves can handle the full power flow requirements. Isolating valves are provided for each control valve.

The steam generator level control system balances feedwater to steam flow for all operating conditions: fast reactor runup, reactor setback, turbine trip and 'poison-prevent' mode. The water level setpoint is automatically programmed over a set range as a function of load.

Chemical Control

Boiler steam and feedwater system construction in almost all CANDU stations uses carbon steel, copper alloys and nickel alloys. Each metal is susceptible to corrosion at a different pH level. A compromise pH of 8.8 to 9.3 is relatively safe for all metals involved. Chemical addition at the discharge of the condensate extraction pump ensures the appropriate pH level.

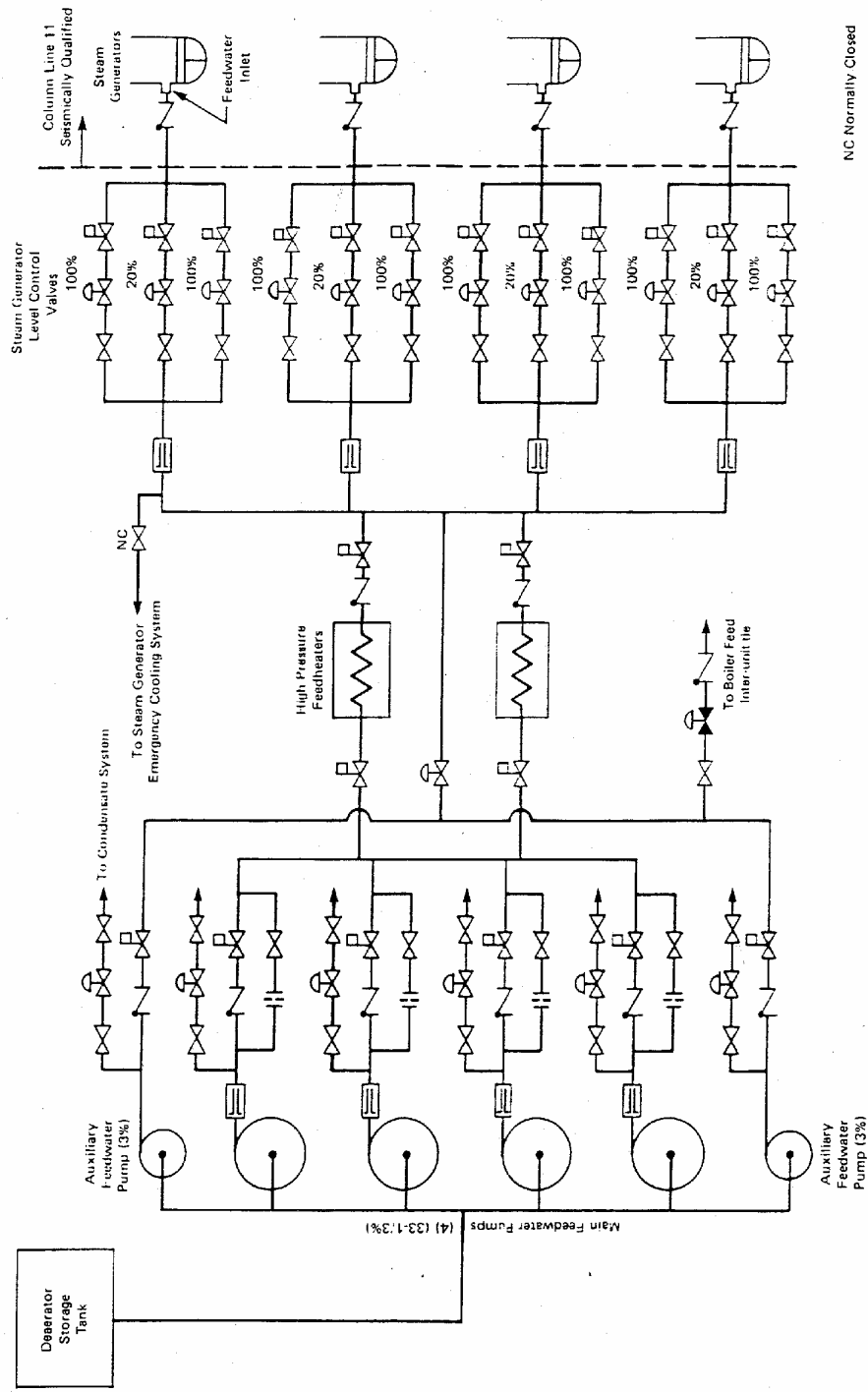

Figure 5.9. Typical CANDU Boiler Feed and Level Control System.

Other methods used to prevent corrosion are:

- oxygen removal from the system,
- chemical addition to react with oxygen.

Most oxygen is removed from the system by the scrubbing action of the deaerator. Hydrazine addition to the feedwater, after the deaerator, removes the remaining oxygen. Its reaction with oxygen produces non-corrosive nitrogen gas and water. Unfortunately, hydrazine also produces ammonia which attacks copper alloys.

High quality feedwater and makeup water is vital as low quality will produce deposits in the boiler and turbine causing:

- reduced heat transfer because of an insulating scale layer on the boiler tube surface;
- increased risk of stress corrosion cracking;
- corrosion of tubes and other components.

All will shorten the life of the boilers and turbines. Demineralization, deaeration, oxygen removal and pH control ensure that we have good quality boiler water. A blowdown system in each boiler allows removal of any impurities that collect in the boilers. This system minimizes accumulation of impurities by draining the contaminated water out of the boiler. Blowdown can be intermittent or continuous, depending on the water condition.

5.6 GENERATOR

Figure 5.10 shows a simplified arrangement of a generator coupled to a steam turbine drive. The stationary conductors (coils) and the associated iron cores are referred to as a stator. Conductors (coils) and the associated iron core mounted on the shaft are referred to as a rotor.

Insulated slip rings on the shaft transfer DC current to create a magnetic field in the rotor. The stator windings act as the conductors for the main generator current while the turbine provides the mechanical torque on the shaft of the generator. The rotating motion provided by the shaft produces the relative motion between the rotor magnetic field and the stator conductors. As a result, a voltage is induced in the stator conductors and transferred to the transmission lines through a step-up transformer.

In a generator, the rotor velocity determines the frequency. When the generator is connected to the grid the frequency is fixed at 50 or 60 Hz depending on the bulk electric system. Since the frequency for the Grid is controlled at a fixed value, the velocity of the rotor is kept constant.

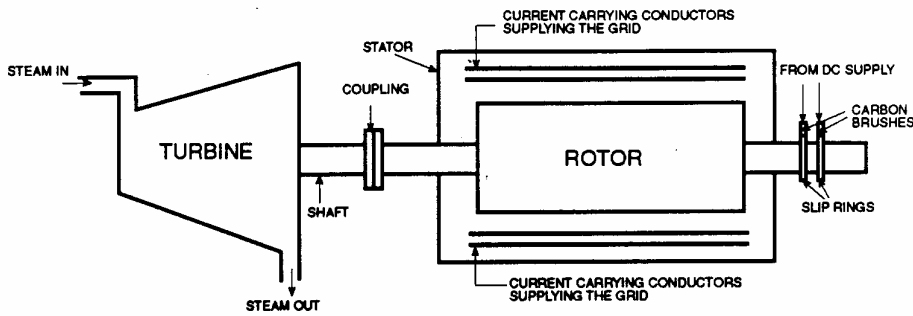

Figure 5.10. Simplified Arrangement of a Generator Coupled to a Turbine Drive.

As electrical consumers use electricity they create a load current on the Grid thereby increasing counter torque to the turbine shaft. The tendency of the turbine is to slow down as counter torque is increased which would decrease the frequency. The governing system senses the decrease in rotational velocity and produces an increased counter torque by admitting more steam to the turbine, thereby producing more shaft mechanical power and maintain the generator speed. In practice, nuclear power plants are seldom used to control Grid frequency, hydraulics and thermal plants with governing systems specifically designed for this purpose would normally have that role. As we have seen in Chapter 1, the Unit Power Regulator would monitor generator output and maintain it at the setpoint by varying the amount of steam flow to the turbine via the governing system, in a manner analogous to that described above, but without any change in generator frequency.

Generator Cooling

The modern electric generator for a steam power station is an extremely efficient machine. Approximately 98% of the mechanical power delivered on the shaft from the turbine is converted to electrical power. The remaining 2% appears as heat in various places in the generator. Two percent does not appear to be very much until you consider that 2% of a 900 MW machine is equal to 18 MW. Since all of this 18 MW is converted to heat, it is like putting a heater of this size inside the generator.

The heat that is produced in a generator comes from several sources including windage (gas friction) between the rotor and the circulating cooling gas, the electrical heating due to the current resistance in the windings of both the rotor and stator, and the electrical heating due to current induced in the structural material of the rotor and stator.

Even small increases in the operating temperature of a generator will lead to rapid deterioration of the insulation on the windings. For this reason, two systems are provided to cool the generator. One system uses hydrogen circulated through the generator. Hydrogen has the advantages of:

- better thermal conductivity than air;
- less damaging to insulation than air;
- less dense than air so less heat is produced from windage.

The disadvantage is that it is explosive when mixed with air. To avoid this hazard, the generator requires very good seals to prevent air in-leakage or leakage of hydrogen out of the generator.

By itself, the hydrogen cooling system is inadequate. To complement it, a stator cooling water system is also provided. The conductors in the stator are hollow and water is circulated through them. This water has to be exceptionally pure to prevent leakage of current from the stator conductors to ground through the coolant.

Turning Gear

When a turbine comes to rest, after operating, the cooler and denser steam tends to collect in the lower half of the cylinder and makes the lower half of the rotor cool quicker than the upper half. This causes the shaft to 'hog' (bend upwards). When at rest and cool, the shaft will begin to 'sag' under its own weight. If the turbine shaft is not rotated, hogging, especially above a critical temperature, can become permanent and the shaft would have to be sent to the manufacturer for heat treatment and straightening. Sagging does not usually become permanent but it takes time to recover the sag. To prevent a bent shaft due to sag or hog the shaft is rotated by a turning gear which is a motor driven gear train mechanism on the turbine generator shaft.

Lubrication System

Each unit of the turbine and the generator has its own rotor/shaft that is supported at each end by journal bearings. Journal bearings get hot due to friction and heat conduction along the shaft from hot parts of the turbine. The journal bearings are normally lined with white metal known as antifriction metal or babbitt, which is a lead-tin alloy with a melting point that can be as low as 182°C. A centralized lubricating system is employed to protect the bearings from damage due to metal to metal contact and high temperature. This extends the life of the bearings and reduces the chance of failure. A bearing failure is a very serious incident as far as the turbine-generator is concerned and would cause extensive damage. For this reason it is always important to have sufficient oil flow through the bearings for lubrication and cooling purposes.

5.7 CONVENTIONAL PLANT SERVICES

Conventional plant services include water supply, heating, ventilation, air conditioning, chlorinating, fire protection, compressed gases and electric power systems.

The water supply systems provide cooling water, demineralized water and domestic water to station users.

Heating, ventilation and air conditioning is provided to ensure a controlled environment during winter and summer.

Chlorination systems are used for treatment of domestic water, fresh water supply to the pre-treatment plant, condenser cooling water and raw service water. Separate chlorination systems are provided, in the water treatment plant, in the Group 1 pumphouse, and the Group 2 pumphouse.

Compressed gas systems supply compressed air, helium, nitrogen and carbon dioxide gases, and vacuum to all plant systems as required.

Provision is made to detect heavy water in the steam. Connections from each steam line to the D₂O in light water detection system provide a continuous on-line measurement capability. Each sampling line also has a low pressure low temperature grab sample valve for periodic assessment of steam chemistry and tritium content.

Copyright information for Chapter 5:

Figures on pages 5-7 and 5-15 are from CANDU® 9 480/NU Technical Description, AECL document 69-01371-TED-001 Rev. 1, January 1995. Reprinted with permission of Atomic Energy of Canada Limited (AECL).

Figures on pages 5-2, 5-4, 5-5, 5-10, 5-11, 5-13 and 5-10 are from unpublished training documents of Ontario Hydro. Reprinted with permission.

CHAPTER 6

SPECIAL SAFETY SYSTEMS

CHAPTER OBJECTIVES:

At the end of this chapter, you will be able to describe the following features of the special safety systems:

1. The main functions and unique requirements of the special safety systems;
2. The functions, equipment and operation of shutdown systems number 1 and number 2;
3. The functions, equipment and operation of the emergency core cooling system;
4. The functions, equipment and operation of the containment system.

This chapter describes the basic design and operating practices used to ensure the safe operation of nuclear power plants, and in particular to prevent the release of unsafe amounts of radioactivity to the environment. It deals in detail with the four special safety systems that are used in CANDU generating units to ensure reactor safety.

6.1 SHUTDOWN SYSTEM REQUIREMENTS

The two reactor shutdown systems are designed in compliance with Regulatory Requirements for Shutdown Systems for CANDU Nuclear Power Plants, having the following characteristics:

- For events requiring prompt shutdown action, each shutdown system, acting alone, must ensure that
 - the reactor is rendered subcritical and maintained subcritical,
 - the reference dose limits are not exceeded, and
 - the integrity of the heat transport system is maintained (excluding any initiating LOCA). Emergency core cooling and containment functions may be credited as appropriate.
- For relevant events listed in Table 6.1 each shutdown system must ensure that fuel in the reactor, with no defects prior to the event, does not fail as a consequence of the event (excluding fuel in a ruptured channel).
- Each shutdown system is environmentally qualified to the most severe conditions under which it is required to function.
- Each shutdown system meets an unavailability target of less than 1×10^{-3} .
- The two shutdown systems incorporate the principles of redundancy, diversity, testability and separation throughout their design.
- The two shutdown systems are independent of the regulating and process systems.

For purposes of assessing the performance of shutdown system number 1, the following conservative requirements are used:

- For all relevant process failures (see Table 6.1), the shutdown system number 1, with the two most effective shutdown rods assumed unavailable, shall have sufficient speed and negative reactivity depth to reduce the reactor power to levels consistent with available fuel cooling.
- For an in-core loss-of-coolant event, the shutdown depth shall be adequate to shut down the reactor and maintain a shutdown state until operator action can be credited. In assessing shutdown depth the two most effective rods are assumed to be unavailable and any rods damaged by the event are not credited.

For purposes of assessing the performance of shutdown system number 2, the most effective poison injection nozzle is assumed unavailable. The remaining nozzles shall have sufficient speed and negative reactivity depth to reduce the reactor power to levels consistent with available fuel cooling for all process failures identified in Table 6.1

The reactor may not be operated at power, if either shutdown system number 1 or shutdown system number 2 is known to be unavailable.

Table 6.1. Coverage of Process Failures by Shutdown System Number 1 and Independently by Shutdown System Number 2.

No.	Process Failure	Trip Parameter	Alternative Trip Parameter
Loss of Regulation from High Power:			
1.	Fast	High Rate Neutron Power	High Neutron Power/High Heat Transport Pressure
	Slow	High Neutron Power	High Heat Transport Pressure/Manual ⁽¹⁾
Loss of Regulation from Decay Power Levels:			
2.	Pressurized/Pumps On		
	Fast	High Rate Neutron Power	High Heat Transport Pressure
	Slow	High Heat Transport Pressure	High Neutron Power ⁽¹⁾ Manual ⁽¹⁾
3.	Pressurized/Pumps Off		
	Fast	High Rate Neutron Power	Low Gross Coolant Flow ^{(2) (6)}
	Slow	Low Gross Coolant Flow ^{(2) (6)}	High Heat Transport Pressure
4.	Reduced Pressure/Pumps Off		
	Fast	High Rate Neutron Power ^{(2) (6)}	Low Heat Transport Pressure/Low Gross Coolant Flow ^{(2) (6)}
	Slow	Low Gross Coolant Flow ^{(2) (6)}	Low Heat Transport Pressure ^{(2) (6)} /Manual ⁽¹⁾
5.	Reduced Pressure/Pumps On		
	Fast	High Rate Neutron Power	Low Heat Transport Pressure ^{(2) (6)}
	Slow	Low Heat Transport Pressure ^{(2) (6)}	Manual
6.	Loss of Class IV Power	Low Gross Coolant Flow ⁽²⁾	High Heat Transport Pressure

Table 6.1. (Continued) Coverage of Process Failures by Shutdown System Number 1 and Independently by Shutdown System Number 2.

No.	Process Failure	Trip Parameter	Alternative Trip Parameter
Loss of Coolant Into Containment:			
7.	Large	High Rate Neutron Power	High Neutron Power/High reactor building Pressure
8.	Intermediate	High Neutron Power	High reactor building Pressure
9.	Small		
	With Regulation	High reactor building Pressure	Low Heat Transport Pressure ⁽²⁾ /Low Pressurizer Level
	With Regulation - Pressurizer Isolated	High reactor building Pressure	Low Heat Transport Pressure
	Without Regulation	High reactor building Pressure	High Neutron Power
10.	Very Small		
	With Regulation	Low Heat Transport Pressure ⁽²⁾	Low Pressurizer Level/Manual
	With Regulation-Pressurizer Isolated	Low Heat Transport Pressure ⁽²⁾	Manual
	Without Regulation	High Neutron Power	Manual ⁽¹⁾
11.	Loss-of-Coolant Into Calandria		
	With Regulation	Low Heat Transport Pressure ⁽²⁾ Moderator High Level	Low Pressurizer Level/Manual ⁽¹⁾
	With Regulation - Pressurizer Isolated	Low Heat Transport Pressure ⁽²⁾ Moderator High Level	Manual ⁽¹⁾
	Without Regulation	High Neutron Power Moderator High Level	Manual ⁽¹⁾

Table 6.1. (Continued) Coverage of Process Failures by Shutdown System No. 1
 and Independently by Shutdown System No. 2

No.	Process Failure	Trip Parameter	Alternative Trip Parameter
Secondary Side Failures:			
12. Steam Main Break with Feed Pumps On	Inside Containment	High reactor building Pressure	Low steam generator Level ⁽¹⁾ / Low steam generator Feedline Pressure ⁽⁵⁾ / Low Heat Transport Pressure
	Outside Containment	Low steam generator Level	Low Heat Transport Pressure ⁽¹⁾⁽⁴⁾ / Low steam generator Feedline Pressure ⁽¹⁾⁽⁴⁾ / Manual ⁽¹⁾
13. Steam Main Break with Feed Pumps Off	Inside Containment	High reactor building Pressure	Low steam generator Feedline Pressure ⁽¹⁾⁽⁴⁾ / Low steam generator Level ⁽¹⁾
	Outside Containment	Low steam generator Feedline Pressure ⁽⁴⁾⁽³⁾	Low steam generator Level / High Heat Transport Pressure ⁽¹⁾
	14. Feedline Break Upstream of Check Valves	Low steam generator Feedline Pressure ⁽⁴⁾⁽¹⁾	Low steam generator Level, High Heat Transport Pressure, Manual
	Downstream of Check Valves	High reactor building Pressure	Low steam generator Level / Low steam generator Feedline Pressure ⁽¹⁾⁽⁴⁾ / High Heat Transport Pressure ⁽³⁾⁽¹⁾ / Manual ⁽¹⁾

Table 6.1. (Continued) Coverage of Process Failures by Shutdown System Number 1 and Independently by Shutdown System Number 2.

No.	Process Failure	Trip Parameter	Alternative Trip Parameter
15.	Loss of Feedwater Control (e.g., Closure of Feedwater Valves to a steam generator)	Low steam generator Level	High Heat Transport Pressure ⁽³⁾⁽¹⁾ /Manual ⁽³⁾
16.	Feedwater Pumps Trip	Low Steam generator Level	High Heat Transport Pressure ⁽³⁾⁽¹⁾ / Low steam generator Feedline Pressure ⁽¹⁾⁽⁴⁾
17.	Loss of Moderator Cooling	High Moderator Level	Manual
18.	Moderator Pipe Break	Low Moderator Level	Manual/High Neutron Power

Notes:

- (1) Alternative trip parameters which provide trip coverage over a limited range of event scale (e.g., break size).
- (2) The low coolant flow and low heat transport system pressure trips are conditioned out on log power < 0.3 percent.
- (3) If 4 percent feedwater flow is available after trip.
- (4) The low steam generator feedline pressure trip is conditioned out when log power < 10 percent.
- (5) Feedline pressure may precede steam generator low level.
- (6) Trip acts as high power trip in effect since power is increasing - this instigates a trip by removing the conditioned-out state.

6.2 SHUTDOWN SYSTEM NUMBER 1

The primary method of quickly terminating reactor operation when certain parameters enter an unacceptable range, is the release of the spring-assisted gravity-drop shutdown rods of shutdown system number 1. Shutdown system number 1 employs a logic system having three independent channels, designated D, E and F, which detect the requirement for reactor trip and de-energize direct current clutches to release the shutdown rods into the moderator region of the reactor core.

Reactor and Process Measurements

The design philosophy is based on triplicated measurements of each variable, with protective action initiated when any two of the three trip channels are tripped. A single loop component or power supply failure will not incapacitate or spuriously invoke the operation of the safety system.

As indicated in Table 6.2 there are nine types of measured variables which can initiate a reactor trip through shutdown system number 1. The selection of variables is such that, to the maximum extent practicable, there are redundant sensing parameters for all categories of process failures identified. The reactor trip can also be manually initiated by the operator from the main control room or from the secondary control area. The nine measured variables are described separately below:

a. Neutron Power

Inconel in-core flux detectors are provided in each of channels D, E, and F for overpower or loss-of-regulation protection. The detectors are located in the vertical in-core flux detector assemblies. The detectors are of the straight individually replaceable type and are three lattice pitches long. A linear amplifier converts each detector current to a corresponding voltage signal.

Abnormal reactor operating conditions are accounted for by lowering the trip setpoint on all detectors by a predetermined amount. This is done through a safety system console.

The type of loss-of-regulation incident that determines the locations and trip setpoints for the in-core detectors is a slow uncontrolled power increase, starting from various initial flux shapes. The flux shapes used to design the neutron overpower trip are chosen to ensure coverage of any flux shape that could arise during normal maneuvering of the reactor or from any single device failure.

Test facilities are provided to check the trip circuit by adding a test current to the normal detector current on the amplifier input, and to check the insulation resistance of each detector. The detector outputs can be displayed on cathode ray tubes in the main control room and the secondary control area for purposes of monitoring the signals, at the command of the operator.

b. Rate of Logarithmic Neutron Power

This parameter uses ion chambers, located in separate housings on one side of the calandria. The ion chambers provide a current signal which is proportional to the thermal neutron flux. The output current from each ion chamber goes to an amplifier which produces linear and logarithmic neutron power, and rate logarithmic signals; the latter is used as a direct trip parameter.

c. Heat Transport System Flow

Heat transport system flow is measured in a number of feeders. Flow readings from half of these feeders are used for shutdown system Number 1 while the other half are used for shutdown system Number 2. The logic is arranged such that each trip channel has measurements from each coolant pass. The trip is conditioned out automatically at very low power or shutdown conditions.

The flow elements are installed in a horizontal run of the inlet feeder to the specified fuel channels. Flow transmitters are mounted on the three channelized instrument racks.

d. Heat Transport System Pressure

Heat transport system pressure is measured at three widely separated locations on each reactor outlet header. The pressure transmitters are mounted on channelized instrument racks. Regular loop testing is conducted from the main control room. Both high pressure and low pressure are used as trip signals. The low pressure trip is conditioned out automatically at low power level.

These pressure transmitters also provide the signal for the heat transport liquid relief valves.

e. Reactor Building Pressure

This parameter uses a triplicated measurement of the reactor building pressure. It is effective for primary and secondary side breaks within containment.

f. Pressurizer Level

Low pressurizer level is a trip parameter effective for small loss-of-coolant accidents. Triplicated level measurements (D, E, F) are provided on the pressurizer for this trip. The trip is conditioned out automatically at very low power levels to allow for draining the pressurizer during maintenance.

g. Steam Generator Level

The steam generator low level trip provides protection against secondary side failures. Triplicated level measurements (D, E and F) are provided on each steam generator. The trip is conditioned out automatically at low power level.

h. Steam Generator Feedline Pressure

Each channel monitors the pressure in each steam generator feedline between the feedwater control valve station and the steam generator. This trip parameter protects against secondary side failures which could result in the loss of the steam generators as a heat sink. The trip is conditioned out automatically at low power level.

i. Moderator Level

Moderator level is a trip parameter effective for loss of moderator cooling, moderator pipe breaks and channel failures (i.e., in-core loss-of-coolant accidents). Triplicated level measurements (D, E, F) are provided to measure the level on the calandria for trips on both low and high level.

Table 6.2. Shutdown System Number No. 1 Trip Parameters

Item	Trip Parameter	Detector
a.	Neutron Power	Vertical In-Core Detectors
b.	Rate Log Neutron Power	Ion Chambers
c.	Heat transport system Flow	Differential Pressure Transmitters
d.	Heat transport system Pressure	Pressure Transmitters
e.	Reactor building Pressure	Differential Pressure Transmitters
f.	Reactor building Pressure	Differential Pressure Transmitters
g.	Steam generator Level	Differential Pressure Transmitters on each steam generator
h.	Steam generator Feedline Pressure	Pressure Transmitters on Individual Feedlines
i.	Moderator Level	Differential Pressure Transmitters

Logic Processing and Testing

There are three independent channels, D, E and F, having completely independent and physically separated power supplies, trip parameter sensors, instrumentation, trip computers, and annunciation. Shutdown system number 1 uses general coincidence voting logic; i.e. the shutdown rods are dropped when any two of the three channels trip, regardless of the parameters causing the channel trips. A simplified block diagram of one channel is shown in Figure 6.3.

The trip system is monitored to provide a positive indication of the state of the trip logic, by verifying the correct operation of all contacts when each channel is tested.

The shutdown units are divided into two banks: each bank is supplied with redundant (90 V(dc) to 110 V(dc)) power supplies for the clutches. Each clutch coil is held energized by the contacts of a separate relay. The high volt-ampere rating of the clutch dictates this arrangement to ensure no relay contact overrating.

For each variable monitored, a test capability is provided by which a trip condition is simulated, establishing that the channel and parameter trip logic function as designed. The testing frequency is determined based on the target unavailability for each parameter.

Shutdown Rod Withdrawal and Drop Test

Normal withdrawal is controlled by the regulating system. The shutdown rods are withdrawn as soon as the trip signal has been cleared and the trip has been reset by the operator. All shutdown rods are withdrawn simultaneously. Withdrawal of the shutdown rods is interrupted if control is switched to manual, or the flux power error is excessive, or the reactor is tripped. If the log-rate exceeds 7 percent per second, the withdrawal of the shutdown rods is also interrupted. The computer monitors the withdrawal time and, if it is greater than normal, the 'shutdown rod stuck' signal is generated.

An individual rod may be selected for manual control at any time for drop testing or drive.

Withdrawal of the rods by banks in the manual mode is possible when the automatic control is not available. The motor and drive circuits are electrically independent of the clutch circuits, ensuring effective separation of the regulating and safety functions.

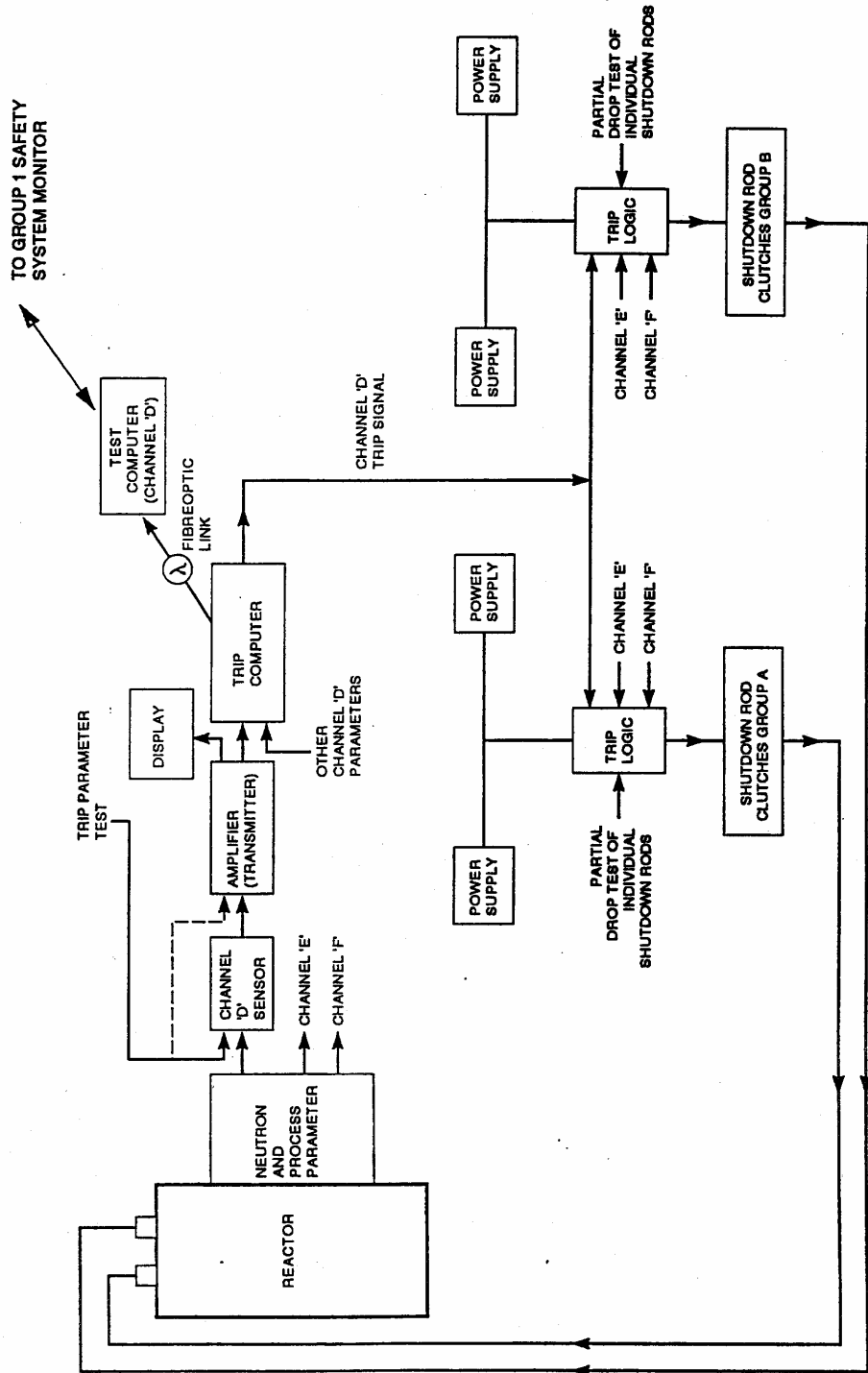

Figure 6.3. Shutdown System Number 1 - Block Diagram.

A partial drop test facility is provided in the clutch circuit to allow the operation of each shutdown rod to be checked during reactor operation. There is a time delay relay for each shutdown rod, which is set during commissioning, to de-energize the clutch relay for sufficient time to allow the shutdown rod to drop a defined distance. The position of the shutdown rod after the test is recorded to determine whether there has been any change in the shutdown unit performance.

Equipment Layout

The shutdown unit drive mechanisms are located on the reactivity mechanism deck. This permits controlled access to the clutches, motors, potentiometers, gearboxes and winches for removal or for maintenance one at a time.

There are separate cables and junction boxes for the clutch circuits and the motor drive circuits, to maintain separation between the regulating and shutdown system channels.

The trip computers and other trip logic for each channel of shutdown system number 1 are located in the main control area.

All of the reactor measuring devices on shutdown system number 1 are field-mounted in a manner which minimizes the possibility of common-mode failures with the devices used for shutdown system number 2 and for the regulating system. The connecting cables are routed to the shutdown system number 1 trip logic equipment in the main control area, in three separate channelized cable runs.

Instrumentation and Power Supplies

All the information required on the tripping parameters and the status and operation of the system is available for display on video display units in the main control room.

Separately channeled Group 1, Class II power supplies are provided for each channel of shutdown system number 1.

The direct current clutches, operated from rectified, redundant Class III power, release on loss of power.

A reactor trip occurs on a loss of power to two or more channels. Power loss to a channel results in an irrational signal to the trip computer, and a channel trip.

When a parameter reaches the trip level, the system indicates an alarm state until the operator resets. The status of all trip parameters is sent to the plant display system through a fiber-optic link for annunciation and event sequencing. During upset conditions, the time and sequence of various parameters exceeding their limits can be printed out on demand.

Trip Computers

The trip logic and trip testing for both shutdown systems make use of trip and test computers in the main and secondary control areas and video display units and console in the main control room.

Figure 6.3 shows how the trip computers and test computers are used in the trip logic for shutdown system number 1. Figure 6.4 shows the configuration of fully computerized shutdown systems. Links shown in dotted lines are normally disabled; external interlocks ensure that only one trip channel can receive information at any given time.

One trip computer per channel is used in each shutdown system. The trip computers replace all analog trip comparators, all programmable digital comparators and relay logic which was used in previous plants. The final two out of three voting continues to be done using relays.

Video Display Units

The video display units provide significant improvement over panel meters for the following reasons:

- Multiple process signals for the same trip parameter (e.g., levels in various steam generators) are grouped under similar scales and headings, making it easy to find desired measurements.
- Numeric display of measurements give a high degree of reading accuracy.
- Graphical bar charts allow quick evaluation of measurements relative to setpoints and other similar signals.
- Margin-to-trip indication is provided.
- The trip condition of each signal is highlighted, supplementing the window alarms and giving more detail as to which measurement caused the trip.
- Messages are used to identify abnormal conditions such as conditioning status, irrational measurements, etc. Similar information from the annunciation system may not persist due to flooding of alarm messages during plant upsets.

The video display unit receives all necessary information from the trip computer via a unidirectional serial data link. Uni-directional data transmission is used to prevent video display unit faults from propagating back to the trip computer. The fiber-optic link ensures electrical isolation and immunity to electromagnetic interference.

The system performs, under operator control via the safety system monitor computers, the periodic testing of trip logic. It will report to the operator all relevant test results and produce a permanent printed record. Suitable interlocks ensure that only one channel in a shutdown system can be under test at one time. If abnormal conditions occur during a test, the system will automatically cancel the test.

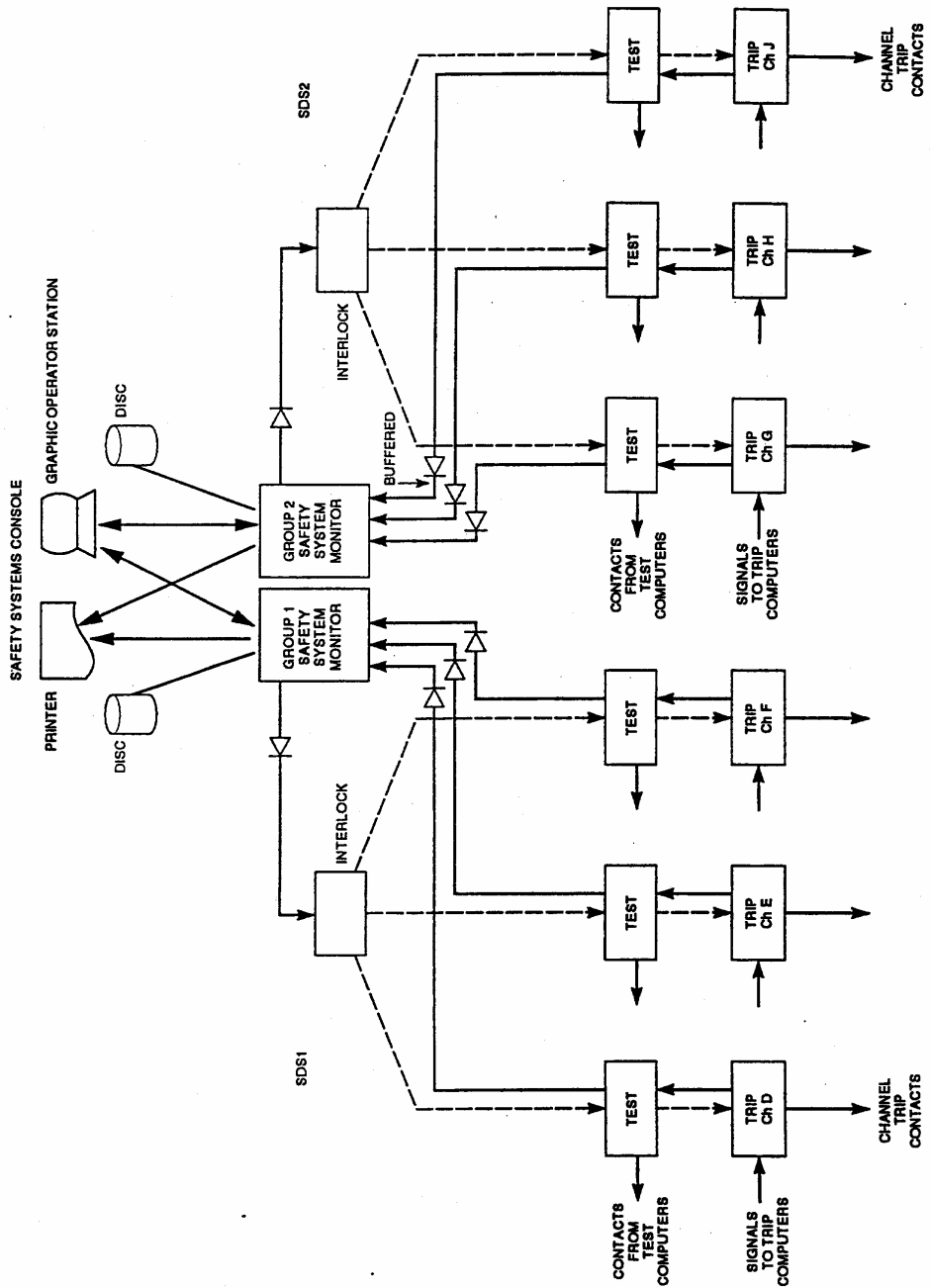

Figure 6.4. Configuration of Fully Computerized Shutdown Systems.

Design Evaluation

The required shutdown system number 1 reactivity insertion time is less than or equal to two seconds.

The variation of the dynamic reactivity worth of shutdown rods with distance inserted is shown schematically in Figure 6.5. The calculations are made with a three-dimensional two-energy group neutron kinetics code, with reactor model that includes the effect of the calandria notch region, nominal zone controller insertion and all adjuster rods fully inserted.

In general, changes in lattice properties and their influence on shutdown margin are negligible throughout the life of the plant. The most reactive condition occurs when the fuel is fresh and approximately 10 mk of positive static reactivity appears after shutdown because of the cooling of the fuel. However, depleted/natural uranium is usually used for the initial case load.

The effectiveness of shutdown system number 1 is evaluated on the basis of the two most effective shutdown rods being unavailable.

The required unavailability of shutdown system number 1 is 1×10^{-3} or less on the following basis: any two of the shutdown rods fail to operate as designed and each trip parameter provides two-out-of-three trip signals. No credit is taken in the unavailability analysis for trip signals from alternative trip parameters.

Operation

The tripped condition or unavailability of shutdown system number 1 (more than two shutdown rods not fully withdrawn) inhibits moderator poison removal, and adjuster and mechanical control absorber withdrawal, and isolates the moderator system D₂O supply lines to prevent addition of pure D₂O to a poisoned moderator. The tripped condition of shutdown system number 2 inhibits withdrawal of the shutdown rods.

6.3 SHUTDOWN SYSTEM NUMBER 2

Shutdown system number 2 is the second method of quickly terminating reactor operation when certain parameters enter an unacceptable range. This is via the rapid injection of concentrated gadolinium nitrate solution into the moderator through horizontal nozzle assemblies. Shutdown system number 2 employs a logic system with three independent channels which sense the requirement for shutdown and signal the opening of fast-acting valves which release high pressure helium to inject the gadolinium poison into the moderator.

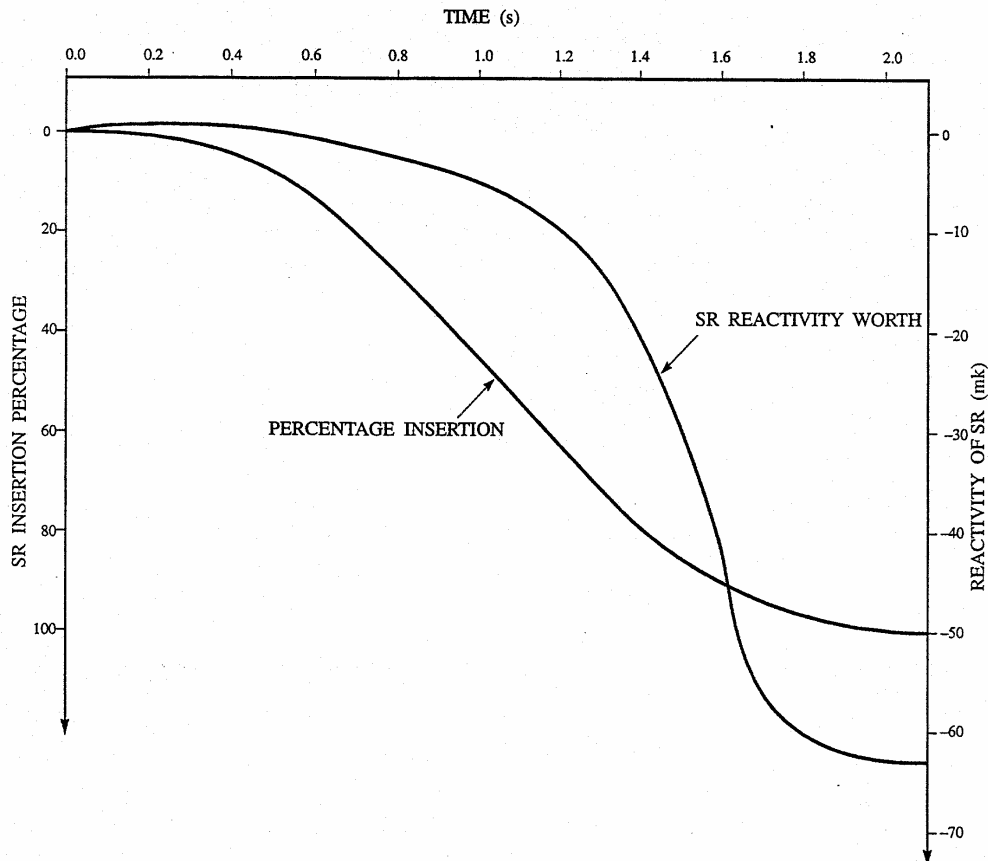

Figure 6.5. Shutdown Rod (SR) Insertion and Reactivity Worth.

Reactor and Process Measurements

The design philosophy is based on triplicating the measurement of each variable and initiating protective action when, for the same parameter, any two of the three exceed their setpoint (i.e., local coincidence logic). A single loop component or power supply failure will not incapacitate or spuriously invoke the operation of the safety system.

There are nine measured parameters which can initiate a reactor shutdown through shutdown system number 2, as shown in Table 6.3. The selection of parameters is such that, where practicable, there are redundant sensing parameters for all categories of process failures identified. Refer to Table 6.1. The system can also be manually tripped by the operator from the main control room or the secondary control area. The nine measured parameters are described separately in Table 6.3.

Table 6.3. Shutdown System Number 2 Trip Parameters and Detectors Used.

Item	Trip Parameter	Detector
a.	Neutron Power	Vertical In-Core Detectors
b.	Rate Log Neutron Power	Ion Chambers
c.	Heat transport system Flow	Differential Pressure Transmitter
d.	Heat transport system Pressure	Pressure Transmitter
e.	Reactor building Pressure	Differential Pressure Transmitter
f.	Reactor building Pressure	Differential Pressure Transmitter
g.	Steam generator Level	Differential Pressure Transmitter on each steam generator
h.	Steam generator Feedline Pressure	Pressure Transmitter on Individual Feedlines
i.	Moderator Level	Differential Pressure Transmitter

Neutron power

Horizontal in-core flux detector assemblies enter the calandria on the ‘D’ side of the reactor, refer to Figure 2.4. The detectors are divided between channels G, H and J, are three lattice pitches long, and are of the straight individually replaceable Inconel type. These detectors are separated from any regulating system and shutdown system number 1 detectors by virtue of the spatial separation and orientation of the assemblies.

The type of loss-of-regulation incident that determines the locations and trip setpoints for the in-core detectors is a slow uncontrolled power increase starting from various initial flux shapes.

The flux shapes used to design the neutron overpower trip are chosen to ensure coverage of any flux shape that could arise during normal maneuvering of the reactor or from any single device failure.

The output current of each detector goes to a linear amplifier. The design of these amplifiers is different from that used on shutdown system number 1.

Abnormal operating conditions are accounted for by lowering the trip setpoint on all detectors by a predetermined ratio. This is done via channelized shutdown system number 2 console pushbuttons in which a single pushbutton reduces all detector setpoints in a specific channel.

Test facilities are provided to check the trip circuit by injection of a test current in parallel with the detector to the amplifier, and to check the insulation resistance of each detector. The detector outputs and trip setpoints can be displayed on video display units in the main control room and the secondary control room for purposes of monitoring the signals at the operator's command.

Rate of logarithmic neutron power

This parameter uses uncompensated ion chambers, located in separate housings attached to one side of the calandria. Lead shielding is provided between the inner end of the ion chambers and the outside of the calandria. The outer ends of the ion chamber tubes extend through the side wall of the reactor vault, where they are sealed by bellows.

The test shutter is the conventional piston-operated boral sleeve and has the capability of increasing the flux to the ion chambers by approximately 40 percent. The piston speed is adjustable to provide the necessary neutron rate signals. Shutter tests initiated from the main control room check a shutdown system number 1, a shutdown system number 2 and a regulating system ion chamber. Shutdown system number 1 and shutdown system number 2 ion chambers are on opposite sides of the reactor.

Heat transport system flow

Heat transport system flow is measured in a number of feeders. Flow readings from half of these feeders are used for shutdown system number 1 while the other half are used for shutdown system number 2. The logic is arranged such that each trip channel has measurements from each coolant pass. The trip is conditioned out automatically at very low power or shutdown conditions.

The flow elements are installed in a horizontal run of the inlet feeder to the specified fuel channels. Flow transmitters are mounted on the three channelized instrument racks.

Heat transport system pressure

Heat transport system pressure is measured at three widely separated locations on each reactor outlet header. The pressure-e transmitters are mounted on channelized instrument racks. Regular loop testing is conducted from the main control room. Both high pressure and low pressure are used as trip signals. The low pressure trip is conditioned out automatically at low power level.

Reactor building pressure

This parameter uses a triplicated measurement of the reactor building pressure. It is effective for primary and secondary side breaks within containment.

Reactor building pressure is normally held slightly negative with respect to atmospheric by the reactor building ventilation system. If the pressure rises above the setpoint, the reactor will be tripped.

Pressurizer level

Low pressurizer level is a trip parameter effective for small loss-of-coolant accidents. The trip is automatically conditioned out at very low power levels to allow for draining of the pressurizer during maintenance. Triplicated level-measuring loops G, H and J are provided from the pressurizer.

Steam generator level

The steam generator low level trip provides protection against secondary side failures. Triplicated level measurements (G, H and J) are provided on each of the steam generators. The trip is conditioned out automatically at low power level.

Steam generator feedline pressure

Channels G, H and J measure the pressure in the steam generator feedlines between the feedwater control valve and the steam generator. This trip parameter protects against secondary side failures which could result in the loss of the steam generators as a heat sink. The trip is conditioned out automatically at low power level.

Moderator level

The moderator level trip provides protection against pipe failure in the moderator system, loss of moderator cooling and channel failure (i.e. in-core loss-of-coolant accident). Triplicated level management (G, H, J) are provided on the calandria for both low and high level trips.

Logic Processing and Testing

There are three independent channels, G, H and J. Local coincidence is used, that is, for the same parameter, two-out-of-three exceeding their setpoint will initiate poison injection.

Figure 6.6 shows a simplified block diagram of one channel of the liquid poison injection system.

There are two alternate helium paths, each with injection valves and an interspace vent valve. Logic ensures that the interspace between the helium injection valves is depressurized to prevent spurious, partial injection, during testing.

For each variable monitored, a test capability is provided by which a trip condition is simulated establishing that the channel trip logic for that parameter functions as designed. In addition, trip parameter measurements are tested by a check for insulation resistance for the in-core flux detectors and by a monitoring and channelized cross-comparison process for process pressure measurements. Similar channelized measurements of routine pressure fluctuations are cross-compared using the monitoring computer to determine if any one of the transmitters is not responding properly to variation in the measured variables.

Testing frequencies are determined on the basis of target unavailability for each parameter.

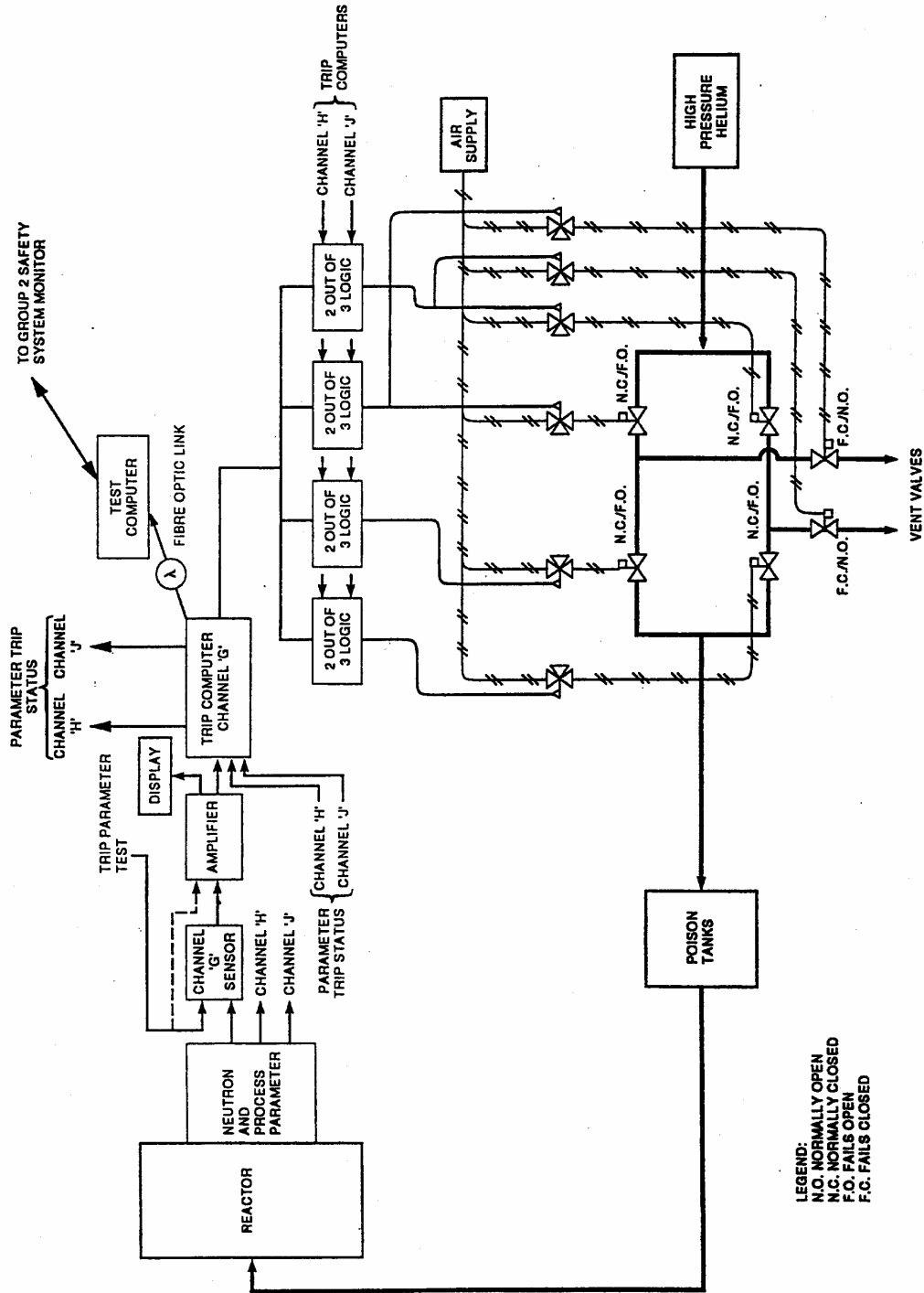

Figure 6.6. Shutdown System Number 2 - Block Diagram.

Liquid Poison Injection System

Figure 6.7 shows a simplified schematic diagram of the Liquid Poison Injection system. A vessel containing high pressure helium supplies the energy for rapid poison injection. The tank is connected, through four quick-opening valves arranged in two successive pairs, to a helium header which services the poison tanks. The quick-opening valves are air-to-close, spring-to-open, so that they fail safe on loss of air supply or electrical power. The cylindrical poison tanks are mounted on the outside wall of the reactor vault. Each of these poison tanks contains gadolinium nitrate solution. The nominal solution concentration is verified by an on-line re-circulating sampling system.

Each poison tank is connected by a stainless steel pipe to a horizontal in-core injection tube nozzle which spans the calandria and is immersed in the moderator. The Zircaloy-2 nozzles penetrate the calandria horizontally and at right angles to the fuel channel tubes. Holes are drilled into the nozzle along its length to form four rows of jets which facilitate complete dispersion of the poison into the moderator.

There is a liquid-to-liquid interface between the poison solution and the moderator at the ball isolation valve in the piping downstream from each poison tank. Movement of the interface is caused by the poison very slowly migrating by diffusion from an area of high concentration to an area of low concentration. Also, physical motion of the liquid back and forth in the line causes a small amount of mixing of the poison solution with the moderator. This motion is caused by variations in the moderator level. The interface movement results in a periodic requirement for back flushing (moving of poison back to design position) approximately twice per year. This procedure is required infrequently because of the slow diffusion process and because the moderator level in the moderator head tank is maintained constant during warm-up and upgrading by bleed and feed respectively from the D₂O supply system. Also moderator temperature is maintained constant during operation.

Two conductivity probes are installed in each poison injection line downstream of the poison tank. One is located close to the bottom of the poison tank to monitor the poison concentration and alarm on low poison concentration. The second probe is located close to the bellows assembly of the shield tank to detect when the poison solution reaches the downstream top of the U-section. If an alarm is received from any of the latter probes, the associated poison injection line must be back-flushed to pull the poison interface back to the ball valve or drain line inside the vault.

In the back-flushing procedure, the affected poison tank is partially drained to the mixing tank with the ball valve in the poison injection line closed. This valve is then opened and the interface moves towards the poison tank, refilling it. Finally, the affected poison tank is drained and refilled with gadolinium nitrate solution from the mixing tank. The contents of the mixing tank must be sampled using the re-circulating sampling system immediately before it is transferred to a poison tank, to verify that the poison solution has the correct concentration. A sample is also needed before adding concentrated poison solution to the mixing tank, to establish how much concentrate is needed to bring the concentration of the solution in the tank up to the required value. The sampling system can take samples from a selected poison tank while the reactor is operating without removal of the tank from service. This procedure ensures that the poison concentration in the poison tanks remains uniform and at an acceptable value.

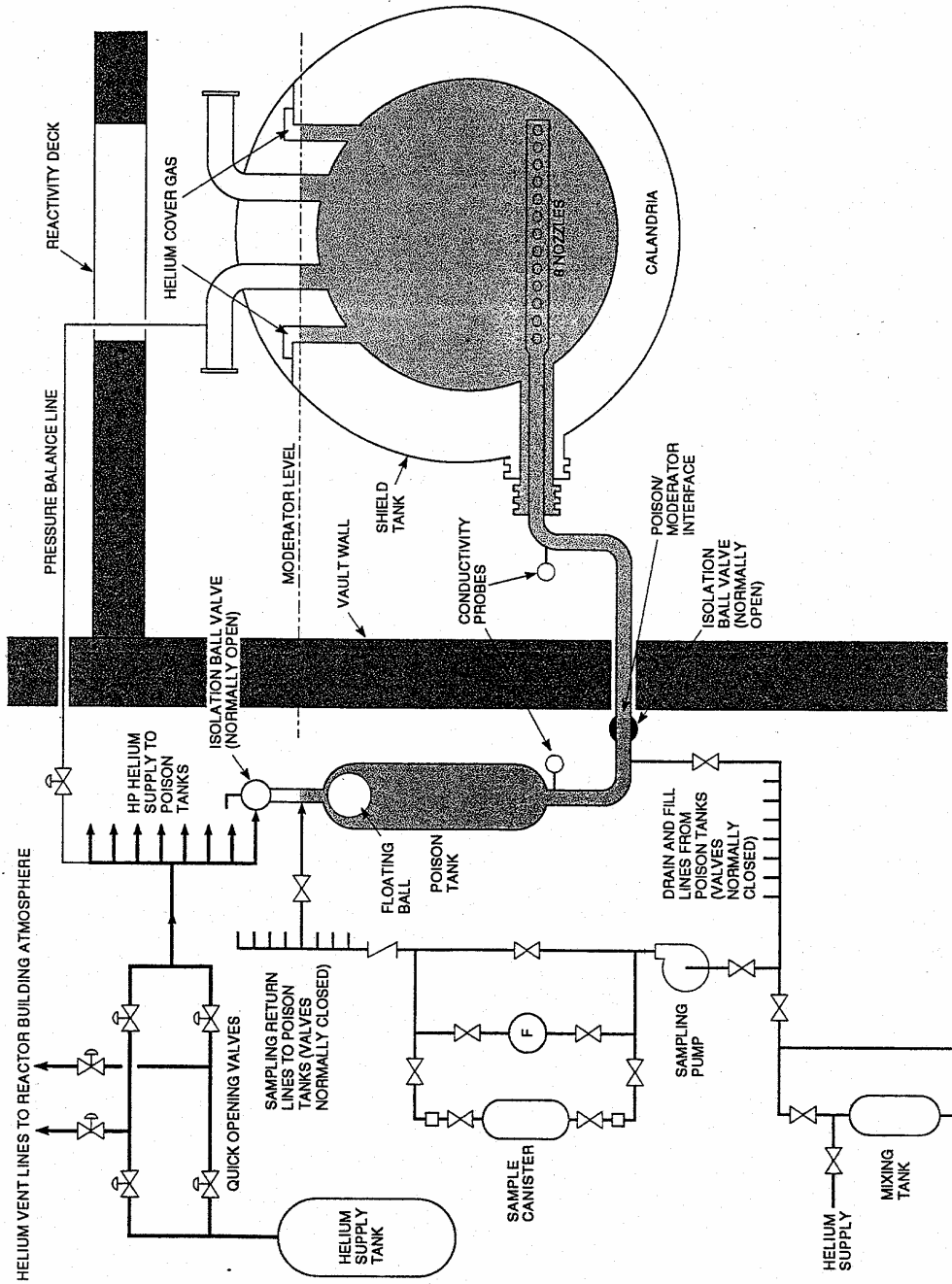

Figure 6.7. Shutdown System No. 2 Liquid Poison Injection System.

Each poison tank contains a floating polyethylene ball which sits at the top of the poison tank prior to injection to restrict the movement of poison upwards due to variations in moderator level. When an injection is initiated, the helium pressure transfers the poison to the calandria and the ball falls to the tank bottom. In the bottom position, the ball sits at the poison tank outlet and prevents the release of a high pressure helium to the calandria.

Each poison tank can be isolated by manual isolating valves located in the gas and poison legs to permit maintenance and testing on a poison tank without disabling the shutdown system. An interlock ensures that only one tank is out of service at any time. Alarms in the Main Control Room and Secondary Control Area warn the operator if valve closure occurs on more than one poison tank.

Measurements are made of helium makeup supply pressure, helium supply tank pressure, injection tank level, and injection tank ball position. Deviation from specified limits by any measurement initiates an alarm in the main control room. Limit switches are provided on each of the quick-opening valves, vent valves and helium makeup valve at the closed and opened positions. The poison solution is prepared in a mixing tank from which it is transported under moderate pressure to the poison tanks. After firing and flushing, the diluted poison solution is drained from the poison tank to the mixing tank where its concentration is restored. The mixing tank may also be used for sampling.

Equipment Layout

The quick-opening valves and poison tanks are located outside the reactor vault, where they are accessible during reactor operation. The poison tanks are situated at the vault wall to minimize injection time.

The ball valves in the poison injection line are located outside the reactor vault for ease of maintenance and operation. The drain valves adjacent to these ball valves are used during draining and refilling of the poison tanks. The poison interface is at the poison line ball valve.

The ion chambers and the in-core detectors for shutdown system number 2 are horizontally mounted and their cables are routed separately from those of shutdown system number 1. The cubicles containing the trip computers and relay logic for each channel are located in the secondary control area.

A section of the safety systems panels and console in the main control room is allocated solely to shutdown system number 2. The shutdown system number 2 annunciation is on a vertical panel, while the trip test and channel select switches, video display units and the manual trip buttons for shutdown system number 2 are mounted on the console. These are connected to the shutdown system number 2 trip and test computers in the secondary control area by channelized fiber-optic data links.

Instrumentation and Power Supplies

All the information required on the tripping parameters and the status and operation of the system can be displayed on video display units in the main control room and the secondary control area, at the operator's command.

Separately channeled Group 2, Class II power supplies are connected to each of the shutdown system number 2 channels. Fuse failure or loss of power to a channel results in a channel trip, and is annunciated. A loss of power to two or more channels results in a reactor trip.

Annunciation for shutdown system number 2 is provided in the secondary control area and in the main control room (using buffered outputs from the secondary control area).

The shutdown system number 2 control room panel contains window equivalent alarms which indicate the state of trip parameters. When a parameter reaches the trip level, these windows show an alarm state.

The parameter and channel trip status are fed to the plant display system through a fiber-optic link for annunciation and event sequencing. During upset conditions, the time and the sequence of shutdown system number 2 parameters exceeding their limits may be printed out on demand.

Helium tank pressure, valve position, poison tank level, helium makeup supply pressure and poison front position are indicated in the main control room and secondary control area. The quick-opening valve limit switches are also used to monitor the valve stroking time during channel test.

Trip and Test Computers

Shutdown system number 2 has computerization of the trip logic, system testing and monitoring and display functions, as was seen in Figure 6.6.

Design Evaluation

Shutdown system number 2 introduces negative reactivity with sufficient speed to meet all reactor shutdown design requirements. The gadolinium poison continues to disperse throughout the moderator until sufficient negative reactivity in excess of 200 mk is achieved. The initial variation of this worth is shown in Figure 6.8 Static reactivity calculations are valid on the assumption that delayed neutrons are in equilibrium with the flux.

The initial reactivities are based on calculations of the effect of short poison jets in the moderator. Power rundown measurements at operating CANDU plants confirm the calculation methods used to determine the neutronic characteristics of the system.

Concentration of the poison in the injection tanks can decrease to half its normal value and still retain over 90 percent of shutdown system number 2 effectiveness.

The effectiveness of shutdown system number 2 is evaluated on the basis of one of the poison injection tanks not functioning, (i.e. assuming the most effective unit is unavailable).

The unavailability of shutdown system number 2 is required to be 1×10^{-3} years per year or less, assuming only one poison injection line is unavailable.

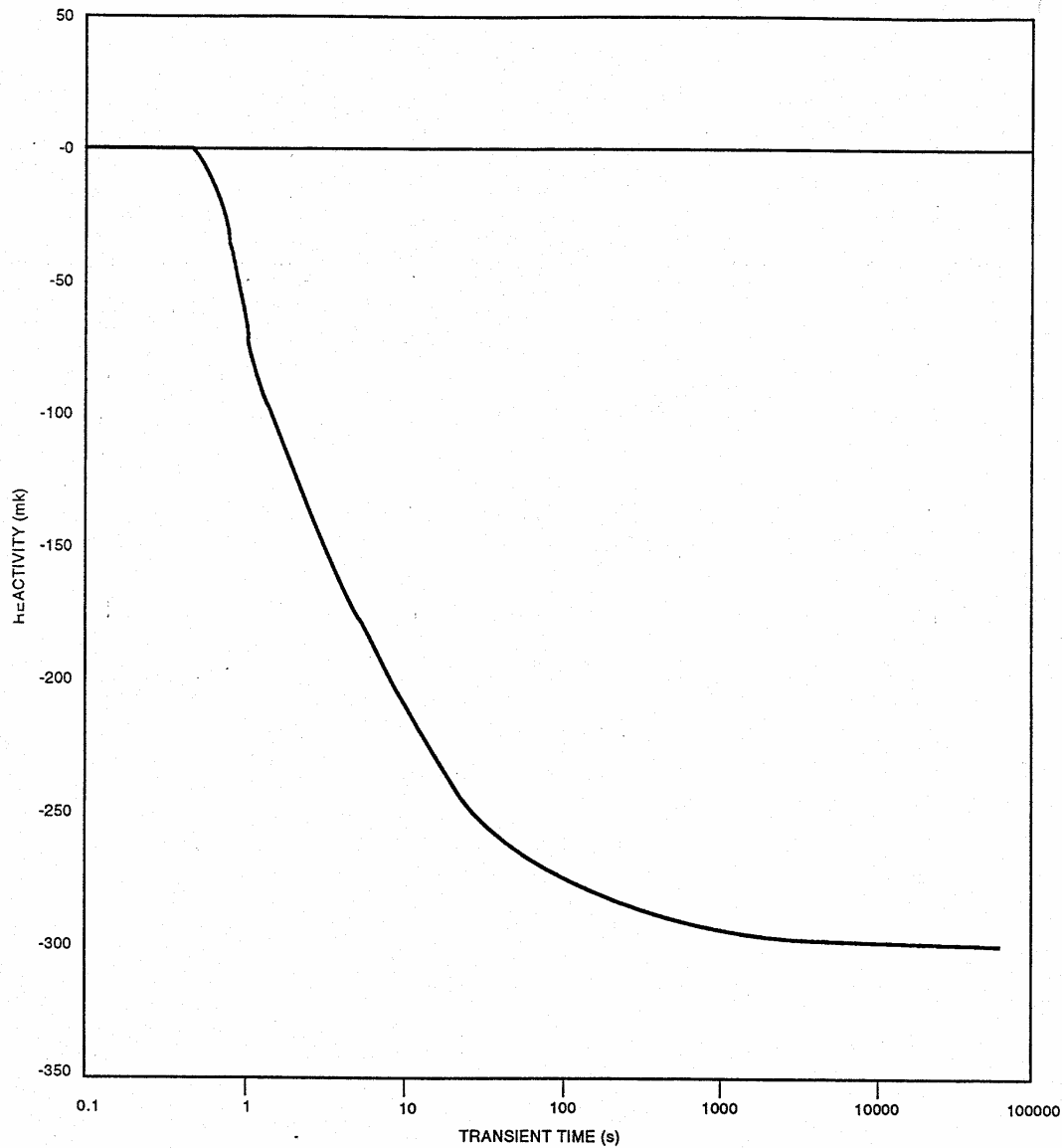

940180-2.9.2-6

Figure 6.8. Shutdown System No. 2 Negative Reactivity Insertion Rate.

Operation

Interlocks are provided as follows for interface with other systems:

The tripped condition or unavailability of shutdown system number 2 (more than one tank out of service or helium tank pressure low) prevents moderator poison removal and also adjuster, shutdown rod and mechanical control absorber withdrawal. The D₂O supply to the moderator is also isolated.

As a normal condition, all channels (three) of each trip parameter are available and clear. Each channel is periodically tested. Unavailable channels (i.e., unsafely failed) are placed in a safe (tripped) condition immediately and kept in that state until the repair is completed.

The shutdown system number 2 test logic prevents the testing of two channels in succession within a specified time period to prevent spurious trips. The reactor may not be operated at power if shutdown system number 2 is not available.

6.4 EMERGENCY CORE COOLING SYSTEM

The emergency core cooling system is designed in compliance with the Canadian Regulatory Requirements as described in the following sections.

Cooling Requirements

The system maintains or re-establishes cooling of the fuel and fuel channels for specified loss-of-coolant accidents so as to limit the release of fission products from the fuel and maintain fuel channel integrity.

The fuel in the reactor and the fuel channels are kept in a configuration such that continued removal of decay heat produced by the fuel can be maintained by the emergency core cooling system for as long as it is required to prevent further fuel damage.

For small loss-of-coolant accident events, the emergency core cooling system prevents any failure of the fuel in the reactor due to lack of cooling. Where the initiating failure is in a fuel channel, this requirement does not apply to that channel.

After reestablishing sufficient cooling of the fuel, the system is capable of providing sufficient cooling flow for a period of four months to prevent further damage to the fuel. This is accomplished by re-circulating the coolant mixture discharging from the accident location, back to the heat transport system.

Environmental Requirements

Emergency core cooling system equipment, required to operate or continue operating following exposure to severe environmental conditions following a loss-of-coolant, is environmentally qualified to withstand these conditions.

Unavailability Requirements

The system is designed to meet the unavailability on demand target of 1×10^{-3} for ECC initiation. Each component of the system and subsystems is monitored and/or periodically tested to demonstrate that this target is met. Valves located inside containment are accessible to permit testing and maintenance during normal reactor operation.

Long-term reliability targets are defined, and the design of the system takes into account the long term reliability of those components which must continue to function.

Redundancy is provided such that failure of any single active component in the system will not impair the system to the extent that it will not meet its minimum allowable performance requirements.

Seismic Requirements

All equipment and components in the system and subsystems needed to maintain cooling of the fuel 24 hours after a loss-of-coolant accident are designed to withstand at least an earthquake of site design earthquake intensity.

Tornado Requirements

A tornado is not postulated to cause a loss-of-coolant accident since the reactor building serves as a barrier to missiles. Also, based on probability, the coincident event of loss-of-coolant accident and tornado is considered incredible. Therefore, there is no requirement to qualify the emergency core cooling system for tornados. However, most of the emergency core cooling system is located within the reactor building, and therefore protected, while the high energy components located outside the reactor building (the gas tanks, recovery pumps, valves and piping) are tornado protected, consistent with site requirements.

Separation and Independence Requirements

The emergency core cooling system is physically and operationally independent from other special safety systems and from other Group 1 and Group 2 systems, except for those which are required to assist in the system operation.

The emergency core cooling system is designed so that pipe whip in adjacent systems will not impair operation.

System Description

The emergency core cooling system supplies coolant to the reactor headers in the event of a loss-of-coolant accident. Irrespective of the break size or location, the emergency coolant is directed to all reactor headers. Figure 6.9 shows a schematic diagram of the emergency core cooling system.

The system operation is divided into two stages; the injection stage and the recovery stage. The injection stage is provided by two high pressure gas tanks located outside the reactor building and connected via a valve station to the top of four water tanks located inside the reactor building. The water tank outlets are joined by a distribution header from which two separate lines symmetrically feed the reactor headers (two inlets and one outlet) at each end of the reactor.

During the injection stage, flow from the reserve water tank to the emergency core cooling system sumps is initiated and the emergency core cooling pumps, located outside the reactor building are started and the recovery stage begins. When flow from the reserve water tank stops, there is about 1.5 m of water on the reactor building floor.

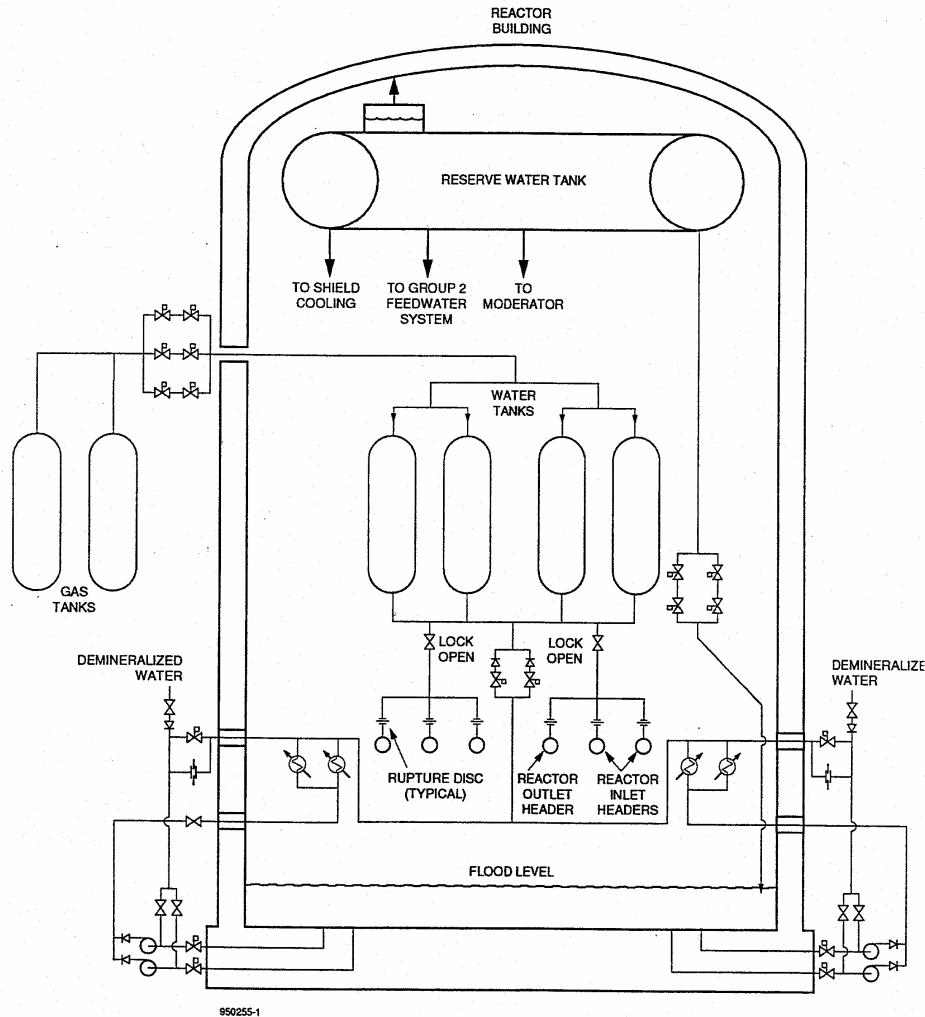

Figure 6.9. Emergency Core Cooling System.

In the recovery stage, the recovery pumps draw water from the fuelling machine vault floor, and discharge it into the reactor headers via the emergency core cooling heat exchangers. The recovery stage begins when the emergency core cooling system water tanks are depleted. The water subsequently escapes from the break in the heat transport system, falls to the floor and is re-circulated by the recovery pumps. The recovery stage provides a long term heat sink. The emergency core cooling pump motors are powered by Class IV and provided with backup power from the Group 2 Class III electrical systems.

Emergency core cooling is initiated when the heat transport system pressure drops to a predetermined value and either the high reactor building pressure, or a sustained low reactor outlet header pressure conditioning signal is activated.

Instrumentation and Control

The emergency core cooling system employs dedicated computers which perform data acquisition and automatic activation functions.

Each signal loop essential for the system operation is triplicated so that a single loop component or power supply failure does not incapacitate or spuriously invoke the operation of the system. This triplication approach involves isolation between loops of the three channels and the use of unique transmitter mounting racks, electrical cubicles, initiation computers and power supplies for each channel.

The logic used with the three channels is such that any two channels alarming in the heat transport pressure monitoring loops in conjunction with any two-out-of-three of the conditioning signal loop will generate the loss-of-coolant accident signal.

The controls and power supplies to each valve of a pair of valves are separated and independent. They are referred to as the 'odd' and 'even' circuits. All electrical valves required to operate to allow light water injection are supplied from Group 2, Class III power.

System Operation

The emergency core cooling system does not operate during normal reactor operation but remains fully poised to be activated on a loss-of-coolant accident signal.

Blowdown

Following a loss-of-coolant accident, the heat transport pressure drops at a rate dependent on the size of the break. The time from the loss-of-coolant accident until the heat transport pressure reaches the injection pressure is known as the blowdown period.

For larger size breaks, the blowdown period is short and fuel cooling may or may not be adequate during this period depending on the break size and location. For small breaks, the initial emergency core cooling injection pressure is such that fuel cooling is adequate during blowdown. Therefore, the purpose of injection is to restore cooling for large breaks, and maintain cooling for small breaks.

Emergency Core Cooling Initiation

The emergency core cooling system is initiated on a loss-of-coolant accident signal. To generate this signal, the heat transport system pressure has to fall to a predetermined value and one of the conditioning variables (high reactor building pressure or sustained low reactor outlet header pressure) has to be activated. The sustained low reactor outlet header pressure signal is used as a conditioning variable for detection of a small loss-of-coolant.

The high reactor building pressure signal provides coverage for all other loss-of-coolant accidents. The conditioning signals are provided to prevent spurious operation of the system.

The system logic performs the following functions:

- opens the gas isolation valves,
- opens the main steam safety valves,
- opens the isolation valves in the line connecting the reserve water tank to the F/M vault floor,
- starts the emergency core cooling recovery pumps, with a time delay,
- opens the emergency core cooling pump suction valves and starts the Group I and Group 2 Class III diesels,
- opens the recirculation line isolation valves (when high pressure injection is complete).

The rupture discs in the emergency core cooling system burst when the gas isolation valves open after the heat transport system pressure falls sufficiently below the high pressure emergency core coolant injection pressure.

The opening of the main steam safety valves on the loss-of-coolant signal provides a rapid cool-down of the steam generators, commonly referred to as steam generator crash cool-down. This reduces the transfer of heat from the secondary side to the primary side during the initial period of emergency core cooling injection and allows the steam generators to provide a long-term heat sink for "small" breaks during steady state emergency core cooling operation. Water to the steam generators is supplied by the feedwater system and is backed up by the Group 2 feedwater system. For scenarios involving a small loss-of-coolant accident and the loss of the emergency core cooling, a steam generator crash cool-down depressurizes the heat transport system and reduces the stress on pressure tubes.

During the full sequence of emergency core cooling operation, decay heat removal is by transfer of heat to the steam generators or by discharge of fluid through the break. The latter mode predominates for the large breaks; the former mode predominates for small breaks.

Injection Stage

Upon a loss-of-coolant accident signal, water from the emergency core cooling water tanks under pressure is directed via the reactor headers to the fuel channels to refill the core. Simultaneously, demineralized water is transferred by gravity from the reserve water tank to the emergency core cooling system sump.

While injection is underway, two of the emergency core cooling recovery pumps are started. If one pump fails to start (indicated by a low pump differential pressure), a standby pump starts automatically.

Recovery Stage

Recovery stage operation follows the injection stage. The mixture of the heat transport coolant and water from the reserve water tank collected on the floor of the reactor building is then returned to the heat transport system by the emergency core cooling recovery pumps. For large breaks, decay heat is removed from the core via the coolant discharged from the break and this heat is transfer-red to the Group 1 re-circulated cooling water, or the Group 2 raw service water as a backup, via the emergency core cooling heat exchanger. The containment air coolers, serviced by raw service water, also remove heat.

For small breaks, decay heat is transferred to the steam generators and rejected via the main steam safety valves. These valves have a total capacity of over 100 percent steam flow at normal steam generator pressure.

The steam generator feedwater supply after a loss of coolant is provided by the main feedwater pumps on Class IV power or by the diesel powered auxiliary feedwater pump, which draws water from the deaerator and the demineralized water storage tank. An alternative source of feedwater to the steam generators is the Group 2 feedwater system. The feedwater to the steam generators is required during the long-term emergency core cooling operation following a small break.

6.5 CONTAINMENT SYSTEM

The basic function of the containment system is to form a continuous pressure-confining envelope about the reactor core and the heat transport system in order to limit the release to the external environment of radioactive material resulting from an accident. An accident which causes a release of radioactive material to containment may or may not be accompanied by a rise in containment pressure.

To achieve this overall function, the containment system includes the following related safety functions:

- Isolation: to ensure closure of all openings in the containment when an accident occurs.
- Pressure/activity reduction: to control and assist in reducing the internal pressure and the inventory of free radioactive material released into containment by an accident.
- Hydrogen control: to limit concentrations of hydrogen/deuterium within containment after an accident to prevent potential detonation.
- Monitoring: to monitor conditions within containment and the status of containment equipment, before, during and after an accident.

In addition, the containment structure also serves the following functions:

- limits the release of radioactive materials from the reactor to the environment during normal operations,
- provides external shielding against radiation sources within containment during normal operations and after an accident,
- protects reactor systems against external events such as tornados, floods, etc.

Design Basis

The containment system is designed in compliance with Canadian Regulatory Requirements for Containment Systems. The design pressure for the containment is above the maximum building pressure resulting from any failure of the heat transport system (with or without credit for the emergency core cooling system), coupled with unavailability of the most effective active pressure reduction system. The containment is designed for an unavailability of not more than 1×10^{-3} years per year. The containment structure will not be damaged following any steam or feedwater line break.

The containment design leakage rate is 0.2 percent of the containment free volume per day at the design pressure.

Test facilities and procedures are provided to confirm that the containment system (including required safety support systems) operates satisfactorily when required and to demonstrate the reliability of the system.

The containment envelope, including the containment isolation devices, e.g., in the reactor building ventilation system, is seismically qualified for a design basis earthquake.

Control measures are included to limit hydrogen/deuterium content within any significant enclosed subvolume of containment following an accident.

System Description

The containment system includes a reinforced concrete containment structure (the reactor building) with a reinforced concrete dome and an internal steel liner, access airlocks, equipment hatch, building air coolers for pressure reduction, and a containment isolation system consisting of valves or dampers in the ventilation ducts and certain process lines penetrating the containment envelope.

Definition of Containment Envelope

a. Building Structure

All internal surfaces of the reactor building perimeter wall, dome and base slab are part of the containment boundary.

b. Piping and Ducts

All pipes or ducts which penetrate containment (except closed Class 1 or 2 systems which can be monitored for leaks) are provided with containment isolation valves or dampers. Lines which are open to the containment atmosphere during normal operation have two isolation valves in series which are automatically closed on a high containment pressure or high radioactivity signal. The containment boundary includes the pipe or duct from the containment structure inner surface up to and including the outer containment isolation valve. The main steam lines connect to the high pressure turbine via turbine stop valves, which can be used to isolate pairs of steam generators, if required, following a steam generator tube rupture. A check valve prevents blowback from a steam generator in the event of a failed feedwater line.

The irradiated fuel discharge duct and new fuel duct are part of containment during fuel transfer. When the fuelling machine is not attached, both ducts are sealed with a pair of containment isolation valves, in series.

The valves and lengths of pipe forming part of the containment boundary are designed in accordance with the design requirements for the containment boundary.

c. Airlocks and Hatch

The airlocks incorporate two sealed doors in series. The doors are interlocked so that only one can be open at any time. The containment boundary extends to the outer door of the airlocks and includes the equipment hatch.

Containment Components and Subsystems

The containment system comprises the following structures, components and subsystems:

- a. A reinforced concrete containment structure, with a leak tight steel liner covering the inside of the concrete perimeter wall, dome and base slab.
- b. Steel pipe and ducting form part of the containment boundary where they penetrate containment.
- c. Piping and cable penetrations, which provide an engineered seal at the point where piping, ducting and electric cables penetrate containment.
- d. Containment isolation - dual valves or dampers normally open on process penetrations are automatically closed on a two out of three signal indicating high containment pressure or high activity within containment.

Measurements of reactor building pressure and radioactivity are triplicated and channelized. A two-out-of-three indication of a containment isolation requirement on either variable initiates automatic closure of normally open containment isolation valves and dampers, together with other active containment measures, e.g., energizing the hydrogen igniters. The N, Q channels of N, P, Q channelization are used on portions of the system which are duplicated. In these areas, either of two operating valves provides containment isolation. The isolation setpoint for radioactivity is set at a value consistent with operational limitations and background activity levels. The radioactivity monitors are located upstream of the building air exhaust isolation valves.

- e. Airlock, auxiliary airlock and equipment hatch.
- f. Reactor building and vault air coolers: the air coolers are used to cool the reactor building atmosphere, condense released steam, and thereby reduce containment internal pressure following a failure of the primary or secondary cooling systems.

The air coolers also operate while the plant is operating to cool the building and maintain a suitable environment for personnel working within the reactor building.

By promoting steam condensation, the air coolers also act to remove soluble radioactive material (except noble gases) from the containment atmosphere and to sweep hydrogen out of the reactor and fuelling machine vaults following loss-of-coolant accident.

During normal operations, the fuelling machine vault cooling circuit is separate from the air coolers and dryers for the accessible part of the reactor building. During loss-of-coolant accident, blowout panels and dampers open to ensure that both sets of air coolers act to condense the released steam.

The design basis for the building air coolers is established by normal operational heat loads and post-accident heat removal requirements.

In addition to handling air flow under normal operational conditions, the fan motors for building air cooler operating on Class III power are also rated to handle continuously the steam/water/air mixture and the temperature existing at the design value of pressure under accident conditions.

- g. Hydrogen igniters: the hydrogen igniters, located in the feeder cabinets at the bottom of the steam generator enclosure, and in the upper part of the reactor building, ensure that hydrogen/deuterium releases are ignited at low concentrations, thus ensuring that concentrations sufficient for a detonation do not occur.

Copyright information for Chapter 6:

Figures on pages 6-11, 6-14, 6-16, 6-20, 6-22, 6-25 and 6-22 are from CANDU[®] 9 480/NU Technical Description, AECL document 69-01371-TED-001 Rev. 1, January 1995. Reprinted with permission of Atomic Energy of Canada Limited (AECL).